

THE ORCHID ALBUM.

B/7.20

Herb. Acad.
C.H.
06169
1891
V. 9

THE
ORCHID ALBUM,

COMPRISING

COLOURED FIGURES AND DESCRIPTIONS

OF

NEW, RARE, AND BEAUTIFUL

ORCHIDACEOUS PLANTS,

CONDUCTED BY

ROBERT WARNER, F.L.S., F.R.H.S.,

AUTHOR OF SELECT ORCHIDACEOUS PLANTS,

BENJAMIN SAMUEL WILLIAMS, F.L.S., F.R.H.S.,

AUTHOR OF THE ORCHID-GROWER'S MANUAL, ETC.

HENRY WILLIAMS, F.L.S., F.R.H.S.,

AND

WILLIAM HUGH GOWER, F.R.H.S.

THE COLOURED FIGURES BY JOHN NUGENT FITCH, F.L.S.

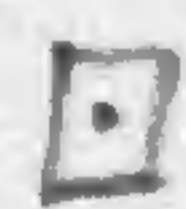

VOLUME IX.

Mo. Bot. Garden,

1894

LONDON:

PUBLISHED BY B. S. WILLIAMS & SON,

AT THE

VICTORIA AND PARADISE NURSERIES, UPPER HOLLOWAY, N.

MDCCCXCL

DEDICATED
BY SPECIAL PERMISSION

TO

H. R. H. The Princess of Wales,

BY

HER ROYAL HIGHNESS'

Very obedient and humble Servants,

ROBERT WARNER,

HENRY WILLIAMS.

INDEX TO PLATES.

	PLATE
BIFRENARIA AURANTIACA, <i>Lindley</i>	386
BRASSAVOLA GLAUCA, <i>Bateman</i>	415
CALANTHE MYLESII, <i>Williams</i>	402
CATTLEYA CRISPA DELICATISSIMA, <i>Williams</i>	424
CATTLEYA DOWIANA AUREA (<i>Young's var.</i>), <i>Williams</i>	432
CATTLEYA ELDORADO VIRGINALIS, <i>Williams</i>	388
CATTLEYA MASTERSONIÆ, <i>Rchb. f.</i>	385
CATTLEYA MAXIMA MARCHETT- IANA, <i>Williams</i>	404
CATTLEYA MOSSIÆ DECORA, <i>Williams</i>	421
CYMBIDIUM ELEGANS, <i>Lindley</i>	430
CYPRIPEDIUM ARTHURIANUM, <i>Rchb. f.</i>	389
CYPRIPEDIUM ASHBURTONIÆ SUPERBUM, <i>Williams</i>	400
CYPRIPEDIUM ELLIOTTIANUM, <i>Rchb. f.</i>	397
CYPRIPEDIUM LOWII, <i>Lindley</i>	428
CYPRIPEDIUM MACROPTERUM, <i>Rchb. f.</i>	391
CYPRIPEDIUM MARSHALLIANUM, <i>Rchb. f.</i>	418
CYPRIPEDIUM CENANTHUM SU- PERBUM, <i>Veitch</i>	420
CYPRIPEDIUM PORPHYROCHLAMIS, <i>Rchb. f.</i>	426
DENDROBIUM ALBUM, <i>Wight</i>	407
DENDROBIUM BRYMERIANUM, <i>Rchb. f.</i>	398
DENDROBIUM CHRYSOTIS, <i>Rchb. f.</i>	419
DENDROBIUM SCHNEIDERIANUM, <i>Rchb. f.</i>	411
DENDROBIUM TRANSPARENS, <i>Wallich</i>	396

	PLATE
DIPODIUM PALUDOSUM, <i>Rchb. f.</i>	422
DISA GRAMINIFOLIA, <i>Banks</i>	399
LÆLIA DORMANIANA, <i>Rchb. f.</i>	401
LÆLIA ELEGANS BLENHEIMENSE, <i>Williams</i>	393
LÆLIA ELEGANS BROOMEANA, <i>O'Brien</i>	413
LÆLIA MONOPHYLLA, <i>N. E. Brown</i>	395
LYCASTE GIGANTEA, <i>Lindley</i>	408
MASDEVALLIA MACRURA, <i>Rchb. f.</i>	431
MILTONIA BLEUANA SPLENDENS, <i>Bleu.</i>	412
ODONTOGLOSSUM ALEXANDRÆ OUTRAMII, <i>Williams</i>	403
ODONTOGLOSSUM ALEXANDRÆ WILSONII, <i>Williams</i>	387
ODONTOGLOSSUM ALEXANDRÆ PLUMATUM, <i>Williams</i>	414
ODONTOGLOSSUM CUSPIDATUM XANTHOGLOSSUM, <i>Rchb. f.</i>	390
ODONTOGLOSSUM GALEOTTIANUM, <i>A. Richard</i>	423
ODONTOGLOSSUM HASTILABIUM, <i>Lindley</i>	425
ODONTOGLOSSUM MULUS HOL- FORDIANUM, <i>Rchb. f.</i>	429
ODONTOGLOSSUM URO-SKINNERI, <i>Lindley</i>	417
ODONTOGLOSSUM YOUNGII, <i>Gower</i>	406
ONCIDIUM ANTHROCRENE, <i>Rchb. f.</i>	392
ONCIDIUM LARKINIANUM, <i>Gower</i>	405
PESCATOREA CERINA, <i>Rchb. f.</i>	394
PHALÆNOPSIS INTERMEDIA BRY- MERIANA, <i>Rchb. f.</i>	416
VANDA TERES CANDIDA, <i>Rchb. f.</i>	409
ZYGOPETALUM CRINITUM CÆRULEUM, <i>Hort.</i>	410
ZYGOPETALUM MACKAYI, <i>Hooker</i>	427

INDEX TO NOTES AND SYNONYMS.

UNDER PLATE	UNDER PLATE
<p>Awards made by the Orchid Committee of the Royal Horticultural Society for the first quarter of the year 1891 . . . 426 & 427</p> <p><i>Bletia glauca</i>, <i>Rehb. f.</i> 416</p> <p>Calanthe, a wonderful 425</p> <p><i>Cattleya Eldorado virginalis</i> 391</p> <p><i>Cattleya Trianae Hardyana</i> 427</p> <p><i>Cattleya Trianae plumosa</i> 426</p> <p><i>Cattleya virginalis</i>, <i>Linden and André.</i> . . 388</p> <p><i>Cattleya Wallisii</i>, <i>Hort.</i> 388</p> <p>Chamaeleons as Fly-catchers 410</p> <p><i>Cypripedium Creon</i> 426</p> <p><i>Cypripedium cruciforme</i>, <i>Zolling</i> . . . 428</p> <p><i>Cypripediums</i> at Streatham 423</p> <p><i>Dendrobium aqueum</i>, <i>Lindley</i> 407</p> <p><i>Dendrobium histrionicum</i> 398</p> <p><i>Dendrobium Hookerianum</i>, <i>Lindley</i> . . . 419</p> <p><i>Epidendrum maximum</i> 404</p> <p><i>Graumatophyllum paludosum</i>, <i>Griffith</i> . . 422</p> <p><i>Huntleya cerina</i>, <i>Lindley</i> 394</p>	<p><i>Laelia crispa delicatissima</i>, <i>Hort.</i> . . . 424</p> <p><i>Laelia glauca</i>, <i>Bentham and Hooker</i> . . . 416</p> <p><i>Lycaste Skinnerii alba</i>, Giant form of . . 428</p> <p><i>Maxillaria Heynderycxii</i>, <i>Morren</i> . . . 408</p> <p><i>Miltonia Bleui</i>, <i>Godefroy</i> 412</p> <p><i>Miltonia Bleuana</i>, <i>Linden and Rodigas</i> . . 412</p> <p><i>Milioniopsis Bleui</i>, <i>Godefroy</i> 412</p> <p>Obituary Notice, Mr. Benjamin Samuel Williams, F.L.S., F.R.H.S., (Frontispiece)</p> <p><i>Octadesmia monophylla</i>, <i>Bentham</i> . . . 395</p> <p><i>Odontoglossum luteo-purpureum</i> var. Amesianum 427</p> <p>Orchids at Mr. Lea's, Worcester 393</p> <p>Orchids at Mr. Reginald Young's, Liverpool 396</p> <p>Royal Horticultural Society's Exhibition in the Temple Gardens 429 & 430</p> <p><i>Trigonidium monophyllum</i>, <i>Grisebach</i> . . 395</p> <p><i>Vanda teres alba</i>, <i>Hort.</i> 409</p> <p><i>Wailesia paludosa</i>, <i>Rehb. f.</i> 422</p> <p><i>Zygopetalum cerinum</i>, <i>Rehb. f.</i> 394</p>

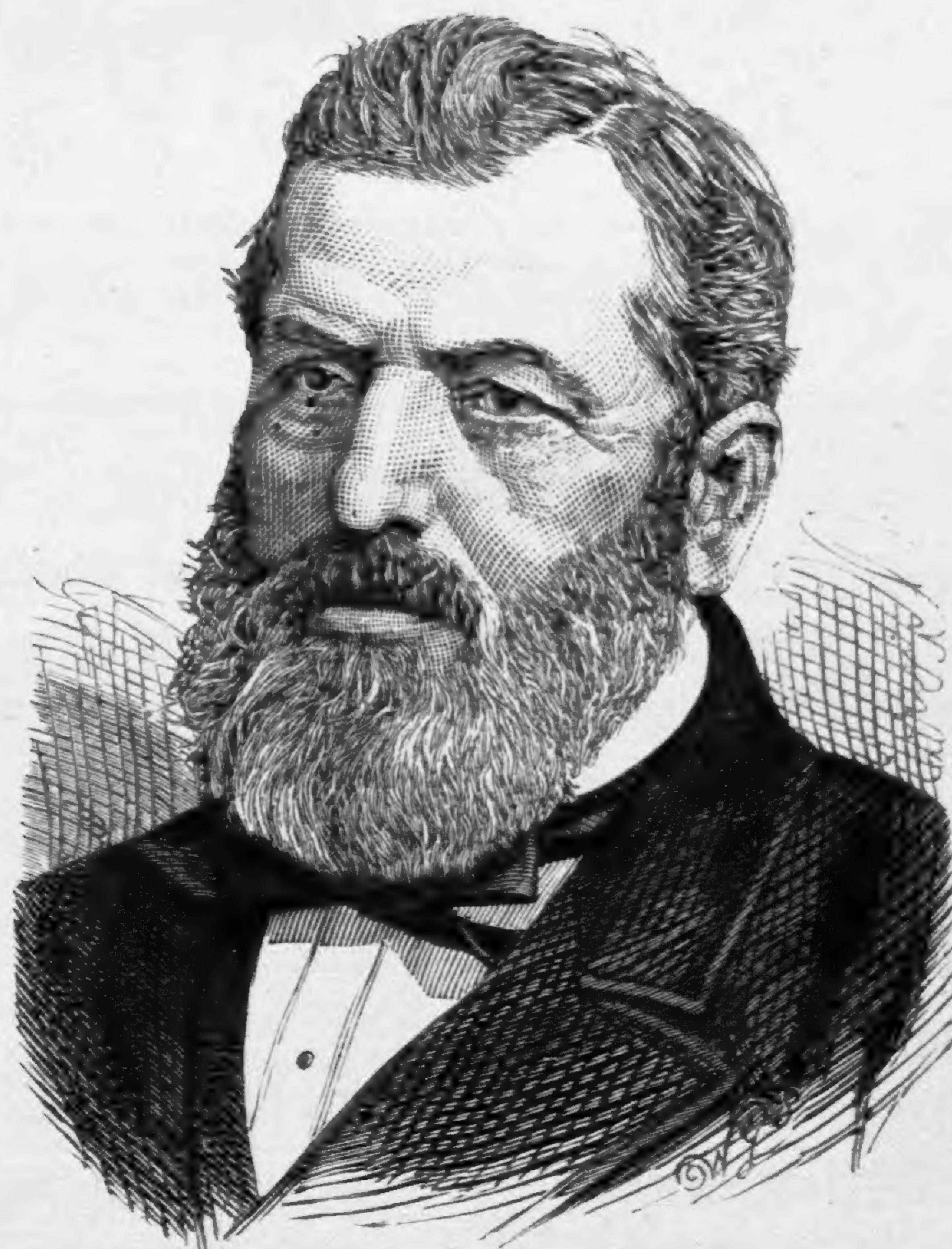

THE LATE MR. BENJAMIN SAMUEL WILLIAMS, F.L.S., F.R.H.S.

Born March 2nd, 1822.

Died June 24th, 1890.

Obituary.

IT is with mingled feelings of sorrow and regret that we have to announce the death of our beloved and venerated father, MR. BENJAMIN SAMUEL WILLIAMS, which took place on the evening of the 24th of June last, after a long and painful illness, which he bore with heroic patience and characteristic tranquillity. Perhaps the greatest sorrow befalls our venerable grandfather, who is still living, and who, from his extreme age, will doubtless feel the loss of his fourth son most acutely.

Mr. B. S. Williams was born at Hoddesdon, Herts, in 1822; his father, Mr. James Williams, being at that time gardener to John Warner, Esq., The Woodlands. At the age of fourteen Mr. B. S. Williams entered upon his first gardening appointment under his father at The Woodlands. His first love in floriculture was the Pansy, of which he became an ardent, enthusiastic, and successful exhibitor at the age of twenty, and of which flower he was to the last passionately fond. The next flower which attracted his attention, and to the cultivation of which he devoted much time, was the Ranunculus; from this he directed his mind to horticulture in general, and figured very prominently in the London suburban shows as a formidable rival in exhibiting fruits and vegetables. He afterwards sojourned for a short period of time in the nursery of Messrs. Adam Paul & Son, at Cheshunt, from whence he returned to The Woodlands, Hoddesdon, in the capacity of foreman to his father, under whose tuition he exerted himself with the greatest industry and assiduity, in order that he might master all the details of general gardening, and advance himself therein. He afterwards received the appointment of Orchid grower to C. B. Warner, Esq., who was then forming a large and extensive collection of these beautiful plants; he soon found full scope for his talents and energy in his new sphere, and began to lay for himself the foundation of the reputation, which he ever since nobly retained, of being one of the foremost and most successful Orchid cultivators of his day and generation.

It is worthy of note that one year he carried off all the first prizes for Orchids at the London shows, in competition with Mr. Hanbury, Mrs. Lawrence, and others, who owned the premier Orchid collections at that time.

His name will be handed down the vistas of time to future generations associated with Orchids—the Royal family of plants; to their study and cultivation the most important part of his active life was devoted with a zeal and enthusiasm that knew no bounds, because his whole soul was wrapt up therein. He excelled in this department on account of his wide and varied experience and extensive knowledge, and became a frequent exhibitor of these gorgeous flowers at the London Shows, and that, too, with marked success. He always maintained that single specimens made the best plants for exhibition purposes, and were far in advance of made-up plants.

The great event of his life was the foundation of the present business, which he commenced in partnership with Mr. Robert Parker, in the Seven Sisters Road, Holloway, in 1854, and continued until the year 1861, when the partnership was dissolved by mutual consent; Mr. Parker establishing himself at Tooting, and devoting his attention to the cultivation of hardy plants. Mr. Williams then removed to the premises where the business is now conducted, at Upper Holloway, where we were recently taken into partnership with him. The success which he achieved here is well known, and through his indomitable energy and perseverance the firm enjoys a world-wide reputation for the excellence of their plants and seeds. He was a continuous exhibitor of Orchids and other plants at all the principal London, Manchester, and other provincial shows, as well as at all the most important shows on the Continent and in America, in every instance honourably maintaining his reputation, and coming off with *eclat*.

In 1851, at the suggestion of Dr. Lindley, he wrote a series of articles for the *Gardeners' Chronicle*, entitled "Orchids for the Million." These articles were re-published in an amplified form in the first edition of the *Orchid Growers' Manual*, a work which has since passed through six editions; the last of which has been entirely remodelled and revised, and is now considered the standard work on Orchids, besides being the most complete work on the subject ever published. In addition to this, he published his work on *Choice Stove and Greenhouse Plants*, in two volumes, also a work on *Select Ferns*, all of which have passed through several editions, and have found a ready sale, which is steadily increasing. In addition to this, he wrote the cultural notes for *Select Orchidaceous Plants* of Mr. Robert Warner, which was commenced in 1862, and is still unfinished.

In 1881 he commenced his *magnum opus*—the ORCHID ALBUM—which was projected with the idea of supplying a demand for illustrations of Orchidaceous plants, with botanical descriptions of the plants figured, notes on their cultivation, and such general observations concerning them as might be likely to prove of interest or utility to Orchid growers. The work was dedicated by special permission to H.R.H. The Princess of Wales. Its appearance was hailed with great satisfaction in horticultural circles throughout the world, and it numbers amongst its subscribers nearly all lovers of Orchids and many of our leading and most

influential horticulturists. It has been carried on through eight volumes, and the firm intend to continue the work until it is completed. We hope that future volumes of the ORCHID ALBUM will be found none the less worthy because of the change in its editorial management, which this sad event necessitates.

The late Mr. B. S. Williams was interred at Highgate Cemetery on the 30th of June, amidst his bereaved family and a host of sorrowing friends, surrounded both by his present and many of his old employés, who deeply mourn his loss, for he was respected and revered by all who knew him.

The business at the Victoria and Paradise Nurseries will in future be conducted by us, his son and surviving partner, under the title of B. S. Williams & Son; and we hope to secure in the future the patronage which was so generously accorded to us in the past by our numerous friends and customers. No pains will be spared on our part to merit this, and it shall ever be our constant endeavour to maintain the high reputation to which the firm has attained.—H. WILLIAMS.

We are indebted to the Proprietors of the GARDENERS' MAGAZINE for the loan of the annexed Portrait.



J. Nees del.

CATTLEYA MASTERSONIÆ.

B. S. Williams. Sculp.

CATTLEYA MASTERSONIÆ.

[PLATE 385.]

Garden Hybrid.

Epiphytal. *Pseudobulbs* erect, clavate, thickening upwards, furrowed, from six to eight inches high, and diphyllous. *Leaves* broadly oblong obtuse, emarginate, leathery in texture, and deep green. *Scape* terminal, erect, bearing several flowers, which are from four to five inches across. *Sepals* and *petals* soft rosy purple, the latter much the broader, and undulated; *lip* three-lobed, lateral lobes yellowish white on the outside, bordered with amethyst, anterior lobe broad and spreading, bifid, intense rich purple in front, the base and throat being of a soft clear yellow. It is the result of a cross between *C. Loddigesii* and *C. labiata*.

CATTLEYA MASTERSONIÆ, *Reichenbach fl.*, *Gardeners' Chronicle*, x., 1878, p. 556; *Williams, Orchid-Grower's Manual*, 6 ed., p. 189.

We here introduce to our readers one of the most charming of the hybrid Cattleyas raised by the Messrs. Veitch in their nursery at Chelsea, and we believe it to be one of the first seedlings produced in that establishment. There are numerous other hybrid kinds most beautiful in figuration, whose portraits will be found in the various volumes of this work, and there yet remains many others to be figured. The plant we here portray is the offspring of *Cattleya Loddigesii* and *C. labiata*, two species very different in growth and flower. The bloom of this plant partakes of the character of *C. labiata*, especially in its form and colours, whilst its growth with its two leaves more closely resembles the first-named parent. There are, however, great variations in seedling Orchids, and in *C. Mastersoniæ* there are also varieties, some far inferior to that whose portrait we here represent.

The specimen our drawing was taken from was grown by Mr. Woolford when he had charge of the late very fine collection formed by W. Lee, Esq., of Downside, Leatherhead, and at the sale of these plants it realised a considerable sum of money, as the variety is still very rare, especially such a fine form as this was well known to be.

Cattleya Mastersoniæ is a beautiful evergreen plant. The pseudobulbs are some eight inches high, and bear on the summit a pair of stout leathery leaves, which are about four inches long by two inches in breadth, and lively green in colour. The scape is terminal, rises from a large sheath, and bears several flowers, which are arranged somewhat closely together; they are of good substance, and measure some five inches across. The sepals and petals are rose-purple or amethyst, whilst the lateral lobe of the lip is yellowish white, with a delicate amethyst border, the front lobe being of an intense rich purple. It blooms during the spring months, and continues in beauty between three and four weeks.

This is a free-growing plant, which thrives in an admirable manner if its requirements are properly administered to; this is an important factor in the cultivation of all subjects. If it be found that a particular plant does not succeed under one mode of treatment, another system should be tried until success is attained; but care should be taken to give each trial sufficient time to be thoroughly tested, for plants do not at once spring rapidly from one state to another, but require attention and watchful care to restore them if in a bad condition. It is well to procure a healthy subject to start with, if possible; but sometimes one becomes possessed of a plant which sadly lacks vigour, and we have found from experience that unhealthy *Cattleyas* are frequently very difficult to restore to a flourishing condition. They require careful attention in the matter of heat and moisture, and situation we have found to be of the greatest importance. For instance, when a *Cattleya* has become shrivelled and unhealthy, we have found it a good plan to place it in a shady position, where it may be supplied with moisture about its stems and foliage; but this, again, requires thought, as much depends upon the season of the year. If the weather be hot, a slight syringing in the morning and afternoon will be highly beneficial, until the stems plump up and commence to root, when the plant or plants should be gradually inured to more light, care being exercised with regard to the moisture supplied, when it will recover vigour and health. When plants are in a sickly condition, they should never be allowed to bear any flowers—a process which exhausts them very much—and their energies will be better exerted in the production of new growth. Thus every plant in a collection should be under the watchful care of a responsible head, whose chief aim is to see that every plant is thriving, and upon the least sign to the contrary, at once set about its restoration. The plant will have been suffering some little time before its condition is noticeable, and will require immediate attention, as delays in such cases are often serious and dangerous.

We find the *Cattleya* in question succeeds either in a pot or hanging basket, but in both cases it must be kept near the roof-glass, in order to afford it as much light as possible. It should be potted in good fibrous peat, from which all the fine particles have been shaken, to which may be added a little chopped sphagnum moss, the object in chopping the latter being to allow of its mixing in a better manner with the peat fibre. In potting or basketing the plants, a few nodules of charcoal should be added from time to time, which allows the roots more freedom, and also assists in keeping the soil more sweet about them. The drainage must also be ample and thorough, as the roots require a fair amount of water during active growth; but it requires to be carried quickly away, and everything about them should be kept in a sweet and healthy condition.



BIERENARIA AURANTIACA

BIFRENARIA AURANTIACA.

[PLATE 386.]

Native of Brazil and Demerara.

Epiphytal. *Pseudobulbs* broadly ovate, compressed, monophyllous. *Leaves* oblong ovate, acute, plicate, tapering below into a short footstalk. *Scape* erect, springing from the base of the pseudobulb, some six or eight inches high, bearing several rich yellow flowers, which are somewhat obscurely spotted with orange. *Sepals* and *petals* oblong, spreading, and nearly uniform in size and shape, slightly undulate; *lip* three-lobed, clawed, articulated with the base of the column; lateral lobes oblong, deflexed, anterior lobe large, bifid, bearing a fleshy excrescence near the base. *Column* sub-cylindrical.

BIFRENARIA AURANTIACA, *Lindley, Botanical Register*, xxii., t. 1875; *Botanical Magazine*, t. 3597.

Bifrenaria aurantiaca belongs to one of the smallest genera of the Orchidaceæ, and its nearest ally is *Lycaste*; indeed, some of the species have been transferred to that genus. This plant is similar in growth to *Lycaste Harrisoniæ* (an old species that is far too little grown), and its flowers are produced upon short erect spikes in a similar manner. It is a showy species, as may be readily inferred by a glance at our present illustration, being also of easy culture. Although it has been an inhabitant of our gardens for upwards of fifty years, it deserves far more extended cultivation than is accorded it.

The specimen from which our figure was taken was grown in the fine collection which has been brought together by R. H. Measures, Esq., The Woodlands, Streatham, in whose garden it produced a grand effect, and we were pleased to obtain a figure for the ALBUM of such an old and good plant. The one in question was suspended at the end of a house at just the right level with the line of vision, and it presented a splendid appearance, with its bright yellow flowers and splendid large dark green foliage, in just such a position as to display its attractions to the best advantage.

Bifrenaria is a name given to some of the Maxillaria-like plants, which have two bridle-like attachments to their pollen-masses instead of four, and *B. aurantiaca* is one of them. It is an evergreen species, with rounded compressed pseudobulbs and dark green plaited leaves. The spike is produced from the side of the pseudobulbs near the base, and bears a raceme of several flowers, which individually are some three inches across and of a bright yellow colour. It blooms during the winter months after the growths are completed, and the flowers last a considerable time in full beauty.

The plant will thrive well on a block of wood or on a raft. This latter plan is a good system to cultivate the plant upon, as it enables the flowers to be seen to the best advantage; but being grown in this way it requires more attention in watering than when cultivated in a pot, which was the old-fashioned way in which we used to grow this species years ago. During the time of its active growth the block or rafts should be taken down and well soaked in a tub of water in order that a greater amount of moisture may be administered to the roots than can be given by syringing; but every day in summer, and even twice daily during the very hot weather, syringing overhead will be necessary. After growth is completed, and during the winter season, very little water is necessary, just sufficient to maintain the bulbs and leaves in a plump condition being all that is required, save the flowering plants, which, of course, require more, to enable them to properly develop their blossoms. Some living sphagnum moss must be kept about its roots, and it should be kept in a growing condition. If the moss should decay or become dead, remove it, and place some new and sweet material about the roots, as they cannot form strong and vigorous bulbs with any decayed moss or soil about them. The Cattleya house will be most congenial to its development, giving it all the light possible, save in the full sunshine, when a light shade is necessary to prevent the leaves from becoming disfigured.



1898

ODONTOGLOSSUM ALEXANDRÆ WILSONII

25/11/1898

ODONTOGLOSSUM ALEXANDRÆ WILSONII.

[PLATE 387.]

Native of Bogota, New Grenada.

Epiphytal. *Pseudobulbs* oblong-ovate, compressed, slightly marked with brownish purple, diphylous. *Leaves* oblong-ligulate, acute, channelled in front, and keeled behind near the base, deep green. *Scape* radical, raceme many-flowered. *Flowers* beautifully coloured; *sepals* oblong-lanceolate, white suffused with rose, spotted and blotched with chestnut-brown; *petals* ovate, undulated, white suffused with rose, and heavily spotted with chestnut-brown in the upper part; *lip* slightly shorter than that of the normal plant, ovate, toothed at the edge, white, spotted in front with chestnut-brown. *Column* club-shaped, chestnut-brown.

ODONTOGLOSSUM ALEXANDRÆ WILSONII, *supra*.

This very pretty variety of *Odontoglossum Alexandræ* was imported a few years ago among many others. It is really quite surprising how many splendid varieties are sent home by our collectors, who, if they were only aware what grand varieties were in their various consignments, would in all probability stipulate for a much better remuneration than is usually accorded them, for when these splendid forms open their blooms they realise a large sum of money, and it is on the chance of obtaining such that so many imported *O. Alexandræ* are purchased. It is very curious and strange that this species varies so much more than many others; *O. Pescatorei* for instance, which is a species we have known longer than it, has certainly produced a few varieties, of which the superb form known as *Veitchianum* is the best, and has wonderfully improved since the time when we figured it in Vol. ii., t. 68, yet, as before remarked, these variations are far less frequent and less beautiful than the forms of *Alexandræ*, which crop up out of every importation. The beautiful spotted variety here depicted was bloomed in the fine collection formed by A. Wilson, Esq., of Sheffield, who possesses many splendid species and varieties of this order of plants, and they are well grown and carefully tended by the gardener, Mr. Pidsley.

Odontoglossum Alexandræ Wilsonii, like all the rest of the variations of this species, is a compact evergreen variety, resembling the typical plant in its pseudobulbs and growth. The inflorescence is produced in a similar manner, but the flowers are very distinct; the sepals and petals are white flushed with rose, and heavily spotted and blotched with chestnut-brown, the lip also being spotted with the same colour. This plant thrives under the same treatment as that which suits the typical plant, that is to say, it should be grown in a pot, and the pot must

be well drained; the soil should consist of fibrous peat and sphagnum moss in about equal parts, and this should be pressed down firmly. Nearly all the *Odontoglossums* require a fair supply of water during active growth, but it should pass quickly away from the roots, and not be allowed to lie round about their roots and become stagnant. In the resting season, if they really have any season of active rest, the roots must be kept in a moist condition, for in their native country they are subject to heavy rains at this season, and at this time they bring forth their flowers and commence their new growth, and when the blooms are over and the rains cease they enter upon a cooler season, subjected to heavy dews. These plants when under cultivation are benefited by cow manure, and we apply it in a weak state diluted with water, pouring it beneath the stages in the evening; this we find helps them very much in the development of bulbs and leaves, and tends to give a colour to both. Another great factor necessary to produce sturdy plants, is full exposure to light. We have found that *Odontoglossums* like all the light it is possible for us to give them, but they do not like the strong sunshine; little, however, serves to make them more robust and ripens up the bulbs, and well-ripened bulbs flower better and withstand our dull winter months far better than miniature sappy growth. The house in which these plants are grown should be kept clean and smart, as this displays the full beauties of the plants, and they have a far better appearance than plants present when kept in a slovenly, ill-cleansed Orchid house.



CATYLLA ... DE VIRGINIA ...

CATTLEYA ELDORADO VIRGINALIS.

[PLATE 388.]

Native of the Rio Negro, Brazil.

Epiphytal. *Pseudobulbs* clustered, erect, clavate, bearing a single, oblong-ligulate leaf. *Scape* terminal, bearing several very fragrant flowers. *Sepals* and *petals* somewhat narrow, of the purest white; *lip* at the base rolled over the column, becoming tubular, the front lobe spreading, of the same pure white as the sepals and petals, the throat stained with rich orange-yellow.

CATTLEYA ELDORADO VIRGINALIS, *supra*.

CATTLEYA VIRGINALIS LINDEN ET ANDRE, *Illustration Horticole*, 3 s., t. 257.

CATTLEYA WALLISII, *Hort.*

The genus *Cattleya* comprises many beautiful species and varieties which may claim to be the finest and most showy Orchids which we have in cultivation at the present day, and amongst them *Cattleya Eldorado* occupies a prominent position; it varies considerably in the depth of colour which is developed by the flowers of different varieties, but all and any of them are well deserving of the attention of Orchid growers, on account of the compact habit of this species and its free-flowering qualities; an additional recommendation is that its flowers are produced at a time when few Orchids are in bloom, and that they are deliciously fragrant. The form we here represent is a chaste and charming variety, differing entirely from the typical plant; in fact these albino forms in the *Cattleyas* are all exquisitely beautiful, and although this is not a new variety, it is ever a welcome and elegant addition to a collection of these plants. Another form, *C. Eldorado splendens*, we have already figured in Vol. vii., t. 310, which form is a very highly coloured variety, and contrasts well with the albino form called *virginalis*, which we now lay before our readers; both these forms are still rare, but they crop up in a promiscuous manner amongst the importations which arrive in this country. The new and rare varieties which from time to time bloom out of every importation, causes one to wish to be in their native country during the blooming season, and secure the many choice and select forms which are to be found.

Cattleya Eldorado virginalis is a splendid evergreen variety, which resembles the species so closely in its growth that it cannot be distinguished until its flowers appear. The bulbs are about eight inches high, and bear a very thick and fleshy leaf; the flower is formed just before the growth is completed, and when the bulb is strong it opens from the sheath with four or five blossoms, each of which measures some six inches across. The sepals and petals are pure white; the lip and

column is of the same colour, saving a stain of bright orange in the throat, this same colour in the throat being a great improvement in all these white Cattleyas. In addition to the chasteness of its flowers it is gratefully perfumed, which renders it very welcome through the months of August and September, and it lasts three or four weeks in full perfection if the flowers are kept free from cold damp, but if this is not provided against they soon become spotted, which soon disfigures the bloom and they speedily decay. The cultivation of this plant is very easy, but it requires to be kept dormant through the winter months. We find it thrives well in baskets suspended near the roof-glass, and also equally well in pots placed on the side stages of the house, where they have the advantage of the glass at the sides, in addition to that on the roof. The pots or baskets should be of medium size, over-potting being the great failing of young beginners in Orchid culture, to whom these remarks are specially directed, although re-potting will be necessary as the plants increase in size. We find that the best peat and sphagnum moss are the most suitable materials for this plant, although we have often seen other materials used, but in most cases those who dabble in these materials have to return to the peat and moss to restore their plants to health; indeed, we have seen many plants quite spoilt through potting in an eccentric manner, for during the forty years we have had in the cultivation of Orchids, we have never had any occasion to alter our system of potting, and have never seen any good results accrue from the use of the so-called improved potting material. This Cattleya requires the warmest end of the Cattleya house to produce vigorous growth, and it also delights in a moderate amount of water during the growing season. After the flowering is past and the growths are well ripened up, the water supply must be considerably reduced, and the plant should be kept as quiet as possible, in order to check growth before the spring; the want of attention to this is the cause why Cattleyas that flower on the season's growth in the autumn so seldom continue to thrive, for if not kept dormant, the growth they make through the winter months does not ripen sufficiently to produce a flowering bulb the next season. The best time for re-potting is in the spring, just when the young roots and growth begin to appear, when, as the sun increases in power, a slight shading will be found necessary, in order to preserve the foliage from being disfigured, and to preserve it in good colour.



CYPRIPEDIUM ARTHURIANUM

CYPRIPEDIUM ARTHURIANUM.

[PLATE 389.]

Garden Hybrid.

Terrestrial. *Leaves* narrowly ligulate, three to four inches long, faintly tessellated with dark green upon a pale ground. *Scape* erect, flowers solitary, large and showy. *Dorsal sepal* yellowish green, upper portion wavy and pure white, the coloured portion marked with spotted veins of brownish crimson; inferior sepal much smaller, and paler in colour, sparingly spotted with brown; *petals* oblong-ligulate, deflexed, and slightly recurved, undulated on both edges, particularly the upper one, purplish green on the superior half, veined with deep crimson, the inferior half pale yellowish green, with dotted lines of crimson, the edges ciliate; *lip* calceiform, with a wide aperture, greenish yellow, veined and streaked with brown, and dotted with crimson on the interior. *Staminode* large, pale yellow, with green centre.

The result of a cross between *C. insigne* and *C. Fairrieanum*.

CYPRIPEDIUM ARTHURIANUM, *Reichenbach f.*, *Gardeners' Chronicle*, n.s. ii., 1874, p. 676; *Orchidophile*, 1887, p. 209, with plate; *Veitch's Manual of Orchidaceous Plants*, iv., pp. 77 and 78, with fig.; *Williams, Orchid-Grower's Manual*, 6 ed., p. 238.

We have already figured numerous species, varieties, and hybrid *Cypripediums* in the previous volumes of the ALBUM, but the one here depicted is thoroughly distinct from any that have already appeared, and this is a point which must be taken into consideration by hybridisers—there should be no countenance given to any hybrid unless it carries with it some point of distinction, and it is our aim to portray in the pages of the ALBUM the most beautiful and interesting forms of this deservedly popular genus of plants, which cannot fail to give satisfaction to all lovers of the Orchid family. The subject of our illustration is the result of a cross between *C. insigne* and *C. Fairrieanum*. It was raised by Messrs. J. Veitch & Sons, of Chelsea, and was dedicated in 1874 to the late Mr. Arthur Veitch by Professor Reichenbach; it is at the present time one of the most distinct amongst the numerous forms of this genus which are now to be found in our collections. This is still a rare plant, and these hybrids take time to increase sufficiently to insure an example for all our Orchid growers; they differ from the species which are found in their native countries by our collectors when they ruthlessly clear out every plant they can find, entirely clearing the species from the locality; such must have been the case with *C. Fairrieanum* many years ago, as it has never again been found to this day. *C. superbiens* is another kind which has only been imported once, which is remarkable, and we can but regret this, as it is the very best of the *barbatum* section. Our artist's portrait

of this plant was taken from a specimen in our own collection in the Victoria and Paradise Nurseries, Upper Holloway, where with us it blooms very freely every year.

Cypripedium Arthurianum is a distinct and beautiful hybrid. It is a dwarf-growing evergreen plant, with foliage some five inches long and an inch broad; the scape is about eight inches high, and single flowered, each blossom measuring about five inches across. The flowers have somewhat the general appearance of *C. insigne Maulei*, the dorsal sepal being of a pale yellowish green, veined and spotted with blackish crimson; the petals are also veined with deep crimson, deflexed and recurved, which is the peculiar character of *C. Fairrieanum*, its other parent; lip veined and mottled with brown on a pale greenish yellow ground. It blooms during the autumn months, and if the plant is kept in a warm house, where it has been growing, its blossoms remain in full beauty for upwards of six weeks.

This plant thrives well in the temperature of the *Cattleya* house well exposed to the light, and appears to be intermediate in its constitution, one of its parents being a cool-house plant, whilst the other requires the heat of the East India house, but the offspring thrives best in an intermediate situation. It will grow well in either a pot or basket, but we find pot culture the more congenial to its wants; it, however, requires careful potting, also judicious selection of the material used, and although it does inherit some of the peculiarities of *C. Fairrieanum*, it nevertheless also partakes of some of the vigour of its other parent, *C. insigne*. From experience we find that it requires ample drainage, which should be covered with some rough peat fibre, and the soil consist of good fibrous peat, leaf-mould, and nodules of charcoal; the plant must be firmly potted, and elevated on a cone-like mound above the pot's rim. This variety requires careful watering, as it does not like so great a quantity as some of the members of this genus, but yet its roots should never be allowed to become dry, and herein lies one of the peculiarities in its cultivation. These *Cypripediums*, having no thick fleshy pseudo-bulbs to support them, or to draw upon during a period of drought, require great attention as regards the supply of moisture to their roots at all seasons of the year.



GLOTTIDIOSUM CUSPIDATUM XANTHOGLOSSUM.

ODONTOGLOSSUM CUSPIDATUM XANTHO- GLOSSUM.

[PLATE 390.]

Native of U.S. of Colombia.

Epiphytal. *Pseudobulbs* broadly oval, compressed, slightly furrowed, and deep green, bearing on the summit a pair of lanceolate leaves, which are narrow, almost petiolate at the base, and obtuse at the apex. *Scape* erect, much longer than the leaves. *Raceme* nodding, many flowered. *Flowers* nearly four inches across, and very showy; *sepals* linear-lanceolate, acute, deep chestnut-brown, bordered and tipped with yellow, and also transversely barred with a few streaks of yellow; *petals* broader than the sepals, ovate, acute, waved at the edges, bright yellow, heavily spotted and blotched with deep chestnut; *lip* broadly ligulate, acuminate, waved at the edges, bright golden yellow in front, behind which is a large patch of deep chestnut; disc and crest white with a yellow border, which is dotted with chestnut. *Column* curved, toothed at the sides, white, dotted with chestnut.

ODONTOGLOSSUM CUSPIDATUM, *Reichenbach f.*, *Lindenia* iii., t. 99; *Reichenbach f.*, *Xenia Orchidacea*, ii., t. 184.

ODONTOGLOSSUM CUSPIDATUM XANTHOGLOSSUM, *Reichenbach f.*, *Gardeners' Chronicle*, N.S., 1881, xv., p. 428; *Williams, Orchid-Grower's Manual*, 6 ed., p. 438.

This rare and magnificent *Odontoglossum* is one of the very best of this section, of which there are so many importations, but very few have proved to be so fine as the one here illustrated. It belongs to the *O. luteo-purpureum* group, but it is very distinct from the typical plant, the forms sent home from time to time by various collectors requiring to become established before they flower and become recognised, for now we have such a vast quantity of these plants it becomes difficult to recognise them from the shape of the pseudobulb only. This species is a native of U.S. of Colombia, a country which appears to abound in *Orchidaceæ*, from whence such vast quantities have been sent, and are still being sent to Europe, and to this country in particular.

Our present subject is a very free-growing plant as well as an abundant bloomer, throwing out splendid spikes of bloom when the plant is in vigorous health. The present plate was prepared from a specimen which did exist in our own collection in the Victoria and Paradise Nurseries at Holloway, but this season this beautiful plant has passed into the rich and rare collection of the Comte de Germiny, Chateau de Gouville, France, where *Odontoglossums* are cultivated in great numbers, and with great skill. Although some few years ago it was stated that France

was too warm for the successful cultivation of *Odontoglossums*, the plants under the care of Mr. Vincent prove such not to be the case, as at Gouville these plants are in the finest possible condition.

Odontoglossum cuspidatum xanthoglossum is a splendid compact-growing evergreen plant, having pseudobulbs and leaves of a rich dark green hue; its spikes are thrown up after growth is completed, the raceme being many flowered, and drooping from the weight of its flowers, which are very brilliantly coloured. The blooms are large, and the sepals and petals are rich golden yellow, blotched and barred with chestnut-brown; the lip is somewhat pandurate, cuspidate, the edges waved and toothed, yellow, blotched with a large spot of reddish brown at the base. It is a very brilliant and showy variety, especially when mixed with the white flowers of such kinds as *O. Alexandræ*, *O. Pescatorei* and others, and when so grouped it is very effective. It blooms during the months of March and April, and lasts fully six weeks in perfection.

The requirements of this *Odontoglossum* are identical with others from the cool regions of U.S. of Colombia, and of which we have so frequently given details in these pages. One great feature to be observed in the cultivation of these plants is to keep them free from all insects, which, if not well searched for, will infest cool growing Orchids; however, they having a lower temperature and moister atmosphere than the warm house species, are not so liable to become infested with insects, but there is a small-shelled snail (*Helix alliaria*) which is introduced with the sphagnum moss, and small slugs which have the same origin, that acquire a rabid taste for the young spikes of bloom as they appear, and unless they are rigidly kept down will be a source of great annoyance by so destroying the blossoms. Full instructions for the destruction of insects and all pests which infest the Orchid plants may be found in the sixth edition of *Williams' Orchid-Growers' Manual*, p. 79, and if the details there recounted are carefully studied, and the requisite remedies adopted, there will be little fear of these insects becoming troublesome; but if the work is done in a careless and negligent manner they will soon become a source of regret and lamentation.



CYPRIPEDIUM MACROPTERUM.

CYPRIPEDIUM MACROPTERUM.

[PLATE 391.]

Garden Hybrid.

Terrestrial. *Leaves* elliptic-oblong, some nine inches in length, and almost two inches in breadth, handsomely tessellated with dark green upon a pale green ground. *Scape* erect, two or more flowered. *Dorsal sepal* ovate, fringed on the edge with short black hairs, light green, suffused with brown at the base, netted with deep green veins, and narrowly bordered with white; inferior sepal similarly coloured, but smaller; *petals* deflexed, slightly undulated, some three or four inches long, the apical portion much the broadest, and clear purplish violet, the basal part greenish yellow, freely spotted with blackish wart-like spots, which are more or less hairy; *lip* large and obtuse, pale violet-purple above, greenish yellow beneath. *Staminode* green in centre, surrounded with dull purple and bordered with white.

It is the result of a cross between *C. Lowii* and *C. superbiens*.

CYPRIPEDIUM MACROPTERUM, *Reichenbach f.*, *Gardeners' Chronicle*, N.S., xviii., p. 552. Id. xx., p. 294. *Veitch's Manual of Orchidaceous Plants*, iv., p. 90.

Cypripedium macropterum is without doubt one of the best hybrids that has been obtained by the skill of the hybridiser, and it is a plant that should be found in every collection of Orchidaceous plants, as there is no fear that this variety will ever be discarded whilst these plants are grown. We have now such a vast quantity of fine species, hybrids and varieties of *Cypripedes*, that it will become necessary to weed out the inferior kinds, yet this is a point which depends upon the taste of cultivators, many of whom are admirers of the curious as well as of the beautiful, so that there will nearly always be a demand for distinct curious forms, independent of beauty. These *Cypripediums* are very easily crossed and raised from seed, they are easily cultivated, are for the most part free bloomers, and their flowers last a very long time in full beauty, and anyone having a fair amount of species and varieties may have a bloom for every day in the year.

This beautiful plant was obtained by Mr. Seden, in the establishment of Messrs. J. Veitch & Sons, of Chelsea, its parents being *C. Lowii* and *C. superbiens*, and the Messrs. Veitch say of it, "It is one of the comparatively few hybrid *Cypripediums* in which the characteristics of the seed parent predominate in the flower."

The drawing for this plate was taken by our artist from a plant which flowered in our own collection, in the Victoria and Paradise Nurseries, Upper Holloway, during the present summer.

Cypripedium macropterum is a compact and charming hybrid, with persistent, variegated foliage. The scape is terminal and erect, bearing two or more flowers, which

when expanded measure some six inches across; dorsal sepal pale green, veined with green of a deeper hue which passes into brownish at the base; petals three inches long, spirally twisted, yellowish towards the base, spotted with dark purple, becoming wholly pale purple towards the tips; lip dull brown. It blooms during the months of June and July, and continues several weeks in full beauty.

The details of *Cypripedium* culture have been so often given in the different volumes of the ALBUM, that it is not requisite to recapitulate in this instance; suffice it to say that drainage is of the utmost importance, and upon no account allow anything of a dead or decaying nature to remain about the plants, as this is very detrimental to their well being. Care must also be taken not to leave any of the roots exposed which have previously been covered, as sudden exposure to the air we have found to be injurious; those roots, however, which grow naturally on the outside do not suffer in any way from the exposure.

CATTLEYA ELDORADO VIRGINALIS, Plate 388.—We should have mentioned that this plate was taken from a fine plant in the collection of Reginald Young, Esq., Fringilla, Linnet Lane, Liverpool.



ONCIDIUM ANTHROCRENE.

ONCIDIUM ANTHROCRENE.

[PLATE 392.]

Native of New Grenada.

Epiphytal. *Pseudobulbs* four inches or more high, oblong, compressed, much furrowed, deep green. *Leaves* in pairs from the apex of the pseudobulbs, oblong-acute, carinate beneath, some six or eight inches long, and one-and-a-half inches wide, very dark green. *Scape* erect, sometimes branched, many-flowered. *Flowers* large and showy, measuring from two-and-a-half to three inches across; *sepals* and *petals* oblong-lanceolate, acute, nearly equal, much undulated, reflexed at the tips, ground colour greenish yellow, heavily marked with transverse streaks of deep brown; *lip* three-lobed, lateral lobes small, obtuse, yellow with numerous spots and dots of brown; anterior lobe somewhat ovate, cuspidate, undulated, white with a broad spot of brown at the base in front of the crest.

ONCIDIUM ANTHROCRENE, *Reichenbach f.*, in *Linnaea*, 1877, xli., p. 102; *Williams, Orchid Grower's Manual*, 6 ed., p. 474.

Oncidium is a very large genus, and it contains many small-flowered plants which have no claims to a position in the ALBUM; but it is a very great pity that the Refugium, which was so ably conducted by the late William Wilson Saunders, of Reigate, should not be continued for such species. On the other hand, however, this genus contains many large-flowered and showy kinds, which rank amongst the most beautiful of Orchids, and many of these charming kinds have appeared in former volumes of this work, whilst many more are waiting to appear. These showy kinds are among the most decorative plants in our Orchid houses, and by a selection of kinds, some may be had in flower during the whole year. They are for the most part easily grown, and flower freely annually, but yet they require care and attention after their flowering season is past, this being one of the main points in the cultivation of Orchids, for if strong and vigorous growth be not obtained, flowers in due season cannot be expected. The species here introduced to our readers is a most distinct and attractive one, at the same time it is one not often seen, but it well deserves the attention of every one desirous of forming an interesting and diversified collection. It is these diversified groups of plants that attract the attention of non-cultivators of Orchids, their bright and wonderful combination of colours, their grotesque forms, and in many instances their powerful and grateful odour, giving rise to wonder and surprise to a far greater extent than the gorgeous display made by a house full of Cattleyas or Lælias, or Odontoglossums, or any other one genus, magnificent as these plants are. It requires an admixture of beautiful kinds nicely arranged and grouped to enlist the

sympathies of a stranger, and to make an Orchid grower. We are indebted to the kindness of W. L. Barclay, Esq., The Briars, Reigate, for the opportunity of laying this species before our readers, the drawing being taken from a very fine and well-grown specimen in his collection, which is under the care of Mr. Bailey.

Oncidium anthrocrene is a very distinct and curious evergreen species, of dwarf habit. Its pseudobulbs are some four inches high, bearing rich dark green leaves, six or more inches in length, and its branching racemes of flower appear after the growth is completed. The plant somewhat resembles *Miltonia Warscewiczii* in its general habit of growth, but its spike of bloom is much longer, and is much branched. The sepals and petals are chocolate-brown transversely barred with yellow, and prettily undulated, the column is also similarly marked, whilst the lip is white. It blooms during the months of January and February, and it continues in full beauty for several weeks.

The plant in question should be grown in a pot, and this must be well drained; the soil should consist of good fibrous upland peat, mixed with some chopped sphagnum moss, and some nodules of charcoal. The potting season should follow the flowering season in this case, as soon after blooming the plant begins to grow. If the plant does not require re-potting, it will be much benefited by top-dressing, and this is the very best time to perform the operation, as then the new roots receive the full benefit of the new soil, at the same time care must be exercised that the old living roots be not injured, as want of thought in this matter often results in weak growth for the season, and loss of flower at the proper time. It enjoys a somewhat liberal amount of moisture to its roots during the growing season, and as its blooms appear during the winter months there cannot be said to be any season of rest for this plant, although much less water will suffice than during active growth, therefore let it always have sufficient moisture to keep the bulbs and leaves in plump and fresh condition. The temperature of the *Cattleya* house is most suitable for this season. It enjoys an abundance of light, and therefore should be placed near the glass; but it requires to be shaded from the hottest sun. The flowers of this species last a very long time in full perfection, so long, sometimes, as to act detrimental to the health of the plants through exhaustion; this should be avoided, and the spike should be cut before it acts deleteriously upon it. When cut it may be placed in those little tubes of water which are now becoming common, and are most useful, as they can be inserted in the pot and still have the appearance of being upon the plant.



H. Williams del.

LÆLIA ELEGANS BLENHEIMENSE .

LÆLIA ELEGANS BLENHEIMENSE.

[PLATE 393.]

Native of Southern Brazil.

Epiphytal. *Stems* terete, slender, somewhat clavate, two feet or more high, bearing on the summit a pair of thick and leathery leaves; these are linear-oblong, ligulate, and bright green. *Scape* terminal, issuing from a small, oblong, compressed sheath, and bearing three or four large and showy flowers. *Sepals* oblong-lanceolate, tapering to a point, pale rosy purple, becoming deeper towards the margins; *petals* much broader than the sepals, waved at the edges, of an intense, deep rosy purple; *lip* three-lobed, side lobes rolled over the column, anterior lobe deep magenta-purple, veined with a deeper shade of the same colour; throat yellow.

LÆLIA ELEGANS BLENHEIMENSE, *supra*.

There have been, during the last few years, large importations of *Lælia elegans*, the various plants producing a great diversity of colour. It is a species which has been in cultivation upwards of forty years, and many fine varieties have from time to time appeared. This is doubtless brought about from the plant having been collected in many new localities. Indeed, it appears to be so widely spread in Southern Brazil, that it does not appear possible to accept the statement of its presumed hybrid origin. Hybrids do not usually grow in such quantities, neither are they so widely distributed. It is very curious also, how, as a rule, the white or light-flowered varieties are mostly spring and early summer bloomers, whilst the darker forms are more often produced during late summer and autumn, the colours varying from pure white to rose, and even to the richest and deepest magenta and crimson; but it is only within the last few years that we have had so many of the dark-flowered varieties. Collectors have been fortunate enough to largely increase our stores of late, and they, being free growers and profuse bloomers, have proved a decided acquisition.

The one whose portrait we here lay before our readers is a charming variety. It first flowered at Blenheim, the seat of His Grace the Duke of Marlborough, after which it derives its varietal name. Our drawing was taken in the collection of Orchids which are gathered together at this place, which is a very large one; the vigour of the plants one and all testifying to the skill and energy of Mr. Whillans, who has charge of this fine establishment.

Lælia elegans Blenheimense is a magnificent variety, with fine evergreen foliage. It has slender, terete stems some two feet high, bearing on the summit a pair of linear, oblong, coriaceous leaves. The flowers proceed from a small sheath situated between the leaves; these are well formed and of good substance, and measure

individually five inches across; the sepals are of a pale rosy purple, becoming deeper in colour towards the edge; petals intense rose-purple; lip three-lobed, anterior lobe deep magenta-purple, veined with a deeper shade of the same colour; throat yellow. The flowers of this variety appear at a most unusual time for a dark variety; that is, in the month of February, and they continue in perfection for three weeks or a month.

We find from experience that this section of *Lælia elegans* requires a warmer and closer atmosphere than most of its congeners, by which means their stems are not allowed to shrivel; indeed, they require to be kept in a shady place, and their stems and foliage kept moist, until they plump up and form new roots. These plants require great attention, and should never be allowed to flower until they have become well rooted, and are thoroughly established. We cultivate the plants belonging to this section of *Lælia* by themselves, using one side of the house for them, a position in which they have full exposure to the light, but are shaded from the hottest sunshine. Here we give them an abundant supply of moisture between the pots and on the table, in order to produce a moist atmosphere during the season of growth, but in the winter months this is considerably reduced, as we give them only just sufficient to keep their bulbs in a plump and healthy condition. The pots must be well and thoroughly drained, the best material to use about their roots is good fibrous upland peat, and this should be made firm. They thrive equally well in either pots or baskets, and may be hung up near to the roof-glass; but there is one thing to avoid in this situation—it frequently becomes a very chilly place in winter, and therefore we would avoid too close a proximity to the glass during extreme cold weather.

ORCHIDS AT MR. C. W. LEA'S, PARKFIELD, HALLOW, WORCESTER.—There is at the present time (middle of November) a magnificent form of *Lælia præstans* in flower in this choice collection of plants, far surpassing anything we have hitherto met with. The individual flowers of this variety measure five inches across, the petals being two and a-half inches long by one inch and three-quarters broad. They are of a deep rosy purple; lip very large and full, well opened, intense magenta-purple on the front part, with a white throat. The rare *Cattleya Hardyana* was also flowering at the same time. Mr. Lea was also kind enough to send us some excellent photographs of some of the most notable Orchids which have recently bloomed with him, the most noteworthy being that of a grand plant of *Saccolabium cæleste*, having eleven spikes expanded of its lovely cœrulean blue flowers. This alone is a sight never to be forgotten, and it does the Orchid manager, Mr. Catt, the greatest credit for the admirable manner in which he has grown this plant.—B. S. W.



W. J. G. & Co. Lond. & N. York.

PES DATORPHA CERINA.

B. S. Williams. Publ.

PESCATORIA CERINA.

[PLATE 394.]

Native of Central America.

Epiphytal. Growth tufted, quite destitute of pseudobulbs, but bearing numerous oblong-acute leaves, which are arranged in a distichous manner, recurved, about a foot long, and deep green. *Peduncles* about six inches high, rising from the base of the leaves, and bearing a single large flower on the apex, which measures some three inches or more across. *Flowers* thick and fleshy in texture; *sepals* and *petals* nearly equal, concave, rounded, even at the margins, and of a pale straw colour or waxy white; *lip* ovate and convex, bearing near the base a thick semi-circular ridge, which is made up of numerous truncate plaits and folds, and slightly bi-lobed in front, yellow, of a more decided hue than that of the sepals and petals. *Column* waxy white at the tip, deep violet at the base.

PESCATORIA CERINA, *Rchb. fil., Xenia Orchidacea* i., t. 65; *Floral Magazine*, Second Series, t. 93; *Williams, Orchid-Grower's Manual*, 6 ed., p. 514.

HUNTLEYA CERINA, *Lindl., Paxton's Flower Garden*, iii. 62, fig. 263; *Botanical Magazine*, t. 5598; *Bateman's Second Century Orchidaceous Plants*, t. 183.

ZYGOPETALUM CERINUM, *Rchb. fil., Flore des Serres*, t. 1815.

The genus *Pescatoria* contains many highly curious and beautiful plants, and it was so named in honour of the late M. Pescatore, whose famous collection of Orchids at Chateau Celle-St.-Cloud, near Paris, was at one time the finest in Europe, and whose plants formed the basis of the collection formed by M. Quesnel, at Havre. Botanically, it is said to approach very closely to *Zygopetalum*, and the species here represented was first named by Lindley *Huntleya cerina*, which name it retained in English gardens for many years. It was discovered by the Polish nobleman, Warscewicz, in 1851, on the volcanic mountain of Chiriqui, in Veragua, at an elevation of 8,000 feet, growing on trees of the genus *Trichilia*, which are found there, and also on some species of *Cupania*. It flowers in luxuriance during the autumn months, which, under cultivation, renders it specially acceptable and valuable, as at this season Orchid blooms are somewhat scarce. There are numerous other species of this genus, *P. Klabochorum* and *P. Lehmanni* having already appeared in previous volumes of this work; but besides these, there are many other species and varieties well deserving the care and attention of Orchid cultivators, as their flowers are delicately coloured, they last long in beauty, and are so very distinct from the great majority of the Orchid family.

The drawing for the accompanying plate of this species was taken by our artist from a fine specimen growing in the well-known collection of R. H. Measures, Esq., The Woodlands, Streatham, whose plants are exceptionally well cared for by Mr. Abraham, his gardener.

Pescatoria cerina is a beautiful evergreen plant, entirely destitute of pseudobulbs, merely having a tufty stem, formed in the axils of the leaves; the flowers measure some three inches across, the sepals and petals being fleshy in texture, concave, roundish-oblong, of a pale waxy lemon colour, the lateral sepals being somewhat darker, and the lip clear yellow. It blooms during October and November, and continues in beauty for a very long time.

This plant is successfully cultivated by different growers, in various ways, and in various temperatures; but hitherto they have not proved long-lived plants under cultivation. This, however, arises from the want of knowledge of some special requirement, which, when once we have gained, there will be nothing to prevent us growing it, and all the species of the genus, with ease. Great care is necessary in the management of these *Pescatorias*, and we have found it a good plan to keep them as fair-sized plants rather than to attempt to make large specimens, as the roots generally rot away when the plant attains large dimensions, and this is fatal in most instances, unless the old soil is at once removed, the roots washed, and any dead roots cut away. The plants should then be re-potted and placed in a shady situation. Basket culture is best for them, and good drainage is essential to their well-being, requiring as they do a liberal supply of moisture to the roots all the year round; but it should be allowed to pass away quickly and thoroughly, leaving nothing behind to stagnate. But little mould should be used about their roots, and this small quantity should consist of fibrous peat and sphagnum moss. The plants should be well elevated, by mixing some nodules of charcoal with the soil, and we find the warm end of the Cattleya house the most suitable position for them. Cultivated either in baskets or in pots, the plants, when in flower, should be placed in such a position that the blooms when open are in the line of vision, as in this manner the best effect is produced, and they can be the more easily inspected closely.



LÆLIA MONOPHYLLA.

LÆLIA MONOPHYLLA.

[PLATE 395.]

Native of the Mountains in Jamaica.

Epiphytal. *Rhizome* slender and branched, from which rises numerous stem-like growths; these attain a height of some six or ten inches when strong, each bearing on the summit a single, somewhat coriaceous leaf, which is narrowly oblong, from two to three inches in length, and deep green. *Scape* as long, or longer, than the leaf, one-flowered; individual flowers nearly two inches across; *sepals* and *petals* spreading, nearly equal, oblong, acute, bright orange-scarlet; *lip* minute, three-lobed, the side lobes erect, standing up beside the column, but not enclosing it; front lobe yellow, with numerous small protuberances on the disc. *Column* purple at the tip.

LÆLIA MONOPHYLLA, *N. E. Brown, Gardeners' Chronicle*, xviii., 1882, p. 782; *Botanical Magazine*, t. 6683; *Williams, Orchid-Grower's Manual*, 6 ed., p. 363; *Veitch's Manual of Orchidaceous Plants*, ii., p. 76.

TRIGONIDIUM MONOPHYLLUM, *Grisebach, Flora of the British West Indies*, p. 629.

OCTADESMIA MONOPHYLLA, *Bentham, Genera Plantarum*, iii., p. 526.

The majority of the species of *Lælia* take rank amongst the finest of the Orchid family, but in this genus, as in most other genera of Orchidaceous plants, some few species occur which have but small flowers; even these small-flowering kinds are interesting, and most of our readers will like to see them represented in the pages of the ORCHID ALBUM. Indeed, connoisseurs, as a rule, greatly admire them, and the plant whose portrait we here lay before our readers is a veritable gem. *Lælia monophylla* is by no means a plant new to science, it having been first discovered in Jamaica, some fifty years ago, by the late Dr. Bancroft, whose name is familiar to us from the very beautiful species of filmy fern from the West Indies which bears his name (*Trichomanes Bancroftii*). His discovery was communicated to the late Sir William Hooker, but no living plants came at that time to this country. It was again found some few years ago by Mr. D. Morris, then Director of Gardens and Plantations in Jamaica, but now Assistant-Director of the Royal Botanic Gardens at Kew. It was also found on St. Andrew's Mountains about the same time by Mr. G. Syme, late Superintendent of the Botanic Gardens in Jamaica. Plants from these discoveries reached this country in a living state, and the first plant flowered at Kew at the end of the year 1882. Since then a somewhat large importation of the plant has come to hand, but few of the examples, however, survived. It has no pseudobulbs to support it, and hence it becomes quite a task to import it in a vigorous condition.

The plant here illustrated flowered in our own collection in the Victoria and Paradise Nurseries during the month of August in the present year, and it was exhibited before the Committee of the Royal Horticultural Society of London soon after its blooms opened.

Lælia monophylla is a distinct and pretty species, bearing upon its slender stems linear-oblong leaves, which are solitary and dark green; it forms a creeping rhizome, and grows to a height of from six to ten inches. The flowers are borne upon a slender peduncle, which issues from a small sheath situated on the top of the stem, the colour of the oblong sepals and petals being vivid orange-scarlet; lip minute, yellow, column tipped with purple on the anther-cap. It blooms during the months of August, September, and October, and the flowers continue in full beauty for several weeks.

This little plant requires somewhat different treatment to most *Lælias*. It is remarkable as being the only member of the family which has yet been found off the American mainland, as its native home is on trees which grow on the mountains in Jamaica, at elevations of from 3,500 to 5,000 feet above the sea-level, where the mean temperature is cool. With us it succeeds well in the *Odontoglossum* house, hung up near the roof-glass, in order that it may obtain the benefit of the full light, but yet it requires to be shaded from the strong sun. We also find that shallow pans or baskets are the best to grow it in; these must be well drained, and very little potting material should be used about its roots, but good fibrous peat is the best material to use. This should be elevated into a cone-like mound, and the plant set upon the top; when so placed, the roots can work inside or outside, and no water will lay about its crown. Having no bulbs, it requires a very moist atmosphere, and a moderate amount of water to its roots at all seasons. This plant is found growing somewhat low down on the stems of trees in its native mountains, and in this situation it is subject to rains all the year round, and heavy dews at night, the plants never becoming thoroughly dry. They are also shaded from the hottest sunshine, and obtain an abundance of fresh air, nature providing for them in such a manner that their wants are all supplied; and in a state of cultivation we must endeavour to imitate as near as possible the conditions under which they grow in a state of nature. The cultivator should ever keep a watchful eye upon this little gem, and if the plant does not appear to thrive in one position, or in one aspect, it should be removed to another, for frequently a change of aspect in the same house produces a wonderful effect, and leads to the achievement of success. The best time to re-basket this plant is immediately before growth commences, and in performing the operation the greatest care is necessary, in order to prevent injury to a single root. However, it will not require a fresh basket or fresh soil often, which is a great benefit, for this, like many other small-growing plants, cannot withstand disturbance at the roots.



J. Nees. Hort. Calcutta.

DENDROBIUM TRANSPARENS.

B.S. Williams Publ.

DENDROBIUM TRANSPARENS.

[PLATE 396.]

Native of Northern India.

Epiphytal. *Pseudobulbs* stem-like, slender, from a foot to eighteen inches or more in length, and bearing numerous distichous leaves, which are narrowly lanceolate, membraneous, from three to four inches long, pale green, and deciduous. *Flowers* appearing when the stems are leafless, two or three together, individual blossoms about an inch and a-half across; *sepals* and *petals* white, suffused with rosy mauve or rosy lilac, the petals much broader than the sepals; *lip* obovate-oblong, ciliolate, three-lobed, lateral lobes enclosing the column, creamy-white, with a large blood-coloured blotch at the base, the tip purple.

DENDROBIUM TRANSPARENS, *Wallich. Lindley's Genera and Species of Orchids*, p. 79; *Botanical Magazine*, t. 4663; *Lemaire's Jardin Fleuriste*, t. 68; *Paxton's Flower Garden*, i. t. 27; *Williams, Orchid-Grower's Manual*, 6 ed., p. 304.

The splendid genus *Dendrobium* is one of the most showy of the whole family of Orchids, the species represented in our plate being a very chaste and pretty one. This was first made known to us by Dr. Wallich, whose collectors found it in the vicinity of Nepaul, but it did not reach this country in a living state until the Messrs. Veitch & Sons sent Thomas Lobb to India, and he found the plant growing on the "Garron Hills, at a place called Myrone, 5,000 feet above the sea-level," and from thence it was sent alive to England. This species is abundant in the Himalayas, and of late years many of our collectors have sent it home. When well grown, it flowers in profusion, and it makes a very distinct plant to decorate our stoves, forming a good contrast with other kinds which flower at the same time. Moreover, the plant requires but small space to grow it to perfection. The drawing before us was taken from a plant in our own collection, in the Victoria and Paradise Nurseries, Upper Holloway, in the spring of the present year.

Dendrobium transparens is a pretty and distinct, somewhat small-flowered plant, which is deciduous. It has upright stems a foot or more high, and the flowers appear in pairs or in threes for a considerable length up the well-ripened bulbs, in the same manner as those of *D. nobile*. The individual flowers are about an inch and a-half across; and are somewhat transparent in texture, hence its specific name; in colour they are white, suffused with rosy lilac or pinkish lilac, with a deep blood-coloured blotch at the base of the lip. The blooming season is from the month of March until June, and sometimes it may be found in flower in July, the blooms continuing in full beauty for several weeks. This species is well adapted for growing in small teak-wood

baskets, or in shallow pans, so that they may be suspended near the roof-glass, fully exposed to the sun and light, shading only being necessary when the sun is very powerful, for they grow naturally upon rocks and trees, with a good exposure; and if, by judicious admission of air and an abundant supply of moisture, both to the roots and in the atmosphere, these conditions can be imitated, success will follow. The material we find to suit it best is good fibrous upland peat and sphagnum moss. As we have previously remarked, an abundant supply of moisture during the growing season is necessary, while during the resting season it may be kept dry, but the plant must not on any account be allowed to shrivel; just a sufficiency of moisture being given from time to time, to keep the slender, stem-like bulbs in a plump and fair condition. It is a plant which blooms after the resting season, and when it begins to show its flower buds the specimens will require a little moisture to their roots, to enable them to develop fine flowers, which also last longer in beauty if properly nourished. The East India House is the most suitable place to grow this plant, where it should be suspended near to the roof-glass, in such a position that it may be conveniently syringed on a warm day, as it delights in moisture during active growth, and moisture from the syringe helps to keep away red-spider, which sometimes will attack these plants with slender membranous leaves. As there are a great many species which require similar treatment, they should all be grown together in one place; indeed, if a house can be devoted entirely to Dendrobiums during these growing and resting seasons, the result will be found well deserving of this isolation.

ORCHIDS AT MR. REGINALD YOUNG'S, LIVERPOOL.—We have just received a gathering of Orchid flowers from this gentleman, which are very welcome to us at this dull season of the year (November), when most of our Orchidic pets are suffering from the effects of the Fog Demon. Amongst the Cypripediums are some excellent varieties of *C. Spicerianum*, the variety named *magnificum* being very distinct—a great beauty; also a very large and well-formed flower of *C. callosum*, the dorsal sepal of this bloom measuring, either way across, two inches and three-quarters, the apical portion being broadly banded with white, the lower portion beautifully veined and streaked with purple and green. Another noteworthy flower was *Odontoglossum Rossii rubescens*, a lovely little gem, wholly of a clear soft rose colour.—B. S. W.



CYPRIPEDIUM ELLIOTTIANUM.

CYPRIPEDIUM ELLIOTTIANUM.

[PLATE 397.]

Native of the Philippine Islands.

Terrestrial. *Leaves* distichous, ligulate obtuse, from a foot to fifteen inches long, bright green on the upper side, paler beneath. *Scape* erect, furnished with numerous large bracts, which are white tinged with green, and streaked with lines of deep chocolate, bearing towards the apex from two to five large and showy flowers. *Dorsal sepal* large, ovate-acuminate, ivory-white, suffused with yellow, profusely streaked with broad lines of deep brownish purple, lower sepal smaller, but similar in colour and markings; *petals* long, ciliolate on the edges, gradually tapering to a point, white, flushed with yellow at the base, and spotted with brownish purple, and this colour is continued in lines throughout the entire length; *lip* large, projecting forward, contracted at the base, ivory-white, suffused with brownish purple, and veined with a deeper shade of the same hue. *Staminode* large, beak-like, incurved, furnished with numerous short hairs near the apex.

CYPRIPEDIUM ELLIOTTIANUM, *Reichenbach fil., Gardeners' Chronicle*, n.s. 1888, iv., p. 532. *Veitch's Manual of Orchidaceous Plants*, iv., p. 23. *Lindenia*, iv., t. 186.

This fine species of *Cypripedium* is one introduced recently by Mr. Sander, of St. Albans, during the past few years we have had many fine *Cypripediums* sent from their native homes, amongst which may be named *C. bellatulum*, *C. Curtisii*, *C. Godefroyæ*, *C. Rothschildianum*, *C. Sanderianum*, and many others, the majority of these have been taken advantage of by growers at home for hybridising purposes. The plant we here figure is most distinct and beautiful, and we are indebted to the kindness of Captain Shaw, White Hall, Buxton, who sent it to us for the purpose of illustration in the ALBUM. Captain Shaw's collection is a very fine one, we have known it for many years, and always find something in it to instruct and interest whenever it is visited; the proprietor has studied Orchids for many years, knows their needs, and is continually on the alert for good things.

Cypripedium Elliottianum is a very fine species, which a glance at our plate will certainly verify; it has dark green shining leaves, which are a foot or more long, and an inch broad, and persistent. The scape is terminal, a foot or more high, and bears from two to five flowers, we are told, but at present two flowers, we believe, are the most that it has produced under cultivation. We are assured by its introducer, however, that the collector saw plants which had, in

many instances, produced five flowers, so that when the plant has become thoroughly established and shall have many flowers open at one time, we may expect a grand sight. The dorsal sepal is ivory-white suffused with yellow and streaked with purplish brown, the inferior sepal being smaller and similarly marked; petals long and pointed, standing at nearly right angles, and similar in colour to the dorsal sepal; lip somewhat similar in shape to a Turkish slipper, plush-brown, yellowish towards the top, paler beneath, staminode curved and beak-like, and furnished with numerous hairs. It flowered in the month of May last year (1889), and continued in beauty for several weeks.

We find this *Cypripedium* takes a somewhat long time to establish after its importation, in which it resembles *C. Stonei*, *C. Rothschildianum* and many others. It enjoys a good share of heat, and the East India house is the best place in which to grow it. A liberal amount of water should be given when established, but care is required before it is established that no water is allowed to lie in the heart of the plant, as this is a great cause of decay. The plant is best cultivated in pots, and the side tables are most suited to its requirements, as in this position the plants are tolerably near the glass, which is essential for it enjoys sun and light, and requires shading only during the hottest part of the day in summer. For soil use a mixture of fibrous peat and turfy loam, the greater portion of the fine soil, however, being shaken away; to this add some sharp sand and medium-sized nodules of charcoal, to induce the plant to form strong and vigorous roots, and to produce healthy foliage. The soil should be elevated slightly above the pot's rim, in order to allow the water to pass away more readily, and also to allow the roots greater freedom. This species does not appear to propagate so readily as many of the kinds, but this may arise from the plants not having yet become thoroughly established, so that on this subject we are not in a position to offer an opinion.



DENDROBIUM BRYMERIANUM

DENDROBIUM BRYMERIANUM.

[PLATE 398.]

Native of Burmah.

Epiphytal. Stem-like *pseudobulbs*, tufted, stoutish in the middle, tapering at both ends, from a foot to two feet in length. *Leaves* distichous, lanceolate acuminate, persistent, some five inches long, and deep green above, paler beneath. *Racemes* axillary, confined to near the summit of the pseudobulbs, few-flowering, each flower measuring about three inches across. *Sepals* and *petals* about equal, oblong obtuse, entire, bright golden yellow; *lip* triangular cordate, three-lobed, lateral lobes turned upwards, deep orange, bordered with a short flexuose hairy fringe, anterior lobe ovate-obtuse, greenish yellow with a papillose disc, this is bordered by a very long fringe of branched flexuose ciliolate processes of golden yellow, which are much the longer at the end of the lip, becoming shorter as they ascend towards the side lobes.

DENDROBIUM BRYMERIANUM, *Reichenbach fl., Gardeners' Chronicle*, n.s., xi., p. 474, f. 65. *Ibid*, xvi., p. 688, f. 140. *Botanical Magazine*, t. 6383. *Floral Magazine*, n.s., t. 459. *Lindenia*, iv., t. 183. *Veitch's Manual of Orchidaceous Plants*, iii, p. 24. *Williams' Orchid-Growers' Manual* 6 ed., p. 273.

The plant whose portrait we have here the pleasure of laying before our readers, is one of the most beautiful, and perhaps most extraordinary, of the whole Orchid family, the long ciliolate fimbriation of its lip rendering it quite exceptional; upon its first flowering it caused quite a sensation and a surprise to everyone. There have been many importations said to be this species, but very many of these have proved to be the worthless variety named *histrionicum*. We say worthless advisedly, from many of our readers writing to us asking what is the matter with their *D. Brymerianum*, conclude with the statement that its flowers have fallen before opening. Now this is the peculiarity of the variety *histrionicum* besides having very inferior blooms, the flowers are self-fertilizing, and this causes them to fall before they expand. This form is difficult to discover before flowering, but its pseudobulbs are shorter, and they are stouter than those of the true plant; in fact, we do not remember to have seen a *Brymerianum* with long bulbs prove to be of the spurious form. The typical plant is another amongst the many wonderful new species introduced from Burmah by the Messrs. Low & Co., of Clapton, and was first flowered by W. E. Brymer, Esq., M.P., of Ilsington House, Dorchester, and in whose honour it was named by the late Professor Reichenbach; but it has since then been flowered by many others. Our drawing was taken from a plant in the collection of E. G. Wrigley, Esq., Victoria House, Dukinfield, Cheshire, whose Orchids are in good condition, and where many rare plants are to be found.

Dendrobium Brymerianum is a magnificent and distinct species, having light green foliage, which is persistent, the stems being terete, swollen in the middle, and from a foot to two feet in height. Flowers two to three, proceeding from a short scape near the top of the stem, these are about three inches across, and of a beautiful golden yellow, the side lobes of the lip deeper in colour, and the front lobe somewhat triangular in outline, with a much-branched ciliolate fringe, which is longer than the lip itself. The plant now under consideration bloomed in March, and not long back a plant came under our notice in the month of December, indeed it appears to flower at various seasons of the year, and continues in full beauty for a long time.

This species is free growing, if its wants are supplied, and these are very simple. We find small baskets or pans to suit it best, although we have seen it thriving well in pots. The soil should consist of good fibrous peat (from which all the fine particles have been shaken) and living sphagnum moss; the drainage also must be maintained exceptionally free, as the plant cannot abide anything sour about its roots in potting or basketing. The material should be built up into a cone-like mound above the level, and not too much soil should be used; by this plan the roots of the plant can either penetrate the soil or ramble on the outer surface; this latter many plants appear to enjoy. Large baskets are not necessary, as this plant does not require much soil about its roots; indeed, the less it has about them the better it appears to like it. The plant should be kept moist at the roots during the season of active growth, but when this is completed, all that is necessary is just sufficient water, to keep the bulbs from shrivelling, for the drying-off system should not be carried to extremes. This plant is a native of Burmah, consequently we find the warmest house most genial to it; it should be suspended, say some eighteen inches from the glass, and very little shading given, even through the hottest part of the day in summer. A free circulation of air is essential, and the atmosphere should be well charged with moisture.



DISA GRAMINIFOLIA

DISA GRAMINIFOLIA.

[PLATE 399.]

Native of the Cape of Good Hope.

Terrestrial. Herbaceous, tuberous-rooted. *Leaves* cylindrical and slender, like a thread, few and deep green, these do not appear until after the flowers are past. *Scape* erect, with numerous acute, sheathing bracts, few flowered, but these are of a rich and bright azure-blue. *Helmet* acute, erect, and shortly spurred behind; *lateral sepals* oblong, obtuse; *petals* smaller than the sepals; *lip* oblong, obtuse, toothed at the apex, having several alternate narrow stripes of white, and reddish violet on the disc. *Column* short, tipped with reddish violet.

DISA GRAMINIFOLIA, *Banks, Journal of the Linnæan Society*, xix. t. 34. *Springel, Systema Vegetabilium*, iii., p. 699.

The *Disa* we here bring to the notice of our readers is a most distinct and lovely species, the colour of which is rare, and seldom to be seen in flowers of the Orchid family, we should very much like to see the same colours amongst *Cattleyas* and *Lælias*, and other allied genera. *Disa* is a genus of terrestrial plants which appears to be peculiar to South Africa and Abyssinia, but perhaps as the interior of the country is opened up, many more new and beautiful species may be found in the interior. Mr. J. O'Brien is at present the largest importer of these and many other curious Orchids from these regions, and we hope he may be successful in obtaining many more new and beautiful things. There appears to be more difficulty in importing *Disas* than is thought for, because if they are not removed from the ground just at the right time the bulbs will not survive; and this remark applies in a special manner to the species we here figure, the underground tuber being very small. We mentioned this plant, at our plate 356, volume viii., in describing *Disa racemosa*, which is also a charming and distinct species. This flowered in the collection at Kew, and we have since observed it flowering in various other gardens. We are indebted to the kindness of F. G. Tautz, Esq., for the opportunity of figuring this delicate beauty. The plant flowered in his garden in the month of October, under the care of Mr. Cowley, who has charge of these well-grown Orchids, and was much admired by all who had the good fortune to see it.

Disa graminifolia is a lovely species, and its thin grass-like foliage, from which its specific name is derived, renders it very distinct; but these are not developed with the flowers. The blossoms are of a charming azure-blue, with purple on the tip; they are arranged in racemes, and continue in bloom for a considerable time.

This is a somewhat difficult plant to establish, and even when it becomes

established it requires great attention, in order to produce it in the perfection which we now lay it before our readers. We ourselves have not much experience in growing this plant, but we gather that it grows well in a well-drained pot, and the drainage should have some broken bones added, as we consider this answers just the same purpose as mixing manure with the soil, and it has the advantage of always keeping sweet and clean. The soil should consist of about equal parts of loam, peat, and leaf-mould, to which may be added some rough sharp sand, and some moderate-sized nodules of charcoal, which greatly assist in keeping open the soil, which should be made firm about its roots. During the growing season a liberal supply of water is requisite, but care should be exercised to see that it passes away quickly; and in the winter, when at rest, the soil must be kept in a nice friable condition, but by no means allow it to become quite dry, for as *Disas* are found in a state of nature beside streams, on rocks, and in deep ravines, it becomes necessary to imitate the natural surroundings as near as possible. Slight shade is also necessary, for in their natural habitats they are surrounded with trees, which effectually break the sun's rays. This plant appears to have been introduced some sixty-five years ago, but we are not aware that it was successfully established. It has long been a coveted plant by Orchid growers, and now that it is established in our collections, we hope it may long continue. It is a rare and charming colour, and is most desirable in producing a distinct effect among other Orchids



CYPRIPEDIUM ASHBURTONIAE SUPERBUM

CYPRIPEDIUM ASHBURTONIÆ SUPERBUM.

[PLATE 400.]

Garden Hybrid.

Terrestrial. *Leaves* distichous, ligulate-acute, bright green above, reticulated with a deeper shade, pale green beneath, and from six to eight inches in length. *Dorsal sepal* broadly ovate, pure white in the upper half, tinged with bright light green near the base, streaked with rosy purple, and spotted with rich deep purple, lower sepals similar but smaller; *petals* spreading, oblong-obtuse, bright purplish brown, passing into purple towards the apex, narrowly bordered with pale yellow, and bearing on the edge a fringe of reddish brown hairs; *lip* large, with spreading horns, bright brownish purple, the horns yellow. *Staminode* yellow, with a tinge of emerald-green in the centre. It is a cross between *C. barbatum superbum* and *C. insigne*.

CYPRIPEDIUM ASHBURTONIÆ SUPERBUM. *Williams' New Plant Catalogue*, 1889, p. 23.

Many of our subscribers who are not *Cypripedium* growers may think that we are illustrating this genus somewhat too largely, but we consider there cannot be too many of them, if the species and the varieties are carefully selected, in order to weed out the poor and indistinct kinds. The taste for *Cypripediums* has become very popular of late years, and if an ordinary collection of good kinds is selected, flowers may be had every day in the year, so that there is a decided reason for the prevailing interest which is taken in them, and we hope it may continue. Orchid growers of all classes devote much attention to these plants, and since our old friend Dominy made it so plain how hybrids could be obtained, every grower appears to be raising them from seed, and some of them by thousands. This is very encouraging, but careful selection is necessary in choosing the parents, in order to produce brilliant colours and distinctness in form, both of which are required in order to permanently establish the popular taste. Some of the crosses which have been obtained, and are now young plants, should lead to some startling and wonderful results, far exceeding anything which has yet appeared, and which will render us independent, to a great extent, of foreign importations, save for the purpose of establishing new colours among our garden hybrids.

The form whose portrait we here lay before our readers, is a good one, being much superior in colour to the typical plant, and this shows the result of careful selection in the parents; it is the result of a cross between *C. barbatum superbum* and *C. insigne*, whilst the parents of *C. Ashburtoniæ* were *C. barbatum* and *C. insigne*. This plant was distributed to the public by us in the Spring of

1889, and the figure here given was taken from a plant in our own collection in the Victoria and Paradise Nurseries.

Cypripedium Ashburtoniae superbum is very free in habit of growth; it is also an abundant bloomer, and vastly superior to the type, the flowers being larger, and more beautifully coloured. The leaves are from seven to eight inches long, by about an inch in breadth, the ground colour being bright light green, sparingly tessellated with darker green, whilst the under side is of a uniform pale green. The scape bears a single large flower, the dorsal sepal being some two inches in length, and two and a quarter inches in breadth. It is pure white, streaked and spotted with rosy purple, and flushed with green towards the base, the petals being bright purplish brown, full purple towards the points, and margined with pale yellow; lip large, bright brownish purple, yellow beneath towards the base. It blooms during the months of September and October, and continues six weeks or more in full beauty.

This variety is at present very rare, as, like every hybrid *Cypripedium*, it takes a long time to increase; more especially is this felt when all has to be accomplished from one plant. We find it thrive well when potted in rough, turfy, light yellow loam, and fibrous peat, to which may be added with advantage some sphagnum moss and some nodules of charcoal. During the season of active growth it requires a liberal supply of moisture to its roots, but when this is past, less will suffice. *Cypripediums* are seldom quite dormant, and therefore require the soil to be kept constantly moist; shading is also necessary from the direct rays of the brighter sunshine, but they enjoy all the light possible, as this strengthens the foliage, assists in ripening up the growth, and enables them to produce vigorous and highly coloured flowers. These plants, although not very subject to the ravages of insects, yet at times are attacked by them, and therefore care must be given to prevent them spreading, as everything sour and dirty, and insects of all kinds, must be sedulously removed from about them.



LÆLIA DORMANIANA .

LÆLIA DORMANIANA.

[PLATE 401.]

Native of Rio de Janeiro.

Epiphytal. *Pseudobulbs* stem-like, slender, terete, slightly swollen at the base, when young clothed with membranous sheaths, from six inches to a foot high, and bearing upon the apex a pair of leaves; sometimes, however, three leaves are developed, these are lanceolate in shape, thick and leathery in texture, some four or five inches long, and rich deep green. *Peduncle* erect, rising from a large ovate sheath, scarcely as long as the leaves, and bearing from one to three flowers, the blooms individually measuring about three inches across. *Sepals* and *petals* nearly equal, spreading, the dorsal sepal and the petals ligulate acute, the lateral sepals slightly larger, falcate, the whole olive-green tinged with brown, marbled outside with light vinous purple, and spotted on the margins in front with deep purple; *lip* three-lobed, the lateral lobes large, enclosing the column, recurved at the tips, veined with purplish crimson, the front lobe somewhat quadrate, apiculate, bright rich purplish crimson with a triangular patch of white on the disc. *Column* short, enclosed by the lateral lobes, triangular, white flushed with rosy purple.

LÆLIA DORMANIANA, *Reichenbach fil., Gardeners' Chronicle*, N.S. xiii., 1880, p. 168. *Williams' Orchid Grower's Manual*, 6th edition, p. 356.

This very pretty Lælia, introduced to cultivation within the last few years from Brazil; is a very distinct plant, and is supposed to be a natural hybrid, *Cattleya bicolor* and *Lælia pumila* being its reputed parents. This craze for making plants natural hybrids we think should stop, for it is assuming in the first place that we have exhausted the stock of the world's species, and have nothing to fall back upon but hybrids, whilst that two plants should be supposed to cross which grow at so great a distance apart, is not at all likely, further, the labellum of *L. Dormaniana*, with its large side lobes, does not afford any striking proof of one of its parents being a species quite destitute of side lobes to its lip as *C. bicolor*. *L. Dormaniana*, was discovered by Mr. H. Blunt, whose name is well known as a plant collector for Messrs. Low & Co., of Clapton, and as sending home the first spotted forms of *Odontoglossum Alexandræ*, which the late Professor Reichenbach named *O. Bluntii*. The habitat of this Lælia is the mountainous region in the neighbourhood of Rio de Janeiro, at from 1,500 to 2,000 feet elevation. The plants were sent to this country to Mr. R. Bullen, of Lewisham, who distributed it to the public, and it has since been found and imported in quantity, so that its hybrid origin seems to be very doubtful. This plant was dedicated by Reichenbach to C. Dorman, Esq., of Sydenham, a great and enthusiastic lover of Orchids, and in whose collection many grand specimens and extraordinary varieties have occurred. *Lælia* is a splendid genus of Orchids, very closely allied to *Cattleya*, as is proved by the ease with which they may be crossed

artificially. During the last few years we have received large importations, amongst them are found many new species and varieties, the one we now have the pleasure to lay before our readers in the present illustration being one of them. We are also now coming to the time when some of the artificially raised hybrids at home are beginning to flower, but they are plants which appear to require a long time to make flowering growths from seed, they will well repay, however, the care and trouble bestowed upon them if due attention be given to the selection of parents, for upon this will depend the good or bad results obtained. In the earlier days of hybridising Orchids, little attention was paid to this, but the time is too long to wait for the development of a useless plant; such a style of cross-breeding does not matter so much with soft-wooded plants, which can be flowered in a year or two from seed, but when a decade has to be passed before flowering, it becomes a serious affair. The plant from which our plate was prepared was kindly sent to us from the well-known fine collection of R. Young, Esq., Fringilla, Linnet Lane, Liverpool, and it represents a very good form of the species, although it shows but one flower upon each peduncle.

Lælia Dormaniana is a pretty evergreen plant, compact in growth, with slender, terete, stem-like bulbs which are slightly swollen at the base, and from six to twelve inches high. The leaves are borne in pairs or in threes from the top of the bulbs, and are lanceolate, some five inches long, thick and leathery in texture, and rich green. Peduncle short, from one to three flowered, each flower measuring some three inches across, the dorsal sepal and the petals nearly equal, the lateral sepals larger and falcate, spreading, olive-green tinged with brown, marbled with a light vinous purple, and decorated with deep port-wine coloured spots on the margins; lip three-lobed, lateral lobes large, quite enclosing the column, rosy crimson distinctly veined with purplish crimson, middle lobe very bright purplish crimson. The blooms are produced in late autumn and through the months of December and January, at which times Orchid flowers are scarce, so that this species becomes exceedingly useful; moreover it remains a long time in perfection, for a month or six weeks the flowers may be depended upon, either on the plant or when cut and placed in water. A single bloom also makes an excellent coat flower or buttonhole backed with a green Fern frond; these flowers have particular charms for gentlemen, as they may be placed in water after being worn, and brought out again after a day or two, having all the brilliancy and novelty of a fresh cut bloom.

This plant requires the warmth of the *Cattleya* house, but during the winter months, its blooming season, it must not be rested so long as many of the species which are quite dormant, moreover its slender growths will not admit of it; we have found it to thrive best under just the same treatment as *Lælia elegans* and its varieties, and it will well repay all the care taken of it, by the production of good strong growths and flowers in due season. The best time for repotting this species, if it is requisite, is just before starting into growth, care being taken that the living roots are not injured, but all decayed or decaying ones should be removed with a sharp knife. The plants may either be grown in pots or baskets, but in whatever way they may be treated, the drainage must be good, and due attention must be given that too much material is not placed about their roots.



CALANTHE MYLESII.

CALANTHE MYLESII.

[PLATE 402.]

Garden Hybrid.

Terrestrial. *Pseudobulbs* somewhat oblong and ribbed, tapering upwards, of a pale ashy grey. *Leaves* large, broadly lanceolate, acuminate, membranaceous, much plaited and deep green, falling away before the flower scape is mature. The *spike* rises from the base of the bulb, and grows several feet in length, bearing its flowers in a somewhat nodding manner. The *sepals* and *petals* are ovate-lanceolate, and acute, reflexed, of the purest paper-white; the *lip* is spreading, deeply three-cleft, the lateral lobes oblong, obtuse, erect, closing up to the column, the anterior lobe broadly wedge-shaped, split into two divaricating obtuse and distinct sections; the colour also of the purest white, saving a tinge of lemon-yellow at the entrance to the throat. Spur incurved, filiform, obtuse, about half the length of the lip. Said to be a cross between *Calanthe nivalis* and *C. Veitchii*.

CALANTHE MYLESII, *supra*.

This section of the genus *Calanthe* is both a popular and useful one; the long graceful spikes of showy and delicate flowers are exceedingly attractive and make a fine appearance. They must, however, be arranged with Ferns, fine foliage plants or other Orchids, to be seen to the best advantage, as nearly all of them are entirely destitute of leaves of their own when in flower, but arranged with other plants they have a charming and grand effect. For some time we were restricted in our choice to the forms of the old *C. vestita*—one with a red eye and the other with a yellow one were the only two kinds known—but others have come to hand from time to time, and many hybrids have been obtained. *C. Veitchii* was the first, and for some years it has stood at the head of garden hybrids; but Sir Trevor Lawrence, Bart., M.P., has been very successful in hybridising Calanthes, and has obtained many exceedingly handsome and strikingly distinct kinds, so that with hybrids at home, and kinds introduced from Cochin China, such as *C. Stevensii*, *C. Regnierii*, and the rare *C. Williamsii*, the period over which Calanthe blooms may be had in our Orchid houses is now extended to several months. *C. Williamsii* has already figured in these pages, and its portrait may be found at Vol. iii., t. 134.

We now wish to bring to the notice of our readers a hybrid raised by Mr. Myles, of Ryde, in the Isle of Wight. It is a cross between *Calanthe nivalis*, which is a white *vestita*, and *C. Veitchii*; these are two good parents. *C. Veitchii*, however, appears to have contributed size to the flower, and a certain modification in the shape of the pseudobulb, but nothing is contributed in colour, the flowers being of the purest white possible, flowers of other white Calanthes placed side by side with this one having a decided tinge of yellow. We have the pleasure and honour to hold

the entire stock of this plant, and we intend distributing it to the public in the spring of the present year with other new plants, and as white flowers are in great demand, we look upon it as a great acquisition. It is a free grower, and an abundant bloomer, its long nodding racemes of bloom being very effective.

Calanthe Mylesii is a deciduous plant of great beauty, losing its leaves just before it comes into flower; the bulbs are tapering, angular, and of an ashy grey colour. The flower spike springs from the base of the bulb, and rises to the height of two feet or more, the spike continuing to elongate until the last flower expands; the colour of the flower is paper-white, saving a faint stain of lemon-yellow in the throat. It commences to bloom during the winter months, and its flowering season lasts for a very long period.

This *Calanthe* requires good treatment, although its requirements are very few and simple. It may be grown in either a pot or basket, suspended from the roof, and this we find from experience is the best way to grow all these plants to perfection; for the past few years we have adopted this system with all our plants of *Calanthes*, and our successes have been very marked. The soil we use is good turfy light loam, leaf-mould, and fibrous peat, to this is added a little rough sharp sand, and the bulbs are potted firmly just below the rim of the pot, for as they require a liberal supply of water when in vigorous growth, it is best thus to treat them. Three or four times in the week during hot weather, a little weak liquid cow-manure may be given them, but it must not be given too strong or the roots will suffer, and great injury will accrue; we prefer to take them down and water them, as in this way the soil becomes generally well soaked. Another good plan is to dip them into a tub of water about the same temperature as the house, and after having soaked the soil, the pots should be stood on the floor of the house to drain before returning them to their position. They must be shaded from the sun, as their leaves being thin they would soon receive injury, but they should be subjected to the full light. The bulbs may be rested after flowering, and when they begin to show signs of returning growth they should be potted, and just at this time is the critical one in their management, for if too much water is given before they have become tolerably well rooted failure and loss of flower is sure to follow.



ODONTOGLOSSUM ALEXANDRÆ OUTRAMII.

[PLATE 403.]

Native of the Province of Bogota, U.S. of Colombia.

Epiphytal. *Pseudobulbs* somewhat ovoid, compressed, some three inches high, bearing on the summit a pair of linear lanceolate leaves, which are from nine inches to a foot long, and deep green. *Scape* slender, erect, oftentimes much longer than the leaves, and many flowered. Flowers some three inches across, white flushed with rose, bearing several clusters of brown spots and blotches; *sepals* ovate, lanceolate, with plain edges; *petals* broader than the sepals, undulate and toothed at the edges, carinate behind; *lip* subpanduriform, toothed at the edge, and apiculate, white spotted with chestnut-brown, bright yellow on the disc; *column* arching, with a pair of jagged toothed wings.

ODONTOGLOSSUM ALEXANDRÆ OUTRAMII, *supra*.

The large number of varieties of *Odontoglossum Alexandræ* which have been brought to this country from their native wilds is most wonderful, but we are told that the numbers are so much diminished that it is now a difficult matter to gather together a fair consignment, so that in less than thirty years our collectors have caused a dearth in the land where, before, abundance prevailed; still the extent of ground over which the species exists is very great, and good varieties are still likely to reward the search of the energetic collector, moreover, every small plant as well as the larger ones should be grown and bloomed, as we have noted some very excellent forms spring from small pieces which had never given an intimation of flowering before. The reason why it is the small pieces so often produce unexpected results is not far to reach and to solve; the larger plants which are flowering when the traveller finds them, if anything special, will be marked as a matter of course, and their records come home with them; but it is the smaller pieces in the neighbourhood gathered as makeweights that have no records: these are the plants which, in all probability, are seedlings from fine flowering plants, and which may produce many varieties, perhaps, of superior merit, and hence a district where fine forms have been found, will, in all probability, be famous for good varieties for many years. The variety we here introduce to our readers is a charmingly spotted form, and is one which we received through the kindness of A. Wilson, Esq., of Westbrook, Sheffield, who has previously sent us some fine varieties of this species; this one is named in compliment to Mr. A. Outram, who has represented our firm for upwards of twenty years, and has had the opportunity of inspecting most of the best collections in cultivation, both of Orchids and other plants, which has given him a good practical knowledge of plants in general.

Odontoglossum Alexandræ Outramii is a splendid variety, compact in growth, and handsome when in flower. The bulbs are about three inches in height, with leaves ten or twelve inches in length, and of a lively green; the scape proceeds from the base of the bulb, growing from eighteen inches to two feet long, and having some twelve or thirteen flowers. As the plant gains strength, more flowers will be developed; in fact, the raceme may become paniculate. The sepals are white, flushed with rose colour, and the petals are also white, with two or three clusters of chestnut-brown spots and blotches, these forming a charming contrast with the lighter-coloured forms of *O. Alexandræ*. It blooms during the months of January and February, and continues in perfection for some weeks.

The forms of *Odontoglossum Alexandræ* vary considerably in their time of flowering, which arises from the difference in the time of finishing their growth. So much, indeed, do they vary, that we have known, in collections where the species is largely grown, some examples in flower throughout the entire season. This renders them very valuable, for an *Alexandræ* flower is always acceptable, and to either sex; the flowers also withstand the London air as well, or better than many Orchids, and it is quite wonderful that a plant whose home is at some 7,000 to 8,000 feet elevation should thrive so well in such a crowded and dense atmosphere.

The *Odontoglossums* require care at the time when their scapes begin to become visible, to protect them from the small snails, *Helix alliaria* and *H. purus*, two species which get imported into the houses in the sphagnum moss, and which are always in search of food. The young and delicate spikes appear to have a peculiar temptation for them; they must therefore be searched for by day, and also in the evening by lamp-light; at this latter time they may be caught prowling about seeking what they may devour. A chapter treating upon these, as well as the insect pests which infest Orchids and Orchid houses, will be found in the pages of the *Orchid Growers' Manual*, to which we beg to call our readers' attention. These plants must be kept in a clean and healthy state to be enjoyed; and as many of the insect pests injurious to Orchids are imported with them and introduced to our houses unwittingly—as in the case of our native snails—all plants should be well searched before admission is given them to the Orchid house, for these insects soon increase and multiply in the warm atmosphere.

The *Odontoglossum* now under consideration requires the same treatment as the typical plant; it should be grown in a cool house, and potted in peat fibre and living sphagnum moss. The moss should be clean, and well picked, and as the soil decays it must be removed. Do not wait for any particular potting season, but when the soil shows signs of being spent, it should be at once removed—“delays are dangerous.”



J. Eugène Fitch del. et lith.

E. S. Williams & Son Publ^{rs}

CATTLEYA MAXIMA MARCHETTIANA.

CATTLEYA MAXIMA MARCHETTIANA.

[PLATE 404.]

Native of Ecuador and Northern Peru.

Epiphytal. *Pseudobulbs* clavate, from nine to twelve inches high, slightly compressed, bearing a single leaf, somewhat oblong in shape, some five inches long, and two inches broad, thick and fleshy in texture, and pale green. *Scape* erect, bearing numerous flowers, the flowers individually are about five inches across; *upper sepal* oblong-acute with smooth edges, lateral ones slightly larger, falcate; *petals* broader than the sepals, with waved edges, all of a rich crimson-lake, streaked with lines of a paler hue; *lip* three lobed, the front lobe emarginate, much frilled, or crisp on the edge, with a broad streak of yellow in the centre, together with several radiating streaks of the same colour in the throat, the ground colour being beautiful crimson-lake with lighter streaks, and having a marginal border of white. *Column* slender, white.

CATTLEYA MAXIMA, *Lindley Genera and Species of Orchidaceous Plants*, p. 116; *Botanical Magazine*, t. 4902; *Illustration Horticole*, t. 29; *Xenia Orchidacea* i., t. 95. *Williams' Orchid Grower's Manual*, 6 ed., p. 189.

EPIDENDRUM MAXIMUM, *Xenia Orchidacea*, ii., p. 29.

CATTLEYA MAXIMA MARCHETTIANA, *supra*.

This *Cattleya*, to which the name *maxima* does not apply in the year of grace, 1890, is a native of Ecuador and Northern Peru, and was first discovered by Ruiz and Pavon upwards of a century ago. It was from the flowers collected by these two Spanish botanists, that afterwards came into the hands of Dr. Lindley, that the plant was named and described; but it was not until about the year 1844 that it first came under our notice. We used, in those times, to consider it a very pretty species, but during the last few years, the native habitats of the orchidaceous plants of South America have been so thoroughly searched, that this species, as well as others, have yielded many varieties which prove to be superior in colour to the typical species; one form called *Cattleya maxima Backhousiana* we have already figured in these pages, at Vol. v., t. 198. This is a beautiful and richly coloured form of this now well-known species, and it is still rare in collections, but the variety here depicted, as a glance at our illustration will show, is far superior to that in the richness and colouring of its flowers; and the fact of its being so thoroughly distinct from any other *Cattleya*, will at once render it a great acquisition to the family to which it belongs.

The specimen whose portrait we here have the pleasure of laying before our readers, was flowered by G. Marchetti, Esq., of Manor Heath, Halifax, and to whom we have much pleasure in dedicating such a splendid variety. It is the first and only

plant that has come under our notice, and as it cropped up out of an importation with others of the type, many of our readers will be anxiously looking for other startling novelties from amongst their imported plants; indeed, it is this chance of new things that induces many to purchase newly imported or unflowered plants.

Cattleya maxima Marchettiana is a compact-growing plant with light-coloured, club-shaped bulbs, which are some twelve inches high, and quite distinct from any known species of *Cattleya*; the bulbs produce a single leaf which is about five inches in length, and nearly two inches in breadth; the peduncle rises from a sheath at the top of the pseudobulbs, and bears three or more flowers, which, as the plant gains strength, will increase in floriferousness. The blooms of this variety are similar in size and shape to the species, being some five inches across, blotched with crimson-lake and deep purple, forming a noble flower. It blooms during the autumn and winter months, and continues in full beauty for a long time if the flowers are kept free from damp; spotting from damp is a calamity which frequently befalls the blooms of *Cattleyas*, especially if kept in too low a temperature.

This variety of *Cattleya maxima* requires the same treatment as the original species, and it should be exposed to as much light as possible; care, however, is necessary in shading, and this is a maxim that should be borne in mind upon all occasions. The object of shading is to exclude the too strong rays of the sun, and to prevent the exposure of the plants to it, but this is frequently done when the sun does not shine, or the shading material is frequently left over the plants after the danger is past. This practice should not be followed if weak growths are to be avoided, for these are produced by too much shading: strong and well-ripened bulbs are the way to secure healthy plants as well as flowers of good substance and colour. To have these, particular care must be given to the shading; it should not be allowed to shelter the plants from the benefit of the full light immediately upon the fierce rays passing over, and a good supply of air is needed. In this way alone can *Cattleyas* be induced to produce flowering shoots. The pots for the reception of the plants must be well drained, and for potting material use good fibrous peat, from which all the fine part or soil has been shaken away. This should be mixed with good living sphagnum moss, and during the time of potting should have the addition of some fair-sized nodules of charcoal to keep the material free and open. If no charcoal is available for this purpose, some pieces of drainage material should be used, the whole being built up above the rim of the pot into a cone-like mound, and made firm and hard, for firm potting is essential to all *Orchids*, eastern or western.



August Fitch del. et lith.

ONCIDIUM LARKINIANUM.

B.S. Williams & Son Publ'rs

ONCIDIUM LARKINIANUM.

[PLATE 405.]

Native of Brazil.

Epiphytal. *Pseudobulbs* oblong-obtuse, compressed, ribbed, deep green tinged with brown. *Leaves* mostly in pairs from the apex of the pseudobulbs, lanceolate, acute, carinate beneath, some six or nine inches long, and deep green. *Scape* radical, many-flowered, the individual flowers large, measuring upwards of two inches across, and very showy; *dorsal sepal* somewhat ovate, the lateral ones connate, ground colour yellow, transversely streaked with bright chestnut-brown, petals somewhat clawed at the base, roundish in outline, the centre chestnut-brown with a broad marginal border of rich yellow, into which run numerous streaks and spots from the centre; *lip* clawed at the base, deeply bilobed in front, and lobed and undulated at the edges, front lobe clear rich yellow, the claw spotted and dotted with chestnut-brown, the side lobes small, tipped with yellow. *Column* short, obtuse, furnished with a pair of short yellow wings.

ONCIDIUM LARKINIANUM, *Gower, in Garden*, vol. xxxvii., p. 325.

This charming plant would appear to be a near relation to the equally charming *Oncidium Forbesii*, *O. prætextum*, *O. Gardnerianum*, and *O. Marshallianum*—in fact, by its flowers one might be led to suppose that *O. Gardnerianum* and *O. Marshallianum* had something to do with its parentage, as the sepals and petals resemble those of the former plant, and the lip the latter; but no indication is found in the pollen masses of its being a hybrid, and indeed we are not such believers in natural hybrids as some of our fellow Orchid growers appear to be. The plant has only been seen, we believe, in the collection of J. Larkin, Esq., by whom it was exhibited before the Committee of the Royal Horticultural Society, in the month of March in the present year, and through whose kindness we are here permitted to lay a figure of it before our readers.

Oncidium Larkinianum is a compact evergreen plant, having ribbed deep green pseudobulbs, tinged with brown, some three or four inches in height. The leaves are borne mostly in pairs, about eight inches in length, by an inch and a half in breadth, and of a rich deep green. The scape figured is simple, but since this plate was prepared we have seen another plant flowering in Mr. Larkin's collection with a branched spike. The racemes are many-flowered, the flowers being large and showy. We only know of this species as flowering in the month of March; but the blooms last a very long time in full perfection. The ground colour of the sepals is yellow barred transversely with

bright chestnut-brown, the petals being dark brown in the middle, broadly bordered with rich yellow, and bearing numerous streaks and spots of the same colour as the centre of the petals. The lip is large, deeply bilobed in front, and waved at the edges, the colour being golden yellow; the narrow part of the lip at its base and the disc are freely spotted with chestnut. This plant is, we suppose, found with its near relatives in the Organ Mountains of Brazil, which range, although covering a considerable area, does not attain any great altitude. We have, however, found many plants from these regions thrive well under cool treatment, and this plant we opine should be grown at the cool end of the Cattleya house. When its growth is completed, it should have a season of rest in the Odontoglossum house, from whence it should be brought and restored to its former position when its flower spike or spikes appear. It belongs to a set of plants which we have always found to dislike a great amount of soil about their roots, but what it has should always be kept in a sweet condition, and this can only be effected by thorough drainage, which we contend is of more importance in the cultivation of Orchids than of any other plants. White scale will prove troublesome to these plants, but this must not be allowed to accumulate; they should be kept clean by frequently wiping and sponging with soft soap and warm water.



ODONTOGLOSSUM YOUNGII.

[PLATE 406.]

Native of Mexico.

Epiphytal. *Pseudobulbs* clustered, sub-rotund, compressed, sulcate, rough on the surface, and bronzy green in colour, bearing on the apex a single leaf, which is some five inches or more in length, by about an inch in breadth, lanceolate, acute, carinate beneath, and rich deep green. *Scape* radical, much longer than the leaves, furnished with numerous oblong-acute bracts, and bearing from one to three or more flowers, which are somewhat thick and fleshy in texture and nearly two inches across. *Sepals* oblong-acute, slightly incurved, the ground colour pale yellow, heavily marked with transverse spotted bars of dark chocolate; *petals* much broader than the sepals, ovate, acute, the ground a pale yellow, which is marked by large spots of rich deep chocolate; *lip* transversely reniform, clawed at the base, the margin entire, and undulated, white, streaked with short lines of reddish brown, and bearing a pair of large dark chocolate spots in the centre; *disc* fleshy, yellow, more or less streaked with reddish brown. *Column* short and stout, reddish violet.

ODONTOGLOSSUM YOUNGII, *Gower, in The Garden*, xxxvii., p. 84.

We have much pleasure in laying a portrait of this, which appears to us to be a new and distinct species of *Odontoglossum*, before our subscribers. The plant originated in the collection of R. Young, Esq., Linnet Lane, Liverpool, and after whom it is worthily named. It is a very distinct plant, much more so than some we are frequently enabled to lay before our readers, and we trust it will flourish and flower yet more freely than it has hitherto done. Some who have seen the plant in flower ascribe a hybrid origin to it, supposing it to have been derived from *Odontoglossum Rossii* crossed with some other species. Our drawing was made from the only specimen that we know to exist, which is in the collection of R. Young, Esq., Linnet Lane, Liverpool, from whom we received the plant for figuring. This plant was introduced by Messrs. Shuttleworth & Co., who have kindly given us the following information respecting its introduction with a batch of *O. Rossii* :—

“With regard to the origin of *Odontoglossum Youngii*, we have been looking over all our old letters from the collector, but cannot find the exact locality; however, that matters very little. A few years since, if we remember rightly, one of our collectors wrote, having seen some yellow *O. Rossii*, which he called *O. Rossii aureum*, and of which he forwarded a small box containing about sixty plants; they arrived in very bad condition, and we received only about four alive. We did not think much of it, until twelve months later

a plant flowered, and was found to be *O. aspersum*. We then gave our collector orders to send us a quantity. He wrote back, saying he could not find many in the old locality, near Orizaba, but he would proceed a little further north and try there. Luckily he found a nice batch growing together with *O. Rossii*, and this plant turned up among them. We cannot find any locality in his letters but the Cordillera, north of Orizaba, running parallel with the coast."

Odontoglossum Youngii is a dwarf-growing species, and one which we advise to be grown in a shallow basket, in like manner to *O. Rossii*, and it should be treated in the same manner as that species. The pseudobulbs are roundish-ovate, bearing a single leaf. The scape bears one or two flowers, but in all probability, as the plants become stronger, more flowers will be borne on the scape; these flowers have a delicious aromatic odour. It requires to be potted in good fibrous peat and sphagnum moss, and the pots or baskets must be well drained. It succeeds very well in the ordinary cool house with other species of *Odontoglossum* of the *Alexandrae* and *Rossii* types; but we do not think it would be well to subject it to such a low temperature as that to which the last named plant may be exposed with impunity.



DENDROBIUM ALBUM.

[PLATE 407]

Native of Southern India.

Epiphytal. *Pseudobulbs* stem-like, pendulous, from a foot to two feet long, light green. *Leaves* some five inches in length, and an inch and a half in breadth, oblong, acute, membranous, and rich green. *Flowers* borne upon the current year's growth, in company with the foliage, and mostly in pairs; the *dorsal sepals* and *petals* nearly equal; the *lateral sepals* somewhat larger and more triangular, all of a creamy white; *lip* three-lobed, the lateral lobes erect, enclosing the column; middle lobe somewhat acute, deflexed in front, the surface downy, white stained with yellow on the disc, the margin bearing a slight fringe.

DENDROBIUM ALBUM, *Wight, Icones*, t. 1645; *Paxton's Flower Garden*, ii, p. 175.

DENDROBIUM AQUEUM, *Lindley, Botanical Register*, t. 54. *Botanical Magazine*, t. 4640.

In the present species we have a member of the Dendrobes which has hitherto been at a discount with growers, although it has been known to cultivation for nearly fifty years; but in these days when white flowers are so much in demand, it should be considered an acquisition, more especially as the flowers are produced with its rich green leaves, and not upon bare and leafless stems. We have adopted Wight's name in preference to that of Lindley, for we are under the impression that the learned Doctor was misled by some poor flowers which opened first in the establishment of the Messrs. Loddiges, of Hackney, and caused him to call them green and watery flowers, a description which those figured by us in this place certainly do not deserve.

For the opportunity of figuring this species, and thus making it more known to the Orchid growers of this country, we are indebted to the kindness of Thomas Statter, Esq., Stand Hall, Whitefield, Manchester. It is a species which, we believe, deserves more extensive circulation, and we have little doubt that some fine varieties will be found to exist amongst the plants recently introduced.

Dendrobium album is a beautiful species, which maintains its foliage until after the flowers are fallen. The flowers last some time in beauty, and are of a soft creamy white, except the base of the lip, which is stained with light yellow; they are produced singly, or in pairs, on the opposite side of the stem to the leaves, and it thus makes a pretty ornament, backed as the flowers are by its bright green leaves. The flowers are mostly produced at the end of summer, or beginning of autumn; but when the growth has been made late, we have known the plant to flower as late in the season as the month of

November. The species was first flowered by Messrs. Loddiges, of Hackney; but the gentleman to whom we are indebted for the plants now to be found in this country is Major-General Berkeley, of the Indian Army, from a district of south-western Bombay, where the rainfall is excessive. The plant must therefore be grown in a very moist atmosphere, and it also likes an abundance of heat when growing. We have found this plant to thrive upon blocks, but these will only accommodate small plants, and we therefore recommend the use of shallow hanging baskets in which to grow the plants, draining the same thoroughly, and using for soil good fibrous peat and living sphagnum moss, which should be made firm in the basket, so that the plant does not rock about. Nothing is more distressing to any plant than to have its roots strained every time the basket is taken down to dip or to remove it, and which, if continued, eventually leads to its death. The plant should be well exposed to the sun during the summer months (its season of growth), shading only from the burning sun in the middle of the day; during the winter a somewhat cooler and drier house will suit it admirably, care, however, being taken that the stems do not suffer from over draught, and at the same time from too much cold. The cool end of the Cattleya or intermediate house will be the most suitable position for it during the winter months, from whence it may be removed when re-potted early in spring.



LYCASTE GIGANTEA.

[PLATE 408.]

Native of Central America.

Sub-terrestrial. *Pseudobulbs* oblong-ovate, some four or six inches high, smooth and dark green, bearing a pair (sometimes three) oblong-lanceolate leaves, which are from one to two feet in length, much plaited, and deep green. *Scape* nine inches to a foot high, or sometimes more; one-flowered. *Flower* large, upwards of six inches across; *sepals* and *petals* nearly equal, linear, lanceolate, obtuse, the *lateral sepals* being slightly the larger and falcate, all of a yellowish olive-green; *lip* three-lobed, the lateral lobes erect, acute, and small, the front lobe panduriform and recurved at the tip, the whole of the front lobe being of a rich velvety maroon, with a marginal border of mauve-orange, and at the base is an emarginate hard fleshy substance, the outer edge ciliolate.

LYCASTE GIGANTEA, *Lindley, Botanical Magazine*, t. 5616; *Botanical Register*, 1845, t. 34; *Williams' Orchid Grower's Manual*, 6 ed., p. 378.

MAXILLARIA HEYNDERYCXII, *Morren, Annales de Gand*, 1845, t. 9.

The species we have now under consideration is a somewhat old inhabitant of our stoves, having been introduced by M. Linden, of Brussels, a little more than forty years ago, from the forests in Merida, where he found it growing at no great altitude; the species had, however, been previously found by Purdie, in Santa Martha, and also by Hartweg, in Central America. Our first knowledge of the plant was from a specimen which flowered with us in 1856, and this plant was said to have been brought from Guayaquil, so that the species would appear to be widely distributed naturally, as a consequence of which there are to be found considerable variations in size and colour of the flowers. It cannot be called a very gay-coloured species, especially when compared with some of this genus, but its large flowers are very distinct and beautiful, commending itself to the attention of all lovers of Orchidaceous plants. Our artist's drawing was taken from a plant in the collection of H. Tate, Esq., Allerton Beeches, Allerton, Liverpool, in March last.

Lycaste gigantea is a bold-growing evergreen plant, with large and stout bulbs, bearing from the top two or three deeply plaited leaves, which sometimes exceed two feet in length, the colour being rich deep green; the scape is erect, bearing a single large flower, which varies considerably in size, but less in colour. There are some varieties, however, much darker than others, the usual colour for the sepals and petals being yellowish olive-green, with the lip of a more or less dark maroon of a velvety appearance, and this is bordered round the margin with

rich orange. The plant would appear to be variable in its time of flowering; with us it bloomed in the months of June and July, and this year we have also seen a beautiful variety flowering at this time with Mr. Horsman, of Colchester; at other times we have seen the species flowering during the winter months. No particular season can therefore be depended upon for its blooming, but at the same time it is a plant which may be easily retarded, should it be wanted in flower at a later season. This plant appears to enjoy a little more warmth than *Odontoglossums*, but yet it thrives best in a low temperature. We grow the plant in a temperature between that of the *Odontoglossum* house and the *Cattleya* house, and from its large leaves it is best treated as a pot plant, using good fibrous peat and sphagnum moss, and employing well-drained pots. During the period of growth it likes an abundant supply of water, and it also enjoys a considerable amount of shade. After its pseudobulbs are formed, and plump, the plant may be put to rest by withholding the water, but not to such an extent as to cause shrivelling, for by this system no good can result to any such plant as the one under notice.

It is propagated by dividing the bulbs just after flowering; but it is always safest to have a young shoot on the divided bulbs, rather than to trust to the breaking out of latent buds, which sometimes are a long time making their appearance. We are not aware that this species is liable to insect attacks; the only thing we have ever noted is green fly upon the young growths, and this any Orchid grower will remove as speedily as possible.



VANDA TERES ALBA

VANDA TERES CANDIDA.

[PLATE 409.]

Native of Northern India and Burmah.

Epiphytal. *Stems* scandent, emitting a large quantity of roots, and bearing terete leaves, which are from three to four inches long, and deep green. *Raceme* ascending, bearing usually a pair of flowers, although at times one only is produced; they measure some four inches across. *Dorsal sepal* erect, much smaller than the lateral ones; *petals* sub-rotund, much larger than the sepals, slightly undulated, all pure white; *lip* three-lobed, lateral lobes large, rolled over the column, forming a hood, white on the exterior, stained with pale yellow on the inner sides; anterior lobe narrow at the base, dilated and emarginate at the apex, white, faintly flushed with rose on the disc. *Spur* infundibuliform.

VANDA TERES CANDIDA, *Reichenbach fil.*, in *Gardeners' Chronicle*, N.S., iv., p. 225; *Williams' Orchid Grower's Manual*, 6 ed., p. 610.

VANDA TERES ALBA, *Hort.*

This is the purest white form of *Vanda teres* that has yet come under our notice; for several years we have been aware of the existence of an albino form of this species, and we have waited anxiously to see it. Various plants have from time to time been pointed out to us as being the veritable plant, but upon examination, they have proved to be but pale forms of the type. More especially was this the case when, after making a long journey, we were much annoyed to find only a specimen in which the sepals and petals were white more or less flushed with rose, whilst the lip was almost as much coloured as the typical plant. The first white form of this species was flowered by Mr. W. Whittaker, gardener to Lord Crewe, at Crewe Hall, Cheshire, and from this plant the variety was named by Professor Reichenbach. The specimen here illustrated was flowered in the gardens of His Grace the Duke of Marlborough, at Blenheim, in Oxfordshire, under the care of Mr. Whillans, and we must congratulate him upon being the first to show us this chaste and beautiful variety.

Vanda teres candida resembles the typical plant in its habit of growth and general appearance, but upon closer examination it will be found to be more slender in its stems, and the terete leaves also are more acute, whilst in their colour the leaves are paler in the shade of green. The raceme on this plant bore only a single flower, but should it eventually produce a many-flowered raceme as in the variety known as *V. teres Andersonii*, it will then prove itself to be a most effective and charming variety, as, in addition to the size of

the flowers, the sepals and petals are of the purest white, and the lip is also white except a faint tinge of pale rose on the disc and the inner side of the lateral lobes, which are stained with lemon-yellow. This is a plant which, like the species, enjoys all the sun and light which we can give it, and therefore it should be hung up or placed close to the glass in the warmest house during the growing season, at which time an abundance of moisture is necessary, both in the atmosphere and to its roots, and the syringe should be kept constantly going. At this season the East Indian house is the proper position for it, but after growth is finished, in order to give the plants a thorough rest, and to enable them to ripen the growth well, we advise the entire cessation of water, after which the plants should be removed to the *Cattleya* or intermediate house; here they should be kept both cool and dry, or nearly so, but the leaves should never be allowed to shrivel. In the spring months the flower spikes will begin to show, when the plants must be removed to their former warmer position, and water again be given them, moderately at first, but the quantity may be increased as the days lengthen and the sun brightens. The various forms of *Vanda teres* flower very freely with us, and we trust the variety here depicted will prove equally floriferous. The house in which we grow these *Vanda teres* is one devoted to the culture of *Crotons* and similar plants, and which is never shaded. The *Vandas* are grown in well-drained pots, the compost used being simply a mixture of sphagnum moss, mixed with various-sized nodules of charcoal. The plants when potted are plunged in a layer of sphagnum moss, and placed close up to the glass, being freely watered with the syringe. We have plants varying from a foot to eighteen inches and two feet in height, grown in this manner, and they flower most profusely every season; when these plants become too tall for the position in which they stand, they are cut down, and the tops are potted in a similar mixture to that recommended above for the old plants. At first these tops receive a somewhat shaded treatment, until they make fresh roots and become established, and afterwards they are placed in the full sun alongside the older plants.



ZYCOPE TALUM CRINITUM COERULEUM.

ZYGOPETALUM CRINITUM CÆRULEUM.

[PLATE 410.]

Native of Brazil.

Epiphytal. *Pseudobulbs* stout, ovate, bearing numerous leaves from the apex of the pseudobulbs, and which are strap-shaped, lanceolate, strongly veined or plaited, rich deep green; besides these leaves there are several produced from the base of the pseudobulb, and which envelop it when young, but they are not persistent, usually dying away by the time the growth is completed. *Scape* radical, erect, appearing with the young growth, shorter than the leaves, and bearing about half-a-dozen large and showy blooms. *Flowers* three inches or more across; *sepals* and *petals* oblong-acute, nearly equal, ascending, ground colour yellowish green, heavily blotched and streaked with ferruginous brown; *lip* large, ovate, emarginate, undulated on the margin, pubescent, white, marked with forked and radiating, downy lines of bluish purple.

ZYGOPETALUM CRINITUM, *Loddiges, Botanical Cabinet*, t. 1687; *Botanical Magazine*, t. 3402. *Williams' Orchid Grower's Manual*, 6 ed., p. 619.

ZYGOPETALUM CRINITUM CÆRULEUM, *Hort., Williams' Orchid Growers' Manual*, 6 ed., p. 616.

This plant is considered by some authors to be a variety only of an older plant, well known and much admired, by the name of *Zygopetalum Mackayi*, which blooms during the mid-winter months; the present plant is both a winter and spring bloomer, flowering in great profusion, and oftentimes throwing two scapes from a single growth. This, the best form of *Z. crinitum*, bears the name of *cæruleum*; another variety, or perhaps the typical form, has the lip with downy lines of rosy red or pinkish hairs. Blue, however, being the most unusual colour amongst orchidaceous plants, obtains more notice from cultivators, and this colour, in various shades, is quite characteristic of the genus, a few examples of which have already appeared in these pages, of which *Z. Clayi*, t. 50; *Z. rostratum*, t. 78; *Z. Gaudierii*, t. 28; and *Z. Burkei*, t. 142, may be taken as examples. The plant here figured flowered in our own collection, in the Victoria and Paradise Nurseries, during the spring months of the present year, where the plant usually contributes largely to the display we are enabled to maintain at that season.

Zygopetalum crinitum cæruleum is a free-growing evergreen plant, easily cultivated into a handsome specimen, and blooms profusely during the winter and spring months, the flowers being large and showy, lasting a very long time in full beauty. During the summer season, its period of growth, it requires a

liberal supply of water, both to its roots, which are large and fleshy, and also in the atmosphere; whilst during the winter a sufficient quantity must be given to keep the large roots from shrivelling. Unless this is kept well in mind, the flower spikes will suffer and come up weak, and the flowers be proportionately poor. It should be treated as a pot plant, and the pots should be well drained, using for soil good peat fibre, and a little light turfy loam; this may be considered an innovation by some, but we have found the plant invariably thrive better when so potted, than when potted with peat alone.

It may be propagated by dividing the rhizome, but the plants so divided are usually some time before growing into a flowering state, as the divisions are only the back portions of the plant which have to develop an eye before breaking; the front portions of the plant having a leading growth should always be left with some of the old pseudobulbs upon them.

CHAMELEONS AS FLY-CATCHERS.—Having recently paid a visit to an amateur Orchid grower in the East End of London, we remarked, on looking over his collection, that green-fly or aphides were not represented, in any shape or form. "Oh," said our friend, "my Green Frogs and Chameleons take care of all such guests." And here he pointed to some fine Chameleons, quietly sunning themselves on the branches of climbers on the roof. It was a perfect surprise to us to see the lively habits of these creatures, having been taught to believe them very slow in their movements; instead of this being the case, they travel rapidly, and the unerring precision in which a fly is glued to their tongue and passed into the mouth is something wonderful to behold. The curious construction of the eyes, the changes in colour, and their marvellous and weird-like limbs, all tend to constitute these saurians charming pets for lady Orchid growers. They are natives of the northern part of Africa, and appear to remain many weeks during the winter with but little sustenance.—W. H. G.



DENDROBIUM SCHNEIDERIANUM

DENDROBIUM SCHNEIDERIANUM.

[PLATE 411.]

Garden Hybrid.

Epiphytal. *Pseudobulbs* erect, stem-like, compressed, nodose, the internodes streaked with white. *Leaves* deciduous. *Flowers* borne upon long pedicels, mostly in pairs, between three inches and four inches across; *sepals* lanceolate, acute, the edges plain; *petals* much broader than the sepals, undulate, the ground colour creamy white, suffused with rosy purple at the tips; *lip* somewhat cordate at the base, the front lobe drawn out into an acuminate point, side lobes rolled over the column, the base downy, stained with orange-yellow, through which run numerous radiating lines of rich purple; in front of the orange-yellow is a zone of creamy white, the acuminate point being coloured, the same as the points of the sepals and petals. *Column* hidden, white, streaked with darker lines.

DENDROBIUM SCHNEIDERIANUM, *Rehb. fil.*, in *Gardeners' Chronicle*, 1887, i. Third series, p. 209. *Veitch's Manual of Orchidaceous Plants*, iii., p. 90.

The genus *Dendrobium* is now a very large one, and the number of species and varieties which adorn our stoves are both numerous and beautiful. The one whose portrait is here produced is most chaste and elegant, arguing well for the rich combinations which we may hope to see when the many seedlings which now are in their infancy have arrived at a flowering stage. Natural hybrids amongst the species of this genus would not appear to be common, but some examples have from time to time appeared, to which a hybrid origin has been ascribed; these, however, have been collected in sufficient quantities to cast a doubt upon this supposition, and they have, moreover, been collected in wide and distant localities. Our specialists at home have produced a few very beautiful kinds, but it must be confessed that this genus has not received the attention at their hands which the "Lady's-slipper" family has done. The first hybrid *Dendrobium* was obtained by an old and respected friend of ours, Mr. Dominy, when engaged in the nursery of the Messrs. Veitch, at Exeter, and it very deservedly bears the name of *Dominianum*. It is a very bright and cheerful flower, raised between *D. nobile* and *D. Linawianum*, the latter being then known under the erroneous name of *D. moniliforme*; since then we have had *D. Ainsworthii* and *D. Ainsworthii roseum*, raised by Mr. Mitchell, the last-named variety being figured in these pages, t. 20. The same forms were also obtained by Mr. Osborne, when gardener to H. J. Buchan, Esq., at Southampton. Grander forms of the same cross have also been obtained by Mr. Seden, at Messrs. Veitch's, in *D. splendidissimum* and *D. splendidissimum grandiflorum*. *D. Leechianum* is also a superb form, raised by Mr.

Swan, when at Fallowfield, Manchester; this also is from the same parents as the above. Sir Trevor Lawrence has also been a successful hybridiser of Dendrobiums, and we have seen some exquisite flowers in his garden at Burford Lodge, Dorking, which we hope to be able to figure, and lay before our readers in the early future.

The plant, however, whose portrait we here lay before our subscribers, is the result of a cross between *Dendrobium Findlayanum* and *D. aureum*, and is at once beautifully chaste and very distinct. The plant was fertilised in the collection of Oscar Schneider, Esq., of Fallowfield, Manchester, and the seedlings were raised by Mr. Holmes, gardener to C. Moseley, Esq., at Grangethorpe, Rusholme, Manchester, and it is through the kindness of Baron Schröder, The Dell, Staines, that we have been afforded the opportunity of laying its beauties before our readers.

Dendrobium Schneiderianum is a plant having much the character and appearance of its first-named parent, *D. Findlayanum*, in habit of growth, and its flowers are large and showy, mostly produced in pairs on long pedicels; the sepals and petals are sub-equal, having the ground colour creamy white, tipped with rosy purple; the lip is half-rounded at the base, with an acuminate point, which is also rosy purple, behind which is a white zone; the base of the lip is downy, rich orange-yellow, bearing numerous veins and streaks of orange or purple. The plant is deciduous in habit, losing all its leaves before flowering, but so freely are the blooms produced, that one does not appear to notice the deficiency. The plant appears to be somewhat strong in constitution, and will doubtless become stronger as it increases in age. It should be planted in good peat fibre and sphagnum moss, using some moderate-sized nodules of charcoal to keep the whole open and free; this soil requires to be made firm, and the drainage must be perfect. We have found it to thrive best when treated as a basket plant, and hung up near the glass. During the growing season it requires an ample supply of water to its roots, and moisture in the atmosphere, but after the pseudobulbs are mature, and the leaves begin to fall, less heat and less water will be necessary, indeed, very little water should be given during winter. At the latter part of winter or early in spring, the plants should be watched for the pushing out of the flowers, and upon these becoming visible, gentle waterings should be given, and the temperature in which the plant was wintered may be raised a few degrees.



ODONTOGLOSSUM BLEUANUM SPLENDENS

MILTONIA (ODONTOGLOSSUM) BLEUANA SPLENDENS.

[PLATE 412.]

Garden Hybrid.

Epiphytal. The result of a cross between *Miltonia vexillaria* and *M. Roezlii*, having small ovate pseudobulbs, and linear-lanceolate acuminate leaves, which are soft green on the upper side, paler beneath. *Scape* erect, three to five flowered. *Flowers* large, but as the lip is not so disproportionate as in *M. vexillaria*, the flowers are rounder; *sepals* and *petals* oblong-ovate, broader than those of either of its parents, the former white faintly tinged with rose, petals broader than the sepals, and more obtuse, same colour as the sepals in the upper part, but having the lower half stained with a large blotch of lively rose; *lip* shortly clawed at the base, obcordate, trilobed in front, but in a less degree than that of *M. vexillaria*, and having a small mucro in the notch similar to *M. Roezlii*, ground colour creamy white, not pearly white; on the disc the ground is pale yellow, over which is spread a large blotch of soft chocolate-brown, which extends forwards in rayed streaks. *Column* short, raised up.

MILTONIA BLEUANA SPLENDENS, *Bleu, M.S.*

MILTONIA BLEUANA, *Linden and Rodigas in Lindenia, iv., t. 176.*

MILTONIA BLEUI, *Godefroy, L'Orchidophile, February, 1889, p. 45.*

MILTONIOPSIS BLEUI, *Godefroy, L'Orchidophile (with figure), May, 1889, p. 145.*

In this beautiful variety we have probably the first artificial hybrid *Miltonia* produced in the gardens of Europe which has flowered, and its great beauty will doubtless stimulate the hybridisers and cross-breeders of these plants to fresh exertions. This plant is due to the energy and skill of Mons. A. Bleu, of Paris, to whom we are already indebted for many excellent hybrid Orchids. It is the result of a cross between *Miltonia vexillaria* and *M. Roezlii*, and it combines the beauties of both parents. It is curious that so little has been achieved with this genus and its near ally *Odontoglossum*, for we have observed that in the case of seedling *O. Uro-Skinneri* that the plants grow freely, and we therefore cannot account for the tardy appearance of hybrid forms in our gardens; even the beautiful plant, whose portrait is now before us, opened its flowers just four years and nine months from the time of its being crossed, so that in this case the plants appear to come on very quickly. Of supposed natural hybrid forms of *Odontoglossums* from their native country we already have quite a host in our collections, and for this reason care will be necessary in naming our own seedlings, in order to avoid clashing with names

already in existence. It has been said that this plant can never be introduced, but it is just possible that in those districts where the two species from whence this variety was obtained approach each other, hybridisation by natural means may take place. For the opportunity of figuring this beautiful hybrid we are indebted to the kindness and liberality of Mons. Alfred Bleu, Paris.

Miltonia Bleuana splendens has pseudobulbs and leaves very similar to those of *M. vexillaria*, the flowers partaking of the mixed character of both species. The sepals and petals are broader than those of *M. vexillaria*, and the petals at the base are stained with violet or violet-rose, and the markings below the disc are a beautiful soft brown. It appears to be a plant of good robust constitution, very floriferous, producing its flowers in quite a young state. The flowers also are said to emit a peculiar grateful odour, between that of Mignonette and Lily of the Valley, but of this we have found no trace. It is an evergreen plant, and requires a house nearly as warm as the *Cattleya* house to winter in, and a certain amount of moisture is necessary to keep away thrips and red-spider. The pots should be thoroughly well drained, and the soil used should be a mixture of good peat, fibre, and sphagnum moss, the surface being wholly sphagnum; in fact it requires exactly the same treatment as do *M. vexillaria* and *M. Roezlii*, its two parents. This hybrid variety, if grown in quantity, will have a beautiful effect, especially if judiciously arranged with its two parent plants, and some other near relatives.



LÆLIA ELEGANS BROMÆANA

E. J. Wiland Sculp.

LÆLIA ELEGANS BROOMEANA.

[PLATE 413.]

Native of Santa Catherina, Southern Brazil.

Epiphytal. *Rhizome* stout, clinging tightly to the stems and branches of trees, and bearing at short intervals erect stem-like pseudobulbs, which are smooth and terete when young, becoming ribbed with age, smaller at the base, from one to two feet in height, bearing on the apex a pair of narrow oblong obtuse leaves, which are from nine inches to a foot in length, thick and leathery in texture, and deep green. *Peduncle* erect, robust, issuing from a large compressed sheath, and bearing from three to seven or more flowers, which measure some six inches across. *Sepals* and *petals* spreading, the sepals oblong-lanceolate, with plain edges, petals much broader than the sepals, obovate and lanceolate, with undulated edges, all of an intense rich purple, slightly paler towards the base; *lip* three-lobed, the basal lobes convolute creamy white, the tips reflexed, and heavily marked with rich maroon; anterior lobe large and flat, transversely oblong, prettily undulated, deep velvety maroon, throat creamy white, streaked with maroon. *Column* triquetre, enclosed, white, lightly marked with purplish maroon.

LÆLIA ELEGANS BROOMEANA, *O'Brien, Gardeners' Chronicle*, v., viii., 3 s., p. 214; *Gower, The Garden*, v. xxxviii., p. 158.

The variety of *Lælia elegans* we here figure is one of a batch introduced a few years ago, and of which previously but a few examples existed in our collections. Of these *L. Turneri*, figured in Warner's *Select Orchidaceous Plants*, i., t. 12, still remains amongst the rarest, best, and deepest coloured forms. Two varieties of these dark-flowered *elegans* we have already figured in the pages of this work, *i.e.*, *L. elegans prasiata*, t. 97, which flowered in the collection of Baron Schröder, at The Dell, Egham, and *L. elegans Morreniana*, t. 331, the latter being a finer one, which flowered in our own collection in the Victoria and Paradise Nurseries, Upper Holloway, and which we think was equal in beauty to the variety we now figure, although it differed somewhat in the colour of its sepals and petals. Nearly all the dark flowered forms of *L. elegans* appear to be autumn bloomers, and a short time since were to be seen in excellent condition in the collection of R. H. Measures, Esq., The Woodlands, Streatham, where many varieties of this beautiful species are congregated, some of them being exceptionally beautiful. Amongst the most striking forms we noted were *L. elegans Tautziana*, *L. e. tenebrosa*, *L. e. Minerva*, *L. e. melanochætes*, *L. e. Morreniana*, and *L. e. incantans*. Another form which was sent us last year, *L. elegans Mossiæ*, was superbly beautiful, and these, together with the present variety, form a magnificent group, worthy of all praise. For the opportunity of

figuring this beautiful variety we are indebted to the kindness of J. Broome, Esq., Sunny Hill, Llandudno, in whose collection it flowered for the first time in the month of July, 1889, and we have again recently received flowers from the same garden in Wales.

Lælia elegans Broomeana, like all the varieties of this species, is an evergreen plant, with a robust constitution, producing stem-like pseudobulbs some eighteen inches to two feet in height, bearing a pair of leaves, thick and leathery in texture, and deep green in colour. The growth when mature forms its sheath on the top of the bulb, and produces its spike, which bears numerous flowers of a large size; these are strikingly beautiful, and delicately fragrant. The sepals and petals are rich deep purple in colour, becoming paler at the base, and bearing a few darker spots; lip in the front lobe deep velvety maroon, the side lobes, which are rolled over the column, being creamy white, tipped with rich maroon. It blooms during the months of July and August. The typical *L. elegans*, and all its varieties, enjoy an abundance of heat during the growing season; indeed, it will scarcely be possible to put them in too strong a heat, provided the hottest rays of the sun are kept from them, for although we have found these plants to enjoy full exposure to the light, they yet require shading from the full solar heat. During the growing season an abundance of humidity in the atmosphere, and a fair amount of water to their roots is also necessary, and therefore good drainage is absolutely essential to their well being. After flowering time, which is their season of rest, very little water will suffice, the temperature must be reduced, and only sufficient water given the roots to prevent shrivelling in any part of the plant. They grow naturally upon the stems and branches of trees, but under cultivation we find them thrive best under pot culture, using for soil, good peat fibre (from which all the fine part has been shaken), a little chopped sphagnum moss, and some medium-sized nodules of charcoal; the whole should be built up into a cone-like mound above the pot's rim, and be made very firm; this cannot be done if pieces of charcoal of too large a size are introduced. Nothing is more injurious to a plant than to be so potted, that the slightest movement causes it to rock about, straining the roots, and oftentimes breaking them entirely.



J. Nugent Fitch del. et lith.

B.S. Williams & Son, Publrs

ODONTOGLOSSUM ALEXANDRÆ PLUMATUM.

ODONTOGLOSSUM CRISPUM (ALEXANDRÆ) PLUMATUM.

[PLATE 414.]

Native of the United States of Colombia.

Epiphytal. *Pseudobulbs* ovate, compressed, bearing several sheathing leaves from the base of the pseudobulbs; these, however, are not persistent, but usually die away annually. The persistent leaves are developed from the apex of the pseudobulbs, mostly in pairs; they are oblong-lanceolate in shape, acute, and rich deep green in colour. *Scape* radical, erect, bearing a raceme of many flowers, which are upwards of three inches across, spreading and very showy. *Sepals* ovate-lanceolate, acute, with plain edges, white, suffused with soft rose, and freely dotted and spotted with rich bright cinnamon; *petals* ovate, much broader than the sepals, dentate and undulate on the edges, so much so, as to produce quite a plumose effect, same colour as the sepals, but with fewer spots; *lip* oblong, truncately rounded at the point and cuspidate, having the margin much toothed and fringed, white, tinged with rose, and dotted with cinnamon. *Crest* yellow, rayed, the *column* bearing on either side, the toothed wings so conspicuous in the typical plant.

ODONTOGLOSSUM CRISPUM (ALEXANDRÆ) PLUMATUM, *supra*.

This is an exceedingly beautiful variety of a very popular plant, and it is quite astonishing to see the numerous distinct and pretty forms which may be obtained from an unflowered batch of this species, particularly if the plants have been collected in any well-known district. There would appear, however, to be some doubts as to the possibilities of getting this species in any great quantities at the present time, for collectors tell us that the localities which a few years ago abounded with *Odontoglossum crispum* (*Alexandræ*), at the present moment are so exhausted, that the species cannot be collected there profitably. If such is the result of reckless importations, our growers should be more sedulous in keeping and preserving the plant when it is brought home, and thus prevent many hundreds of plants being needlessly wrenched from the trees in their native forests, and the country exhausted of its treasures. The variety here figured flowered with us in the Victoria and Paradise Nurseries, in the month of June in the present year. It was specially noted by many visitors, and became quite a marked feature in the *Odontoglossum* house, and we trust to again flower it in greater profusion another season.

Odontoglossum crispum (*Alexandræ*) *plumatum*, as its name implies, is a plant which when in flower has markings on its petals of quite a feathery character. It produces fine spikes of flowers, which are very effective, and it lasts many

weeks in full beauty; indeed, it appears to be quite impossible to find any situation its flowers do not brighten by its presence. *O. crispum* (*Alexandræ*) and its varieties may be used in any position where flowers are required, either in a cut state, or when growing upon the plant. In the latter state, on account of the cool treatment necessary for their maintenance, they may be used on the dinner table, or in a lady's boudoir, with equal taste and *eclât*. It is a dwarf-growing compact plant, free in habit both in growing and flowering, and we certainly are quite at a loss to understand why it is that anyone having a cool house, does not succeed with *Odontoglossums*. This plant, like many of its class, requires to be potted in good fibrous peat; the pots must be well drained, in order to quickly carry away the surplus water which will be given it, to cause a humidity in the atmosphere, and the surface should be clothed with sphagnum moss. This latter material should be kept in a growing state, which if it does well, will require clipping occasionally, to keep it neat in appearance. If this does not come about, the water should be carefully examined, for if lime is found in the water its use must be discontinued, although it may still be used for damping floors and stages. Lime in the water will soon kill the growth of the moss, and should therefore be avoided.



J. N. Poir. del. et lith.

BRASSAVOLA GLAUCA.

J. S. Williams & Son. Lith.

BRASSAVOLA GLAUCA.

[PLATE 416.]

Native of Mexico and Guatemala.

Epiphytal. *Pseudobulbs* produced from a stout creeping rhizome, these are some four inches in length, compressed, bearing a single oblong, obtuse leaf on the summit, which is thick and leathery in texture, very glaucous, and from three to six inches in length. *Peduncle* erect, about as long as the leaf, issuing from a small compressed sheath on the top of the pseudobulb, and bearing a single large flower, which is delicately fragrant. *Flowers* three to four inches across; *sepals* and *petals* nearly equal, lanceolate in outline, and obtuse, of a soft pale green hue; *lip* cordate, acute, waved at the edges, white, marked in the throat in some instances with lines of pinkish lilac. *Column* short and stout.

BRASSAVOLA GLAUCA, *Bateman, Orchids of Mexico and Guatemala*, t. 16; *Botanical Register*, 1840, t. 44; *Botanical Magazine*, t. 4033; *Hooker's Century of Orchids*, t. 22; *Williams' Orchid Grower's Manual*, 6th ed., p. 149.

BLETIA GLAUCA, *Reichenbach fil., Xenia Orchidaceæ* ii., p. 50.

LÆLIA GLAUCA, *Bentham et Hooker, Genera Plantarum*, iii., p. 534.

This is one of the old Orchids in English gardens, having been first introduced by Hartweg from Xalapa upwards of fifty years ago, and subsequently it was found in Guatemala by Mr. Skinner growing upon oak trees in company with other Orchids. It is a plant which has never become popular with the majority of English Orchid-growers, probably through lack of colour in its flowers, but it has frequently been found to exist in collections where it had never been known to bloom, and this, probably, more through neglect than from any other cause; indeed, we flower the plant annually, and therefore cannot accept the dictum that it is difficult to bloom, provided the plant is kept in good health, and is sufficiently strong to produce flowers. There is, moreover, a reason why the growth of this plant should be encouraged, flowering as it does in the months of February and March: it becomes an excellent subject for cross-breeding, and for those having any enthusiasm on this subject, should be seized upon with avidity; indeed, we persuaded Mr. Osborne, when in the service of H. J. Buchan, Esq., of Southampton, to cross *Sophronitis grandiflora* with this plant, which was done, and the plants are, we believe, growing from these seeds. This, we imagine, should produce a showy and popular flower. The specimen from which our plate was produced was one grown in our own collection in the Victoria and Paradise

Nurseries, Upper Holloway, and which flowered in February of the present season, the same plant having bloomed annually for several years in succession.

Brassavola glauca is a compact-growing, robust and hardy evergreen plant, both the pseudobulbs and leaves being of a very glaucous hue, and the latter are very persistent. Its rhizome is stout and creeping, and its pseudobulbs short and numerous, the leaves being very coriaceous in texture.* The flowers are produced singly upon a short pedicel, which rises from the top of the pseudobulb; these are large and spreading, and deliciously sweet, this being particularly apparent towards the evening. The sepals and petals are spreading, nearly equal, obtuse, lanceolate, plain at the edges, and pale green with a few darker lines and streaks; lip heart-shaped, rolled round the column at its base, the front portion expanded, more or less lobed at the edges, but entirely destitute of the fringe which is such a conspicuous object in its near ally, *B. Digbyana*, figured in this work at plate 241. The whole is creamy white, more or less streaked in its throat with pinkish lilac. This plant in its young stages is best grown upon a block of wood or in a basket; if the latter, we prefer the shallow earthenware kind to those made of teak-wood, as the soil can be made firmer; and for Orchids especially young or small plants, this is a feature which cannot be too strongly impressed upon the minds of our readers. As the plant becomes larger and stronger it may with propriety be removed into a pot, and grown with other plants similarly situated, the temperature best suited to it being the Cattleya-house. During the resting season, after its growth is finished, we have found it thrive well at the warm end of the Odontoglossum-house, and the moisture of the atmosphere in this situation will be found almost sufficient for its wants.



PHALÆNOPSIS BRYMERIANA.

PHALÆNOPSIS INTERMEDIA BRYMERIANA.

[PLATE 415.]

Native of the Philippine Islands.

Epiphytal. Stemless, bearing distichous ligulate leaves of an oblong-ovate form, thick and fleshy in texture, and rich green on the upper side, pale green beneath. In some forms the leaves are quite oblong, and bear transverse streaks of silvery grey over the upper side, plainly showing a Schillerianian origin, but these white streaks fade out with age. *Raceme* axillary, gracefully arched, and bearing many flowers, which are quite intermediate in size between *P. Schilleriana* and *P. rosea*. *Sepals* and *petals* spreading, of good substance, the sepals oblong acute, petals much broader than the sepals, rhomboid, acute, all white, tinged with rosy lilac, the lateral sepals frequently dotted with magenta, the lateral ones incurved, somewhat cuneate, obtuse, white flushed and freckled with magenta, anterior lobe ovate, bi-cirrhone at the apex; at the base of these cirrhi is a little fleshy ridge, the whole front lobe being coloured soft amethystine-purple, stained with yellow on the basal edge, the fleshy crest at the junction of the lobes depressed in the centre, yellow, freckled with deep red. *Column* soft rosy purple.

PHALÆNOPSIS INTERMEDIA BRYMERIANA, *Reichenbach fil.*, in *Gardeners' Chronicle*, N.S., 1876, p. 366; *Floral Magazine*, Second Series, t. 263; *Williams' Orchid-Grower's Manual*, 6 ed., p. 531.

In the year 1837 Hugh Cuming sent the Messrs. Rollisson, of Tooting, some plants which Lindley named *Phalænopsis amabilis*, the Queen of Orchids, and it was the first species ever introduced to Europe. Some ten years later Mr. H. Schröder, of Stratford Green, exhibited a plant before the Horticultural Society, not knowing it to be distinct from *P. amabilis*, but Dr. Lindley pointed out its differences in the *Gardeners' Chronicle* the next season, and in its pages on January 15th, 1848, p. 39, will be found figures of these new plants, and with descriptions of the two species, the last named being *P. grandiflora*. Since this date, from time to time, we received a new species of *Phalænopsis*, and at last the grand *P. Schilleriana*, was introduced to English gardens by the then head of our firm, (Mr. B. S. Williams), and a figure of the plant formed plate 1 of Warner's *Select Orchidaceous Plants*. Since this time the number of species and varieties have increased vastly, so that to have a full collection of all the *Phalænopsis* known would occupy a goodly space, and since we came by the knowledge of *P. Schilleriana* we have been made acquainted with numbers of forms, which lead one to suppose that many happy marriages have taken place between it and other kindred species. The plant of which we now produce a likeness in this place is a supposed result of a cross between *P. amabilis* and *P. rosea*, but from the faint silvery grey

markings in the leaves in some forms *P. Schilleriana* would appear to us to have taken the place of *P. amabilis*. The plant from which our artist obtained the materials for this plate, came from the gardens of the late G. Frith, Esq., Manninghamthorpe, Bradford, where, under the care of Mr. Collier, Phalænopsids of all kinds were well and largely grown. This plant first flowered in the collection of W. E. Brymer, Esq., M.P., Ilsington House, Dorchester, and after whom Professor Reichenbach worthily named it. The flowers in shape are exactly similar to those of *Phalænopsis intermedia* of Lindley, but as a variety it is abundantly distinct, and its leaves, when young, being streaked with silvery grey, would imply a different parentage to *P. intermedia Portei*, which it has been suggested is *P. amabilis* and *P. rosea*; the intermediate characters, we should imagine here being produced by *P. Schilleriana* and *P. rosea*. Our artist has so well defined the colours and general habit of the plant, that one scarcely need attempt the fruitless task of painting the lily.

Phalænopsids are not so largely grown or so much sought after by the present race of Orchid growers as they were by their predecessors, and in consequence are not so popular. The reason for thus ignoring the beauties of these lovely plants is the supposed difficulty in growing them, but any one who had the opportunity of inspecting the wonderful collection of Phalænopsis gathered together in the gardens of the late Mr. Partington, at Cheshunt, could not but believe in their beauty and magnificence, and also be impressed with the ease with which they were managed by Mr. Searing, the gardener. The chief methods we noted in Mr. Searing's treatment of these grand plants under his charge, in the first place, was an abundant supply of fresh air, and to this end we anticipate the system recently brought into use by Mr. Toope, of Stepney, will be specially valuable, as supplying a long-felt want, *i.e.*, of providing a continual current of fresh, pure air, without the slightest draught. Another important factor in Mr. Searing's management of these plants, was in keeping the roots free from contact with soil, and in supplying moisture to the roots by evaporation.

Phalænopsids are all eastern plants, the great majority of the kinds coming from the islands of the Indian seas, but some few kinds are found upon the Indian mainland, and all in places where the temperature is high, therefore they should be grown in a temperature of from 70° to 80° or more from the month of March until the beginning or the middle of October. During this time, while exposing them to as much light as possible, they must be shaded from the burning rays of the sun. During the remaining part of the year the temperature may be allowed to fall to about 60° or 65° by night, rising about 5° by fire-heat during the day, and if the sun obtains power it may be allowed to raise the heat much more without any injurious effects arising. Of course during this, their resting season, much less humidity must be maintained in the atmosphere, but as these plants have neither pseudobulbs nor stems, they can never at any season be allowed to become dry without injury. A very small amount of living sphagnum moss may be placed round about them, but this must be kept in a growing condition, as immediately decay sets in it should be removed.



ODONTOGLOSSUM URO-SKINNERI.

[PLATE 417.]

Native of Solola, Guatemala.

Terrestrial. *Pseudobulbs* large and ovoid, compressed, and attached to a running rhizome, light green, spotted with purple on the basal portion. *Leaves* ovate, lanceolate, nine inches to a foot long, broad and recurved, dark green on the upper side, paler beneath, where they are carinate. *Scape* erect, from two to three feet high, sometimes branching, and many-flowered, the individual blooms from two to three inches across, and perfumed with the fragrance of honey. *Sepals* and *petals* sub-equal, oblong, acute, usually green, thickly spotted with dull brown, but in the present instance a rich deep chestnut-brown, with numerous green tessellations; *lip* broadly cordate, clawed at the base, undulated, rich bright rose, netted with white, with spotted lines of dark rose, and bearing two thin fleshy plates on the claw. *Column* winged.

ODONTOGLOSSUM URO-SKINNERI, *Lindley in Gardeners' Chronicle*, 1859, pp. 708, 724; *Bateman's Monograph of Odontoglossum*, t. 2; *Warner's Select Orchidaceous Plants*, Third Series, t. 17; *Lindenia*, iii., t. 122; *Veitch's Manual of Orchidaceous Plants*, part i., p. 69 (with woodcut); *Williams' Orchid-Grower's Manual*, 6 ed., p. 466.

The typical species was found by Mr. George Ure Skinner, whose name it commemorates, near the village of Santa Catarina, in the district of Solola, which is nearly a hundred miles distant from the City of Guatemala; but the plant here figured is a much finer variety than the one taken for illustration by Mr. Bateman in his Monograph of the genus *Odontoglossum*; indeed, we cannot but think that the appellation of *splendens* is really deserved by this variety. It would seem that the plant first flowered in the establishment of Messrs. Veitch & Sons, of Chelsea, about the year 1859, and some discussion took place about its being a hybrid; but Mr. Skinner was strongly opposed to this theory, and he writes thus:—"I may be allowed to satisfy you that this is no hybrid, it is a very distinct species which I found growing on rocks near the village of Santa Catarina," and he further adds, "it proves a very bad plant to get over alive, but in several attempts a few survived." We suspect, however, that in the days when Mr. Skinner wrote these lines the means of transit were much slower than at the present time, and the style of packing was not so well understood as it is to-day; there is consequently far less risk than formerly in the transit to England. We wish some one would put this to the test now, in the case of *Odontoglossum Uro-Skinneri*, as the plant is becoming somewhat scarce in cultivation. It is a noble, large-growing kind, and we have seen it growing luxuriantly in the collection of H. J. Buchan, Esq., Wilton House, Southampton;

here, too, we saw the first seedling *Odontoglossums* which had been raised in this country; they had been obtained from this species without any efforts at hybridisation, and were growing and doing well.

The grand variety here figured was grown in the fine collection of E. Salt, Esq., Ferniehurst, Shipley, Leeds, and is another fine record to add to the many superb varieties which have flowered in that establishment, and we are much indebted to him for the opportunity of figuring it in the pages of the ALBUM. It blooms in the autumn months, and lasts a long time in full beauty.

Odontoglossum Uro-Skinneri is a bold-growing evergreen plant, making large flat pseudobulbs, which spring from a creeping rhizome. The leaves are ovate-lanceolate, firm, and of good substance; the ground colour of the sepals and petals is very variable—indeed, this has been noted from the time of its first introduction. Mr. Skinner said of it “that it varied in almost every plant”; but although during the past thirty years we have seen many plants in flower, not one to approach the beauty of the one here figured has appeared. The colouring of the sepals and petals is for the most part of a pale green, marked over the surface with brown blotches, or of a dull brown, mottled more or less with green, and the lip white, dotted all over with blue or pale rose, with white markings, and not the rich rose and chestnut-brown of this illustration. The present plant is evidently a near ally of *O. bicktonense*, but Mr. Skinner points out the difference in the two species. He says, “*O. bicktonense* has oblong narrow bulbs and leaves, and no rhizome, but massed and always terrestrial, half buried in mossy banks.” Our present plant has large and flat bulbs and a running rhizome; but we think that the conditions under which Mr. Skinner found it, *i.e.*, on rocks, are too often lost sight of by our Orchid growers. We have frequently observed this plant to be very much over-potted, and in consequence, thriving indifferently; therefore, bear in mind our advice and do not overburden the roots with soil, which is the great stumbling-block, especially to young amateur growers. Drain the pots carefully and well, and use for soil about half good peat fibre, from which all the fine mould has been well shaken, and some chopped sphagnum moss; mix the whole together with some medium-sized nodules of charcoal, and in potting add here and there a slight dash of sharp, gritty silver sand, pressing the whole down very firmly. At this, the dull season of the year, water sparingly, but keep the plant moist, and at the turn of the season, when the days lengthen and the sun brightens, more may be given, until in the summer season it may be treated in the same manner as the beautiful *O. crispum* (*Alexandrae*), which we all love so well.



CYPRIPEDIUM MARSHALLIANUM.

CYPRIPEDIUM MARSHALLIANUM.

[PLATE 418.]

Garden Hybrid.

Terrestrial. *Leaves* distichous, broadly oblong, obtuse, ground colour light green, mottled with very deep green on the upper side, dull purple beneath, about six inches long. *Dorsal sepals* large, broadly ovate, incurved towards the apex, ground colour white, faintly suffused with rosy purple over the entire surface, and faintly tinged with yellow towards the base, the veins densely dotted with purple; *lower sepal* smaller, creamy white, dotted in a less degree with purple; *petals* deflexed, broadly obtuse, coloured and dotted in a similar manner to the dorsal sepal; lip pale yellow, tinged with light green, flushed and dotted with purple on the upper part about the aperture, the interior pale yellow, dotted with purple. *Staminode* yellow, tinged with green, with a purple tinge in the centre.

CYPRIPEDIUM MARSHALLIANUM, *Reichenbach fil, Gardeners' Chronicle*, 1875, iv., n.s., p. 804; *Veitch's Manual of Orchidaceous Plants*, iv., p. 91.

This beautiful Veitchian hybrid has been in existence for many years, but such a slow grower is it, that for a long time the only plant that existed was in the rich collection of Slipper Orchids in the possession of F. G. Tautz, Esq., late of Studley House, Shepherd's Bush. Since then, however, the plant from which our drawing was taken has changed hands, and it is now in America, but one small plant only is, we believe, still in this country, and that is in The Woodlands collection, at Streatham. It is the result of a cross between *Cypripedium venustum* or *C. venustum pardinum* and *C. concolor*. It was for a long time a unique variety, but now we are in possession of one or two others, such as *C. Vipanii*, *C. Aylingii*, and *C. Arnoldianum*, with a similar contour, which robs the present plant of some of its charms for novelty, although they do not excel this for chaste delicacy. The great fault with this variety is its slow growth, but we suppose all hybrids having *C. concolor* or any of this section for parents will always be open to that complaint. One thing is certain, and that is, they cannot endure cutting, and great care is requisite in handling them, to do as little with the knife as possible. The plant here portrayed was grown as before stated in Mr. Tautz's fine collection, where everything was smart and clean before it was dispersed, and well cared for by Mr. Cowley, his gardener, who has obtained many promising seedlings, and hope that they will prove, on flowering, desirable acquisitions to this fine class of plants, and will make the new home of Mr. Tautz celebrated.

Cypripedium Marshallianum is a pretty plant; by its foliage it suggests to the mind at once that *C. venustum* was one of its parents. It is an old cross of the

Messrs. Veitch and Sons, and we learn that upon its first opening its flowers in their establishment little notice was taken of it, as it was not supposed to be of much value; but we cannot but think the flowers were not developed so well as these here depicted, for when we saw this plant in bloom, it seemed to us that it was a gem of the first water. As before remarked, *C. Marshallianum* is very slow in growth, a peculiar trait in all the hybrids belonging to the *concolor* group, that is, having this species for one of their parents. *C. concolor* is widely distributed, and appears always in the limestone formation, so that this should be taken into consideration both with it and any of its hybrids. We advise the drainage to be composed of small nodules of lime-stone, also some should be mixed with the soil in potting. Want of this material has probably been the cause of the slow growth of its hybrid *C. Marshallianum*. For soil use peat fibre and sphagnum moss, in about equal proportions, pressing the whole down firmly, and raising the plant above the rim of the pot but slightly. Water must be freely given, and therefore the drainage must be exceptionally good, in order to carry off any surplus quickly, thus preventing stagnation in any form. It is a plant that enjoys a warm moist atmosphere, and should therefore be treated to a liberal amount of light, heat and moisture, and we are under the impression that it delights in a humid atmosphere the entire season.



DENDROBIUM CHRYSOTIS.

DENDROBIUM CHRYSOTIS.

[PLATE 419.]

Native of Sikkim and Assam.

Epiphytal. *Stems* erect, slender, tufted, somewhat swollen at the base, from two to six feet high, green tinged with purple. *Leaves* distichous, alternate, oblong-lanceolate, acuminate, from three to six inches long, and deep green. *Racemes* axillary, issuing from the stem at the opposite side to the leaves, pendent, borne on the leafy stems, and from six to nine flowered, each flower measuring from three to four inches across. *Sepals* and *petals* spreading, oblong acute, entire, nearly equal in size, and uniform in colour, which is rich golden yellow; *lip* almost cordate, deeply bordered round the edge with a thick bearded fringe nearly half an inch in length, the surface being velvety and the ground colour more of an apricot hue than the petals, whilst at the base of the lip are two large flaked spots of deep velvety-purple. *Column* short, white.

DENDROBIUM CHRYSOTIS, *Reichenbach fil.*, *Gardeners' Chronicle*, 1870, p. 1311; *Warner's Select Orchidaceous Plants*, iii., t. 6; *Florist and Pomologist*, 1871, p. 145; *Illustration Horticole*, 1873, 3 series, t. 155; *Williams' Orchid-Grower's Manual*, 6 ed., p. 274.

DENDROBIUM HOOKERIANUM, *Lindley*, *Journal of the Linnaean Society*, iii., p. 8; *Botanical Magazine*, t. 6013; *Reichenbach*, *Gardeners' Chronicle*, ii., s. 3, 1887, p. 616.

This is a grand and free-flowering species of *Dendrobium*, belonging to a section which is well represented by the better known *D. fimbriatum oculatum*, and of which it is a near ally. It was first discovered in Sikkim, in 1848, by Dr. Hooker (now Sir Joseph Hooker) whilst collecting seeds of the Rhododendrons of that district, and for which his name has become famous throughout the world; but to the late Mr. John Day is due the credit of its introduction in a living state to this country, through his nephew, Captain Williamson, who sent it from Assam; and Dr. Hooker says, "It is stated to come from Assam, which is very probable, as I discovered it in the neighbouring province of Sikkim growing on trees in a hot valley, at an elevation of 1—5,000 feet above the sea." It flowered for the first time in Europe with the Messrs. Brooks, of Manchester, in 1870, and was exhibited before the Royal Horticultural Society in September of that year, when it was deservedly awarded a First Class Certificate. In the summer of the following year (1871) we imported a large quantity of this species from Assam, with strong, robust, rod-like stems, some five and six feet high, many of which flowered in our establishment, and proved extra fine varieties; but in spite of the numbers distributed from the Victoria and Paradise Nurseries and elsewhere, the species

never seems to have become popular, although in spite of the many new kinds introduced since that time it still remains one of the very handsomest of the autumn-flowering kinds, whilst from the fact of its blooming on the leafy stems its beauty is considerably increased; this is quite a marked distinction between it and its near ally, *D. fimbriatum oculatum*, whose flowers always spring from a leafless stem, independent of the size of the flower and the greater depth of the mossy fringe of the lip, and sundry other distinctions of a more botanical description. The plant we here figure was grown in the grand collection of Sir Trevor Lawrence, Bart., M.P., at Burford Lodge, Dorking.

Dendrobium chrysotis is a very free-growing plant, and why it has never become popular is marvellous, as its flowers are produced abundantly on pendent spikes, six to nine being borne on each raceme, the flowers measuring nearly four inches across, and these vary in colour from rich golden yellow to a beautiful apricot-yellow, the lip in addition having two large velvety dark purple spots at its base, and a very deep mossy fringe on the edge. This plant has been seen with considerably over two hundred flowers, and in such a state must be extremely ornamental. It blooms in the autumn months, and lasts about a fortnight or three weeks in perfection. There is little or no difficulty in growing this plant into a good specimen, heat and moisture during the growing season being the two essentials. From its stature it naturally thrives best under pot culture, and the pots require to be well and thoroughly drained, because, although the plant likes a copious supply of water to its roots during the growing season, this must be conveyed away quickly; indeed, we know of no plant with such an apparently robust constitution that is so easily affected by stagnation of the water and old and sour soil; therefore, drain well, and let everything be sweet and clean about it. For soil, use peat fibre and sphagnum moss in about the proportion of two parts of the former to one of the latter, with a fair admixture of small nodules of charcoal, the whole to be pressed down firmly and built into a cone-like mound above the rim of the pot. In the winter it may be kept cool, that is to say, a temperature of between 55° and 60° will suit it well, but in the summer months it enjoys plenty of heat and moisture.



CYPRIPEDIUM ACALE SUPERBUM

CYPRIPEDIUM CENANTHUM SUPERBUM.

[PLATE 420.]

Garden Hybrid.

Terrestrial. Stemless. *Leaves* distichous, ligulate, and deep green, faintly tessellated. *Scape* erect, clothed with a tomentum of dark purplish hairs, and bearing a single large and highly-coloured flower on the apex. *Dorsal sepal* deep vinous red at the base, and in the centre, through which run numerous spotted lines of rosy purple, the margins and upper portion passing into bright purplish mauve, the outer margin white; *lower sepal* greenish white, spotted on the veins with blackish purple; *petals* deep yellowish brown, darkest on the upper half; *lip* large, broadly obtuse, rich deep port-wine colour on the exterior, yellowish within, freely dotted with reddish purple. Its parents are *Cypripedium Harrisianum* and *C. insigne Maulei*.

CYPRIPEDIUM CENANTHUM SUPERBUM, *Veitch's Catalogue*, 1885, p. 11; *Reichenbachia*, First Series, i., t. 38; *Lindenia*, i., t., 33; *Revue de l'Horticulture Belge*, 1885, p. 233; *Veitch's Manual of Orchidaceous Plants*, iv., p. 94, with woodcut.

The present beautiful plant is a Veitchian hybrid, of great beauty and richness of colouring. When speaking of *Cypripedium ceanthum* in the last volume, p. 379, we remarked that were we confined to grow one form of these Slipper Orchids, it would be this variety, on account of its freedom in flowering, and its bright and cheerful appearance; this variety only intensifies that feeling, for we cannot but feel that this plant is one of the very handsomest of the genus. There would appear to be several varieties of *C. ceanthum*, such as *Orestes*, *Electra*, *Acis*, and others, some of which are only supposed to be of this parentage, but the prevailing colours and markings prove them to be all from the same stock. At the present moment we say, without fear of contradiction, that no brighter and richer colours have yet been obtained than from the two parents of the present plant, *C. Harrisianum* and *C. insigne Maulei*. For the privilege of producing a figure of this superb variety, we are indebted to the kindness of R. H. Measures, Esq., of The Woodlands, Streatham, who has one of the most superb and complete collections of Cypripedes in this country. The plants are exceedingly well grown by his gardener, Mr. Abrahams, who appears to be nearly or quite as great an enthusiast for these Slipper Orchids as does Mr. Measures himself.

Cypripedium ceanthum superbum is an extremely handsome variety, presenting all the beauties of the original *C. ceanthum*, with the colours deepened, brightened, and intensified. The flowers, too, are larger, and the upper sepal is far more richly coloured, the intense deep vinous purple pervading the whole surface,

and running out in feathery streaks to the broad white marginal border. We have not seen this variety produce a two-flowered scape, although we have in the case of *C. aenanthum*, but many of the kinds which have hitherto been looked upon as single-flowered have produced two flowers, and if this character should be developed in this case, it would add greatly to the pleasure of the grower. The flowers appear at an unusually welcome time; and only the last month (October) when walking through the establishment of Mr. Measures, we saw several of these plants in flower then, and enlivening the scene with their presence. These plants are all grown at The Woodlands in the East India house, and we believe this is the best place for most of the species and hybrids from the eastern regions. In a cooler stove there are a fine lot of specimens of *C. insigne* and its varieties, which are now well in bloom, the same plants having been in flower for about seven months last season; in fact, one can never call at The Woodlands without seeing a fine lot of flowers of this genus alone.



CATTELYA MOSSIÆ DECORA . . .

CATTLEYA MOSSIÆ DECORA.

[PLATE 421.]

Native of La Guayra.

Epiphytal. *Pseudobulbs* and growth not differing from that of the typical plant. *Flowers* very large, being between seven and eight inches across; spreading and richly coloured; *sepals* lanceolate, somewhat narrow, entire at the margins, with recurved tips; *petals* much broader than the sepals, elliptic-ovate in outline, irregularly crisp and undulated on the margins, ground colour deep rich rose, the petals faintly streaked near the tips with crimson; *lip* broadly obovate, spreading in front, three-lobed; side lobes convolute over the column, and there coloured the same as the petals; the spreading front lobe is beautifully lobed and crenulated on the margin, emarginate in front, rich orange-yellow at the base, over which is spread a layer of deep crimson, passing into rosy lilac, with a soft rose-coloured marginal border. *Column* included.

CATTLEYA MOSSIÆ DECORA, *supra*.

In bringing this form of *Cattleya Mossiæ* before the notice of our readers, we are reminded that as a species it was one of the greatest favourites of the late head of our firm, our respected father, Mr. B. S. Williams. It is one of the largest of the *labiata* section, to which it belongs, and was named by Sir William Hooker in honour of Mrs. Moss, of Otterspool, Liverpool; at the present day we are told this collection is still in existence. We are under the impression that it was the first species of this section introduced after the genus was established, and it is one of the very handsomest of that set at the present day, whilst the varieties are innumerable. It appears to be a native of Venezuela, and to have a somewhat limited range of country; but the quantity in which it exists there has been described to us in glowing terms by Birschell, who travelled in Venezuela in 1855—6, and it was from the importation of *C. Mossiæ* brought home by him at that time that the *C. Wagenerii* first originated in English gardens. The plant here figured flowered in our collection in the Victoria and Paradise Nurseries, Upper Holloway, London, during the summer of 1890, and it has been designated *decora* from the exquisite gracefulness and beauty of its flowers.

Cattleya Mossiæ decora is an evergreen, compact-growing plant, and, like all the varieties of *C. Mossiæ*, very free flowering if properly grown and managed, a proper season of rest being essentially necessary to the proper development of good flowers. Under the old system of growing Cattleyas, an excessive heat was maintained, with very little ventilation and with drenchings of water, the latter

meant to imitate the annual rainfalls, which are excessive in their native countries; but this was found not to be tolerated under cultivation, and we now find the best system to adopt is to cease the drenchings of water, for with the present system of ventilation, even in the best constructed houses, air cannot be admitted in anything like the volume the plants are subjected to in a state of nature, and consequently the water does not dry up, but it lies about the plants and causes destruction to the young growths. Cattleyas are spread over a vast extent of territory, and need a variety of temperatures and conditions to suit them; but taking *C. Mossiæ*, which has a somewhat restricted range in the mountains of Venezuela, which lie near the coast, we can mete out its requirements pretty accurately, and the same conditions suit most of the group known as the *labiata* section. Naturally they grow upon trees and rocks, having little or no moss about their roots—nothing but a few fallen leaves of the trees upon which they grow, consequently they have nothing to rot or decompose their roots, and hence the necessity of good drainage is well exemplified. Growth upon blocks of wood would, therefore, appear to be the best style of growth under cultivation; but under artificial treatment we find sufficient moisture cannot be maintained, so that we are compelled to grow them in pots. These should be thoroughly drained, and some good fibrous peat, from which all the fine particles of soil have been beaten should be used. To this may be added a little chopped sphagnum moss, as it tends to bind the fibre better together, and the soil is best suited to the plants when firm and hard. The soil should be elevated an inch or two above the pot's rim, and upon this cone-like mound the plants should be placed. Do not over-pot, and do not re-pot too frequently, for this we consider is a great drawback to the successful growth of Cattleyas. During the summer season, which is their season of growth, water must be given cautiously. The roots will not require watering more than twice or thrice in the course of the week, but frequent waterings between the pots will be necessary, and also on the floor of the house, as great humidity in the air is absolutely necessary. When growth is completed, the watering must be discontinued gradually until the shoots are fully ripened and made up, and the watering between the pots and on the floor of the house may be entirely discontinued, saving only about once or twice in the week a little may be thrown about in order to prevent shrivelling; for we cannot believe it necessary to shrivel any plant to rest it in a legitimate manner. Ventilation should be free and ample, but it should be without draught; neither should there be any perceptible heating of the house after water has been poured down. Shading should be done without as much as possible in the cultivation of Cattleyas; but many people forget their plants are under glass, and are apt to become burnt with the sun. Thin shading should, however, be used, and it should not be allowed to cover the plants more than just during the few hours at midday. As the autumn comes on it must be borne in mind that *C. Mossiæ* sheaths have to stand until the following spring, and that in the event of premature growth the flowers may be prevented from coming. Care should, therefore, be taken, by keeping the plants cool and dry, that the growth does not become excited.





Engelm. Bot. del. et lith.

DIPODIUM PALUDOSUM.

B. S. Williams & Son. Lith.

DIPODIUM PALUDOSUM.

[PLATE 422.]

Native of Malacca, Borneo, and Cochin China.

Epiphytal. *Stem* slender, erect, producing roots at intervals. *Leaves* distichous, sheathing, ligulate, acute, thin in texture, and pale green or metallic green in colour. *Peduncle* axillary, erect, much longer than the leaves, furnished with a few small sheathing bracts, and bearing near the apex a raceme of from six to twelve flowers, measuring individually about an inch and a half across. *Sepals* and *petals* sub-equal, oblong-lanceolate, about an inch long, somewhat fleshy in texture, all of a soft creamy white, dotted with purplish magenta; *lip* cuneate-oblong, slightly thickened towards the base, and there ornamented with two prominent teeth, white, streaked and blotched with purple, downy along the centre, dentate on the margins. *Column* stout, white, passing into pale yellow upwards.

DIPODIUM PALUDOSUM, *Reichenbach fils, Xenia Orchidacea*, ii., p. 15; *Gardeners' Chronicle*, 1888, ii., p. 91.

GRAMMATOPHYLLUM PALUDOSUM, *Griffith, Notulæ*, iii., p. 344.

WAILESIA PALUDOSA, *Reichenbach fils, Bonplandia*, ii., p. 93.

We have some little diffidence in placing this plant in the genus *Dipodium* a genus established by Robert Brown, and which we are told includes a few leafless terrestrial plants, as with neither of these features does the plant here depicted agree; it certainly accords with the genus *Wailesia* of Lindley, established upon *W. picta*, also a native of Malacca, and with *W. paludosa*, as the plant now before us is described by Reichenbach; but more recent authorities have merged that genus with *Dipodium*. Be this right or wrong, however, we have to be satisfied with placing on record a good figure of this rare plant, and allow those learned in technicalities to decide the question.

The plant, whose portrait we now lay before our readers, flowered in our own collection in the Victoria and Paradise Nurseries, Upper Holloway, London, in July of last year, and was exhibited before the Committee of the Royal Horticultural Society; we believe it was the first appearance of its flowers in European gardens. It was originally found by Griffith in the swampy uplands of Ayer-Pununs, in Malacca, growing in company with two or three species of *Nepenthes*, and it was named by him *Grammatophyllum paludosum*. More recently it was imported from Borneo by Messrs. Veitch and Sons, of Chelsea; later it was found in Cochin China by M. Regnier, of Fontenay-sou-Bois, Paris, from whose importation the greater part of the plants now existing in European gardens have emanated.

Dipodium paludosum is an erect-growing plant with two-ranked leaves, which are ligulate, acute, thin, and membranaceous in texture, pale green, or with just a tinge of bluish, metallic green. Spike axillary, erect, bearing a raceme of six to twelve flowers, which measure individually about an inch and a half across, and are of a soft creamy white, dotted with purplish magenta. It is a plant that grows freely, but it requires a closer atmosphere than the Orchid house affords. We have grown it in a large fern case in the East Indian house, but we have seen it doing fairly well in Sir Trevor Lawrence's collection at Burford Lodge, Dorking, where many difficult plants to grow are successfully treated by Mr. White, the gardener. We have found this plant thrive best in small pots well drained, using for it a mixture of peat and sphagnum moss; it likes a very moist atmosphere all the year round, but in less proportion in the winter months.



J. Hagens Fitch del. et lith.

H.S. Williams & Son Publ^{rs}

ODONTOGLOSSUM GALLEOTTIANUM.

ODONTOGLOSSUM GALEOTTIANUM.

[PLATE 423.]

Native of Mexico.

Epiphytal. *Pseudobulbs* roundish-ovate, compressed, plump and smooth when young, becoming furrowed and wrinkled with age, green slightly suffused with ferruginous brown at the base, monophyllous. *Leaves* oblong acute, membranaceous, dark green. *Scape* rising with the young growth, three or more flowered. *Flowers* upwards of two inches across; *sepals* oblong-acute, white, the lateral ones sparingly dotted at the base with purplish magenta; *petals* ovate, much broader than the sepals, white, and like them dotted at the base with purplish magenta; *lip* large, somewhat cordate, acute, with two fleshy crests at the base, white, bearing a few streaks of yellow at the crests.

ODONTOGLOSSUM GALEOTTIANUM, *A. Richard, Orchids of Mexico*, tab. ined, p. 27, 89; *Lindley, Folia Orchidacea*, No. 22; *Reichenbach, Gardeners' Chronicle*, 1870, p. 39; *Williams, Orchid-Grower's Manual*, p. 440. *Annales des Sciences Naturelles*, 1845, Series iii., vol. 3.

The present plant is an old species first discovered about 1844, but it was not until 1870 that it was introduced in a living state to our gardens; about this time it was introduced by us with a batch of *Odontoglossum Cervantesii*, and the fact of its being so scarce induced Professor Reichenbach to presume it to be a natural hybrid; but we imagine there are plenty of small-growing kinds ensconced in quiet nooks of the mountains of Mexico and other parts of the American Continent, to which the steps of no collector have yet penetrated, so that we may reasonably hope for fresh forms and faces new when these countries become more familiar to the plant collector. No better illustration can be given of this than the finding recently of that grand species *O. Harryanum*, and still later, the beautiful little *O. Youngii*, figured in these pages at t. 406. *O. Galeottianum* has also been introduced by the Messrs. Low and Co., of the Clapton Nurseries, as well as by ourselves, so that we may live in expectation of a batch of it being found by some lucky collector at no distant date. The plant here depicted was grown and flowered in the gardens of J. Statter, Esq., of Stand Hall, Whitefield, near Manchester, where every care and attention is bestowed upon all plants, be they ever so humble or grand, by Mr. Johnson, the successful gardener in charge of this collection.

Odontoglossum Galeottianum is a dwarf evergreen species belonging to the group of which *O. Cervantesii* may be taken as the type; it has roundish ovate pseudobulbs, and it has hitherto but produced a two-flowered raceme, but as the

plant becomes stronger, we may reasonably hope to see more flowers developed. The flowers measure some two inches across, and are pure white, saving a few spots and dots of purplish magenta at the base, the lip also has a few yellow lines and streaks on the crest. We only know this plant as coming with *O. Cervantesii*, and as that plant is scattered over an immense tract of country, we cannot at present determine where to look for it, but as we can grow *O. Cervantesii* well so also *O. Galeottianum* should yield to the same treatment.

CYPRIPEDIUMS AT STREATHAM.—We called in at The Woodlands a week before Christmas, and the change from the dreary winter weather, frost and snow, which the interior of the Cypripedium house presented, was quite enchanting; such a sight makes one exclaim that there really is nothing in the Orchid world to equal these Slipper Orchids for making a display, at this season of the year especially. Here were upwards of half a hundred distinct kinds shedding their beauties around, and hundreds of bright and lively flowers, the hybrid forms which exist in such numbers in this collection being by no means destitute of charming and delicate colours. Amongst them all the old *C. insigne*, which was represented by considerably over two hundred flowers, stands supreme; a large batch of this species, which were in bloom a week or two before, had been cut for indoor decoration, or there would have been quite five hundred flowers of this alone. *C. insigne Sanderæ* is one of the very best of its forms; it was recently in bloom here, and must take the palm from all the varieties which have appeared, for the chaste delicacy of its markings. This and the exquisite *C. Fairieanum*, however, were over, and did not count amongst the many fine kinds to be seen here at Christmas. From amongst the many we select a few. One of the prettiest of Messrs. Veitch's hybrids is *C. Niobe*, between *C. Spicerianum* and *C. Fairieanum*, and which is a beautiful flower. *C. Muriel Hollington* is also a superbly chaste and beautiful form, its pure white flowers being exquisitely dotted and spotted. The superb flower recently shown and certificated under the provisional name of *C. Osbornii* seems to be an extra good form of *C. Pitcherianum*; it has been named *C. Pitcherianum superbum*, and is the result of selecting two good varieties for its parents; this plant was raised by Mr. Osborne, gardener to Mrs. Howard, The Grove, Teddington, and better known as having had charge of the Wilton House collection of Orchids, at Southampton. *C. Pollettianum* is a grand flower, something in the way of *C. ænanthum superbum*, there were also *C. ænone*, *Mrs. Charles Canham*, *Measuresianum*, *Amesianum*, *Leeanum superbum*, *Dayanum*, a grand form of *Harrisianum superbum*, and a host of others, including many bright coloured flowers belonging to the *Selenipedium* group, which up to the present time take the lead for brilliant colours.—W. H. G.



CATTELYA CRISPA DELICATISSIMA.

CATTLEYA CRISPA DELICATISSIMA.

[PLATE 424.]

Native of Southern Brazil.

Epiphytal, growing upon rocks and trees. *Pseudobulbs* erect, clavate, compressed, slightly furrowed, from eight to ten inches high, bearing a single leaf upon the apex. *Leaves* oblong-lanceolate, obtuse, emarginate, coriaceous in texture, about a foot in length, and rich deep green. *Scape* rising from the base of the leaf, and issuing from a large oblong compressed sheath, bearing a raceme of from two to three flowers, which measure individually from five to six inches across. *Sepals* lanceolate, widening upwards, entire at the margins, recurved at the tips, pure white; *petals* same colour as the sepals, but much broader, ovate, lanceolate, narrow at the base, much undulated and crisp on the margins; *lip* three-lobed, the side lobes rolled over and enclosing the column, anterior lobe oblong, acuminate, slightly recurved at the tip, much lobed and crisp on the margin, pure white, stained with lemon on the interior, throat streaked with rosy purple, the frilled edges stained with soft lilac. *Column* enclosed, clavate, triquetre.

CATTLEYA CRISPA DELICATISSIMA, *Williams, Orchid-Grower's Manual*, 6 ed., p. 177.

LÆLIA CRISPA DELICATISSIMA, *Hort.*

The present plant is a lovely variety of an old species which has been known to exist in our gardens for more than sixty years, and is familiarly known as *Cattleya crispa*, to which we have adhered instead of resorting to the name of *Lælia*. It flowered for the first time in this country in the year 1827, in the gardens of the Horticultural Society, having been sent there the year previously by Sir Henry Chamberlain. Naturally it appears to be scattered through the southern part of Brazil, and in the diamond district of Minas Geraes it is abundant, growing in immense masses. The first experiences with this species did not appear to be happy ones, the plant appearing to roll up its lip and not show its beauty, so that cultivators began to tire of it, whilst this, coupled with the high temperature in which it was grown, soon caused the majority of plant growers to set it on one side; we well remember forty years ago how it was shunned and not wanted. In the gardens of Mrs. Pearce, of Southampton, we first saw a very large quantity of these plants in splendid health, and as they had been grown cool—for that time—the plants appeared to open their lips and display their beauties in a far better manner than ever we had seen before. Either through better treatment or by the introduction of better varieties, we have arrived at the happy time when *Cattleya crispa* can be looked upon as a charming plant, the one here figured being

an especially charming and delicate variety; it is also conspicuous for the time of the year at which the flowers are produced. The present plant bloomed in our own establishment during the months of August and September of last season, rivetting the attention of all beholders by its delicate charms.

Cattleya crispa delicatissima, is a strong, robust-growing plant, with much the habit and appearance of its near ally, *Laelia purpurata*, and like it, it commences to grow in the winter months, finishing up in spring and early summer, and flowering upon the new growth soon after it is finished. Some varieties of this plant are remarkable for the extent of colour developed, of which we have already depicted one example—*Buchananiana*, figured on t. 81 of this work; it is remarkable for the well-opened lip and the richness of the purplish crimson of its large flowers. Another fine variety is *purpurea*, figured in the second volume of Warner's *Select Orchidaceous Plants*, t. 9; but the present variety, which first flowered some years ago with Sir Trevor Lawrence, Bart., M.P., is noted for the extreme delicacy of its flowers and also its well-opened lip. The sepals and petals are pure white, the sepals lanceolate, entire at the margins, with recurved tips; petals much broader, ovate-lanceolate, crisp, and much undulated on the margins; lip three-lobed, the side lobes rolled over and enclosing the column, anterior lobe oblong, slightly recurved at the tip, much lobed and crisp on the margin, pure white, tinged with lemon-yellow on the inside; throat streaked with rosy purple and stained on the crisp edge with soft lilac. It requires the same treatment which has already been given for *Laelia purpurata*, care being taken through the winter months not to wet the young growths, and upon all possible occasions it should be allowed the full benefit of the sunshine. It should be potted in peat fibre and a little chopped sphagnum moss, and this should be made firm and hard, but the roots should not be overloaded with soil.





ODONTOGLOSSUM HASTILABUM

ODONTOGLOSSUM HASTILABIUM.

[PLATE 425.]

Native of New Grenada.

Epiphytal. *Pseudobulbs* ovate, compressed, having two more or less sharp edges, much corrugated when old, light green. *Leaves* ample, in pairs produced from the apex of the pseudobulbs, oblong lanceolate, coriaceous in texture and rich green. *Scape* erect, much branched, from three to six feet in height, and having many showy flowers, which are more than three inches across. *Bracts* boat-shaped, acuminate, about equal in length to the ovary, pale green. *Sepals* and *petals* spreading, from an inch and a half to two inches long, linear-lanceolate, acute, pale greenish yellow, in some forms cream colour, transversely barred with numerous lines of dark reddish purple, the basal part being blotched with the same colour; *lip* hastate, narrow at the base, with a broadly acute front lobe, which is pure white, rich purple at the base; the crest consists of four plates, which are deep purple. *Column* quite destitute of wings, also deep purple, the anther case white.

ODONTOGLOSSUM HASTILABIUM, *Lindl., Folia Orchidaceæ*, No. 51, 1852; *Botanical Magazine*, t. 4272; *Pescatorea*, 1860, t. 11; *Bateman's Monograph of Odontoglossums*, t. 7; *Veitch's Manual of Orchidaceous Plants*, i., p. 38 (with woodcut); *Lindenia*, v., t. 213; *Williams' Orchid Grower's Manual*, 6th ed., p. 443.

The plant now under consideration has been in cultivation nearly fifty years, and we have both known and grown it for some thirty years or more, having always held it in the highest estimation. The plant is said to grow as an epiphyte on the large cable-like stems which overhang the lagoons and running streams in New Grenada, whilst it is found in other localities growing with various plants, in large masses. It occurs at a lower elevation than many of the species of *Odontoglossum*, having been found at some 2,500 feet elevation, but yet is abundant at 9,000 feet and even higher. The species is said to have been first detected by M. J. Linden, of Brussels, and the first time of its flowering in England occurred in 1846, in the collection of the Duke of Northumberland, at Syon House, Brentford, where in those days were gathered together an immense number of rare and beautiful plants. The plant whose portrait we now lay before our readers was a specimen which grew and flowered in our own collection at Upper Holloway, in the month of July in the year 1889. Its natural flowering season, however, is said to be from January to April, but it appears to be a very variable plant in its time of blooming.

Odontoglossum hastilabium is a stately species, growing to a large size, the stout pseudobulbs being flattened at the edges, much wrinkled, and bearing on the

summit a pair of leathery light green leaves, the leaves enveloping the pseudobulbs when young, being very fugacious, and soon falling away. The scape attains a height varying from two to six feet in length, the flowers being paniced; upon one panicle imported from its native country we counted more than a hundred scars, which were the impressions left by fallen blooms. The flowers are some three or four inches across, and very fragrant, spreading and showy; the sepals and petals are nearly equal, the ground colour being of a creamy green or creamy yellow, barred transversely with numerous closely arranged streaks and blotches of deep reddish purple; the front lobe of the lip is broadly acute, pure white, more or less flushed towards the base with purple, which becomes of a deeper purple at the extremity.

The plant thrives best in a pot, taking care that the drainage is kept perfectly free and open, and in good working condition. The pot should be of good size, for we have found this plant, unlike many Orchids, delights in a largish quantity of soil about its roots. The soil should consist of good peat-fibre (from which most of the fine particles have been beaten) and some chopped sphagnum moss, adding in the course of potting some nodules of charcoal, and pressing the whole down firmly. This plant thrives well with other species of *Odontoglossum* during the summer season, but during the dull dreary days of winter it should have a little more warmth than such kinds as *O. Alexandræ* appear to revel in, and therefore we recommend the Cattleya house, or a temperature which does not fall below 55° or 60°. It should be kept rather dry at the root in winter if not growing, but by no means allow it to suffer through want of water.

A WONDERFUL CALANTHE.—There was recently in flower in the collection of Orchids belonging to J. A. Rolls, Esq., Hendre, Monmouth, a plant of *Calanthe vestita oculata gigantea*, having a spike 6 feet 4 inches long, and carrying 48 fine flowers; this plant was grown in a 32-size pot in a compost of peat and loam in equal parts with a little sand and decayed manure added, and we must congratulate the gardener, Mr. Coomber, upon his method of cultivation.—H. W.



CYPRIPEDIUM PORPHYROCHLAMYS

CYPRIPEDIUM PORPHYROCHLAMYS.

[PLATE 426.]

Garden Hybrid.

Terrestrial. Acaulescent. *Leaves* distichous, ancipitous at the base, oblong-lanceolate, from four to six inches long, pale green, faintly tessellated with darker green. *Peduncle* erect, one-flowered. *Bract* boat shaped, about equal in length to the ovary, slightly hairy. *Flowers* large and showy, *dorsal sepal* roundish ovate, the central part deep rich purplish crimson, with darker veins, margin white, with a heavy border of white on the apex, and at the base a semi-lunate patch of pale green; inferior *sepal* very much smaller, greenish white, with darker veins; *petals* ligulate, much deflexed, undulate at the margins, and ciliolate, yellowish green at the base, much freckled with dark dots, the apical portion pure rich violet-purple; the pouch-like *lip* oblong-obtuse, brownish purple with darker veins on the upper side, but paler beneath, passing into green. *Staminode* purple, paler at the edges.

CYPRIPEDIUM PORPHYROCHLAMYS, *Reichenbach in Gardeners' Chronicle*, 1884, xxi., n. s., p. 476. *Veitch's Manual of Orchidaceous Plants*, iv., p. 96.

The plant here depicted is one of great beauty, and is the result of a cross between *Cypripedium barbatum Warnerianum* and *C. hirsutissimum*. It is one of the few hybrids which have hitherto flowered, that have *C. hirsutissimum* as one of the parents. It was raised by Mr. Seden, at the nurseries of Messrs. Veitch & Sons, King's Road, Chelsea, and it first flowered in 1884 when it was named by Professor Reichenbach. From the great quantity of Slipper Orchids which have been raised and are coming on now to a flowering stage, there are many inferior kinds, and many that have too close a resemblance to others already in commerce, and the same will be sure to occur from those unflowered plants which already have an existence, consequently a weeding out will be necessary, when some kinds which now stand high in favour will be cast on one side, but the plant here portrayed will occupy the first rank for a very long time, and we think will become a permanent favourite. The plant here figured was grown in the once famous collection of *Cypripediums* gathered together by F. G. Tautz, Esq., late of Studley House, Shepherd's Bush, where the plants were maintained in excellent health by his gardener, Mr. Cowley, whom we hope to again see in charge of a still finer assortment in his new home, and also that Mr. Tautz may give us some startling novelties from his many hybrid seedlings.

Cypripedium porphyrochlamys, being a seedling from two Eastern plants, from warm localities, naturally enough, likewise requires the temperature of the warmest house to grow it freely and to induce it to flower. It is an evergreen plant, having oblong leaves of a pale green, slightly tessellated with deeper green. The

peduncle is erect. At present we have only seen it bearing a single flower, but as we have seen both its parents produce two flowers, this plant may also be twin-flowered, when it becomes strong. The flowers are large and brilliantly coloured, the dorsal sepal very broad, the whole central part being rich crimson with darker veins, and the apex snowy white; the lower sepal is much smaller, greenish white, veined with green. Petals deflexed, the basal part yellowish green, freckled with blackish spots, and the edges ornamented with black hairs, the tips violet-purple; the lip is brown, shaded with purple on the upper side, paler beneath. Its flowers last a very long time in beauty.

This plant should be grown in a pot, and raised somewhat above the rim, the soil it requires being a mixture of light turfy loam, good peat fibre, some small nodules of charcoal, and a little sharp sand, the whole well mixed together. Before potting let the drainage be arranged in good working order, as the plant requires a liberal supply of water during the whole season.

AWARDS MADE BY THE ORCHID COMMITTEE OF THE ROYAL HORTICULTURAL SOCIETY FOR THE FIRST QUARTER IN THE YEAR 1891.—January 3rd, Award of Merit to Messrs. Sander and Co., St. Albans, Herts, for *Lælia anceps Ballantiniana*, a soft, delicate flower, with rosy pink sepals, and broad large petals of a deeper hue, especially towards the tips; lip intense rich maroon-crimson with a rich yellow crest. To the Right Hon. J. Chamberlain, Esq., Highbury, Birmingham, for *Lælia anceps grandiflora*, a bold and massive flower, remarkable for the breadth of its sepals and petals, which are dark rose in colour; lip very dark crimson, the throat and side lobes yellowish streaked with crimson.

February 10th, First Class Certificate to Messrs. James Veitch and Sons, The Nurseries, King's Road, Chelsea, for *Cypripedium Creon*, a hybrid between *C. ænanthum superbum* and *C. Harrisianum superbum*. It seems to be fairly intermediate between its parents, but we think, as shown, it missed the beauties of either; it was twin-flowered, and, perhaps, when it blooms again it may be seen to better advantage.

Award of Merit to Thos. Statter, Esq., Stand Hall, Whitefield, Manchester, for *Cattleya Trianae plumosa*, a very handsome form of the species, having the sepals and petals of a dark rose, median band in the latter of an intense rich rose; the lip crimson with a rich yellow throat. To Mr. Wm. Whiteley, The Nurseries, Hillingdon, for *Odontoglossum triumphans*, a form with large flowers, having the ground colour rich golden yellow, heavily marked with transverse streaks and blotches of chocolate-brown, but we have seen a much darker form.

(Continued under Plate 427).



ZYGOPETALUM MACKAYI

ZYGOPETALUM MACKAYI.

[PLATE 427.]

Native of Brazil.

Epiphytal. *Pseudobulbs* ovate, scarred with the remains of the old leaves, smooth, and deep green. *Leaves* distichous, lorate, linear-lanceolate, strongly veined, coriaceous in texture, and bright green. *Scape* erect, rising with the young growth, a foot and a half long, bearing a raceme of many flowers, which are furnished with large ovate acute bracts. *Sepals* and *petals* ascending, connate at the base, oblong-lanceolate acute, pale green, blotched and barred transversely with dark brown; *lip* undivided, spreading, obcordate, clawed at the base, pubescent, white, heavily streaked with bluish purple. *Column* semi-terete, arching. Pollen masses two, nearly sessile, on a transverse gland.

ZYGOPETALUM MACKAYI, *Hooker, Botanical Magazine*, t. 2748; *Loddiges' Botanical Cabinet*, t. 1664; *Paxton's Magazine of Botany*, iii., t. 97; *Williams' Orchid Grower's Manual*, 6th ed., p. 619.

We have in the plant now before us a well-known and much-admired species, one that has been in cultivation some sixty-five years or more, and although somewhat looked down upon and called an old-fashioned thing by the race of young beginners in Orchid-growing, it nevertheless still retains its position in the collections of those better acquainted with these plants, from the very fact that its large spreading lip displays a colour which is comparatively rare amongst Orchids, and is highly prized by all. Moreover as the flowers are produced through the late autumn and winter months, yield an exquisite perfume, and last a very long time in full perfection, it is no wonder this fine old plant is very popular. As a proof of this, a friend recently sent us a fine photograph of this species, it being a plant having eight spikes, which together bore fifty flowers, and these being all open at one time, he said the delicious scent of these blooms was highly appreciated by the ladies of his family, who had the plant standing in the dwelling house for about seven weeks, and after this time the blooms were in excellent preservation. The plant which we here figure was grown in the Victoria and Paradise Nurseries, Upper Holloway, where it bloomed in the month of October, 1889, and flowers from the same plant were cut for personal decoration the following Christmas; but during this time we carefully guard the blooms from the syringe, and also from drip which may condense on the roof. Indeed, we contend that every Orchid grower should adopt the preventative which does away with all such danger to not only flowering plants, but the tender leaves as well.

Zygopetalum Mackayi is a large-growing evergreen plant, which may easily be grown to a fine specimen, and if good strong growth is made, it will flower freely, although we were informed recently by a gentleman that he had a large plant which grew well, but had not flowered for the last five years, which we look on as a most unusual occurrence. There are, however, numerous varieties of this species, and it might be the case that a shy bloomer has fallen to his lot. The plant has large ovate pseudobulbs, and long green distichous leaves. The scape rises with the young growth, and attains to a foot or eighteen inches in length, bearing some six or eight flowers, which are large and delicately fragrant. They last a long time in full beauty, but the spikes should be cut before the plant suffers in health, in order that good well-ripened bulbs may be made for the next season's blooming. We are of opinion that this is a plant which, to flower freely, requires to be slightly pot-bound, and, therefore, although willing to admit that a good-sized pot is necessary for its sustenance, and to accommodate its large roots, frequent re-potting should not be resorted to. Therefore see that the drainage material is properly adjusted, and every season the old soil should be taken out, and it must be replaced with new. The soil in which to grow this plant should be a mixture of good peat fibre and sphagnum moss, to which may be added a little light turfy loam, from which all the fine particles have been shaken; this must be packed in very tightly. During the growing season a good heat is necessary, the Cattleya house being about the right temperature; it also requires a moist atmosphere, and a liberal supply of water to its roots.

AWARDS MADE BY THE ORCHID COMMITTEE OF THE ROYAL HORTICULTURAL SOCIETY
(Continued from Plate 426).

March 10th, First Class Certificate to Messrs. F. Sander and Co., St. Albans, Herts, for *Odontoglossum luteo-purpureum* var. *Amesianum*, a form of this variable plant having a pale yellow or yellowish green ground colour, with blotches of dark chocolate on the sepals and petals, the lip being pale yellow heavily fringed.

Award of Merit to G. Hardy, Esq., Pickering Lodge, Timperley, Cheshire, for *Cattleya Trianae Hardyana*, a charming variety with very broad sepals and petals, making a round full flower, the lip having a rich deep purple front lobe with a narrow, pale, marginal band.



CYPRIPEDIUM LOWII

CYPRIPEDIUM LOWII.

[PLATE 428.]

Native of Sarawak, West Borneo.

Epiphytal. Acaulescent, with distichous oblong-ligulate leaves, which are equitant at the base, and somewhat two-lobed at the apex, coriaceous in texture, from a foot to fifteen inches in length, upwards of an inch in breadth, and bright light green in colour. *Scape* two to three feet in length, bearing usually two flowers, although at times more are produced. *Bracts* ovate-acute, much smaller than the ovary, strongly ribbed, and light green. *Flowers* nearly six inches across the petals, showy, and all the segments fringed with black hairs; *dorsal sepal* ovate, acute, somewhat hooded at the apex, keeled at the back, and contracted at the base, where it is stained with brownish purple, the upper part being pale green when it first expands, which, however, passes with age into soft yellow; *inferior sepal* similar in colour, but smaller; *petals* spathulate, slightly deflexed, upwards of three inches long, the basal part greenish yellow marked with large spots of blackish purple, apical part clear bright violet-purple; the pouch-like *lip* oblong-obtuse, purplish green on the upper side, greenish beneath. *Staminode* inversely cordate, having an erect tooth at the base, and another small one on the edge of the inner part, or sinus.

CYPRIPEDIUM LOWII, *Lindley, Gardeners' Chronicle*, 1847, p. 765; *Flore des Serres*, iv., t. 375; *Veitch's Manual of Orchidaceous Plants*, iv., p. 38; *Les Cypripedieés*, i.; *Florist and Pomologist*, 1870, p. 109, with fig.; *Gardeners' Magazine of Botany*, i., t. 297; *Annales des Gand*, 1848, t. 195; *Williams' Orchid Grower's Manual*, 6th ed., p. 250.

CYPRIPEDIUM CRUCIFORME, *Zolling*.

The present species has been known to Orchid collectors in this country for about forty-five years. It is a native of Sarawak, on the West Coast of Borneo, a settlement founded by Sir James Brooke, and the province still remains under British rule, although not under the dominion of the Crown. The plant was discovered by Mr. Hugh Low (now Sir Hugh) growing high up on the branches and in the forks of the tall trees which abound in that island. The plant was sent to the nurseries of Messrs. Low and Co., of Clapton, and it remained a rare plant in our gardens for some years, but is now more plentiful. The only other species which resembles this one is *Cypripedium Haynaldianum*; a plant found in the Philippines some eighteen years ago, which nevertheless is very distinct from it, and at the same time a most beautiful species.

Cypripedium Lowii is dedicated to its discoverer, Sir Hugh Low, but through some mistake the name appeared as *Loweii*. It flowered for the first time in this country in the collection of Mr. A. Kenrick, and the plant here figured flowered

in our collection at Holloway, in the month of January, 1889, although its usual time of flowering in a natural state would appear to be April and May. The plant is a robust and strong grower, and has distichous leaves, which are oblong-ligulate, a foot or more in length, and light green in colour. The scape is erect, from two to three feet in length, and under cultivation it usually produces two flowers only; but on native specimens we are told that sometimes eight or ten are developed. The dorsal sepal is ovate-acute, somewhat hooded at the apex, and narrowed at the base, pale green tinged with brownish purple, downy on the outside; the lower sepal slightly smaller, but about the same colour. Petals deflexed, three inches or more in length, the apical portion soft violet-purple, the basal half greenish, spotted with purple; the edges fringed with black hairs. The lip is oblong and stout, smooth and shining, greenish purple on the upper side, passing into pale green beneath. It blooms during the late winter and early spring months, and continues in full beauty for a very long time, but its flowers must be kept from damp.

Cypripedium Lowii, although growing naturally as an epiphyte upon the branches of trees, we yet find to succeed best under cultivation when grown in a pot; this should be well drained. We have found it thrive best in a mixture composed of one part good light turfy loam, the same of peat and leaf-mould, to which may be added a little chopped sphagnum moss, and a few moderate-sized nodules of charcoal, the whole to be well mixed and incorporated. In potting, the plant should be a little elevated, so that the water may the more readily pass away quickly from the crown and young growths. This plant, like all the rest of the genus, has no pseudobulbs, and therefore requires attention in watering all the year round. In the summer months a liberal supply is requisite, and during the winter sufficient will be necessary to maintain the specimen in perfect health. The warmth of the East India house suits this species best, it will thrive, however, in the Brazilian house during summer, but in winter more heat is necessary than is accorded to *Cattleyas*, where these plants are properly rested.

GIANT FORM OF *LYCASTE SKINNERII ALBA*.—We have received through the kindness of T. Statter, Esq., Stand Hall, Whitefield, near Manchester, flowers of a grand variety of this great beauty, the individual flowers measuring eight inches across, and being of good substance; the sepals too were unusually large. This is another instance of Mr. Statter's good luck in flowering gems in his collection.—H. W.



ODONTOGLOSSUM MULUS HOLFORDIANUM

ODONTOGLOSSUM MULUS HOLFORDIANUM.

[PLATE 429.]

Native of the United States of Colombia.

Epiphytal. *Pseudobulbs* clustered, ovate, stout and compressed, attaining some three or four inches in height, dark green, smooth when young, becoming more or less furrowed with age, and bearing on the apex a pair of ensiform acute deep green leaves, the accessory basal leaves, although these die quite away, are less fugacious than in many of the species and varieties of this genus. *Scape* erect, issuing from the side of the pseudobulb at its base, arching, reaching sometimes to three feet in length, terminating in a dense raceme of large and very showy flowers; these are spreading, some four inches across. *Sepals* and *petals* nearly equal, oblong-lanceolate, acuminate, waved and undulated, but not toothed; ground colour light yellow, profusely blotched with large irregular-shaped spots of brown, tinged with purple; *lip* somewhat panduriform, coarsely dentate on the margin, cuspidate, bearing a toothed crest, light yellow, bearing two large spots of purplish brown in front of the crest, and numerous smaller ones scattered over the surface. *Column* bent, with a pair of smaller toothed wings.

ODONTOGLOSSUM MULUS HOLFORDIANUM, *Reichb. fil, Gardeners' Chronicle*, 1882, N.S., xviii., p. 616. *L'Orchidophile*, 1885, p. 132. *Williams' Orchid-Grower's Manual*, 6 ed., p. 452.

This plant is probably one of the various mule forms of *Odontoglossum luteo-purpureum* of Lindley, a species which was originally discovered by M. Linden, of Brussels, when travelling in New Grenada, nearly half-a-century ago; since that time the plant has been found to be widely distributed in that country, necessarily varying considerably in form and brilliancy of markings. Notwithstanding the fact that collectors had been in these cool regions and seen the plants thriving under conditions so very different to those they were subjected to at home, nothing appears to have been said by them relative to this matter; this was the greatest drawback to the establishing of South American Orchids in our collections, and it was not until after the year 1850 that the observations of Warscewicz upon this very subject bore fruit, in an experiment which was carried out in the establishment of the late Messrs. Thomas Jackson and Son, at Kingston, in Surrey: who started a cool Orchid house, and many were the doubts and fears expressed for the plants therein through the first winter; but they came through well, and the example set soon became common in the land. It was the first cool house that ever existed in this country, and in it were saved and flowered many of the last discoveries of Warscewicz. The plant whose portrait we here have the pleasure to lay before our readers was grown in the fine collection of R. S. Holford, Esq., Weston Birt, Tetbury, under the care of Mr. Chapman, the able gardener.

Odontoglossum mulus Holfordianum is a compact-growing evergreen plant; its long arching spike of bloom and large showy flowers make it very attractive in a collection. Messrs. Low and Co., of Clapton, may be congratulated upon being the first to introduce *O. mulus* to cultivation, and this, a superior form of the same plant, is ever welcome. In its native home it occupies a wide range, and is found at between 7,000 and 9,000 feet elevation, so that it is a thoroughly cool plant. It requires to be potted in well-drained receptacles, using for soil, peat that has been well beaten to remove the earthy parts, and to this may be added some chopped sphagnum moss, the whole to be made very firm and hard. The plant should be elevated a little above the rim of the pot, and during the growing season an abundant supply of water will be necessary, but in the dull winter months less should be given; yet at no time in the year should the plant be dried.

Care and attention must be given these plants during the hot summer months, as we have found this species and its near allies to be extremely subject to the attacks of thrips and red-spider—the first, doubtless, encouraged by want of ventilation, and the second through the atmosphere being kept too dry.

THE ROYAL HORTICULTURAL SOCIETY'S EXHIBITION IN THE TEMPLE GARDENS, *May 29th and 30th*, 1891.—This show, opened by the Princess Christian, was a remarkable success, and in the display of Orchids far exceeded anything that has hitherto been seen in public. Taking the amateurs' groups as they stand, we come to that of Sir Trevor Lawrence, Bart., M.P., Burford Lodge, Dorking. This group was very fine, and Mr. White may well be proud of the condition in which the plants were staged. Some of the finest plants in the group were the pure white *Cattleya Wageri*, stained only in the lip with yellow; *C. Schroderæ*, well flowered and deliciously scented; *Cypripedium grande atratum*, which, as its name implies, is a very dark variety of this hybrid; *C. Wallisii*, and a fine spike of *C. Rothschildianum*. In Masdevallias we have a richness of colour produced by no other plants in the order, and here were very fine examples of *M. Harryana miniata*, with brilliant red flowers; *M. Harryana Bull's Blood*, rich deep crimson; *M. Harryana sanguinea*, deep blood colour, and many others. A fine nearly white form of *Miltonia (Odontoglossum) vexillaria*, called Fairy Queen, and *Maxillaria Sanderiana* were noticeable. Baron Schröder, The Dell, Egham, also showed finely, his group comprising *Odontoglossum Pescatorei Veitchianum*, a wonderful plant, perfectly unique; *Aërides Williamsii* (spike only), a pure white form of *A. Fieldingii*; *Masdevallia Veitchiana*, with twenty-seven flowers of large size and intensely rich colour; *Cattleya Skinneri*, very fine, with thirty-nine spikes; a white variety of *C. Mendelii*, which, however, did not appear to us quite as pure as Blunt's variety; *Odontoglossum excellens*, a charming form; *O. Wilckeunum*, *O. crispum Bonnyanum*, *Cælogyne pandurata*, and many other gems, of which Mr. Ballantine may well be proud. Mr. Salter, gardener to T. B. Haywood, Esq., Woodhatch Lodge, Reigate, staged a very pleasing group, composed of Cypripediums, Masdevallias,

(Continued under Plate 430.)



J. A. S. Pich del. et lith.

CYMBIDIUM ELEGANS.

B. S. Williams & Son pub'rs

CYMBIDIUM ELEGANS.

[PLATE 430.]

Native of Northern India.

Terrestrial. *Pseudobulbs* clustered, stout, ovate, marked with the scars of fallen leaves, and producing thick fleshy roots. *Leaves* numerous, distichous, arching, sheathing at the base, linear-lorate, acute, keeled beneath, some two or more feet long, rich bright green in colour. *Scape* lateral, pendent, furnished with long boat-shaped bracts, and terminating in a long dense raceme of tawny-yellow flowers, which are half closed, *i.e.*, having the sepals and petals connivent. *Sepals* and *petals* oblong, about equal; *lip* three-lobed, side lobes small, rolled close to the column, the middle lobe much dotted with deep red, the other portion of the flower tawny-yellow.

CYMBIDIUM ELEGANS, *Lindley, Sertum Orchidaceum*, t. 14. *Williams' Orchid-Grower's Manual*, 6th ed., p. 233.

The plant whose portrait we now have the pleasure to lay before our readers has hitherto been kept in our collections more on sufferance than for the beauties of its inflorescence, and we were highly pleased to receive the fine spike here depicted, as well as to see the magnificent specimen of it which was flowering last season in the Woodlands collection of R. H. Measures, Esq., at Streatham, in Surrey. It convinced us at once that the species has really been mismanaged for years, and has thus been prevented from displaying its real merits, which are of such a character as would recommend it to the care of all lovers of Cymbidiums. This species is said to have been introduced from Nepaul fifty years ago, but it never was imported in quantity, and if this plant were kept in the same temperature to which *C. eburneum* and many other things were treated at that time, there is little wonder that the plant did not thrive and increase, or that its beauties have been so long in receiving recognition. The specimen here depicted was grown in the collection of W. J. Thomson, Esq., St. Helens, Lancashire.

Cymbidium elegans, as its name implies, is a neat and handsome plant, producing linear-acute leaves, which are arching, bright green, and persistent. The flowers are produced in massive pendulous spikes, and are tawny-yellow in colour, a shade with which we are not much acquainted in this genus. We are told, however, that there are many fine yellow-flowered species in the South African district which have never yet been introduced to this country in a living state, and we trust that amongst the number of persons now directing their steps to that country, some may be interested enough in botanical and horticultural pursuits to send home to their friends and relations some of these choice and rare kinds.

Cymbidiums thrive well in the temperature of the Cattleya house, and even a little less warmth will suit them well, especially during the winter. In the summer months they enjoy an abundance of water, both to their roots and overhead in sprinklings from the syringe, but they should not be exposed to the mid-day sun when the foliage is wet, as this will cause the leaves to become spotted; in this condition they do not present a nice appearance. In the winter much less moisture is necessary, but the plants must not be allowed to become dry at any season. They are very large-rooted plants, and therefore require larger pots than the majority of Orchids, but this need not be carried to excess. The soil we find to suit these plants best is about two parts good turfy loam, one part fibrous peat, and one part good leaf-mould, adding a little sharp sand and some medium-sized nodules of charcoal to help in keeping the soil in a porous condition.

THE ROYAL HORTICULTURAL SOCIETY'S EXHIBITION IN THE TEMPLE GARDENS.

(Concluded from under Plate 429.)

Odontoglossums, etc. Mr. Cummins, gardener to A. H. Smee, Esq., The Grange, Carshalton, had an excellent group of well-grown plants, composed chiefly of fine varieties of *Cattleya Mossiæ* (for which this place is becoming famous), Odontoglossums, Masdevallias, Cypripediums, etc. Malcolm S. Cooke, Esq., of Kingston Hill, showed a pretty group. Mr. Young, gardener to F. Wigan, Esq., Clare Lawn, East Sheen, staged a nicely arranged group, composed of well-flowered Vandas, Oncidiums, Cypripediums, Cattleyas, *Cymbidium tigrinum*, *Pescatorea cerina*, *Sarcochilus Berkeleyi*, and many other things. Mr. Whillans, gardener to the Duke of Marlborough, set up a large and excellent group, amongst which were very conspicuous *Cymbidium Lowianum*, *Cattleya Lawrenceana*, a grand *Lælia purpurata*, fine forms of *Cattleya Mendelii*, *Uropedium Lindeni*, *Epidendrum prismatocarpum*, *Odontoglossum Phalænopsis*, etc. Mr. Reynolds, gardener to Messrs. de Rothschild, Gunnersbury Park, Acton, showed a very fine group of well-flowered *Vanda teres*. Mr. J. Godfrey, gardener to Major-General E. S. Berkeley, Bitterne, Southampton, staged a group of Phalænopsis, composed mostly of *P. speciosa*, *P. Imperator*, and *P. tetraspis*, the pure white flowers being very effective. R. B. White, Esq., of Arddarroch, N.B., staged a beautiful *Odontoglossum crispum*, with heavily spotted flowers, and some very pretty *Cattleya Mendelii*, etc. Mr. Elliot, gardener to F. Darnell, Esq., Stamford Hill, sent a very nice group of Cattleyas and Lælias, beautifully grown and flowered plants. Mr. Mitchell, gardener to Mrs. Arbuthnot, Bridgend Place, Bexley, sent a superb group, having a grand specimen of *Sobralia macrantha* in the centre; *Lælia purpurata*, *Cypripedium caudatum*, *Brassavola Digbyana*, and many other fine plants. Mr. Burnett, of Stoke Newington, sent some well-grown and beautifully flowered specimens of *Lælia purpurata*. T. Statter, Esq., of Stand Hall, Whitefield, Manchester, although confined to his bed for some time, sent a large and beautiful collection of cut Orchid flowers. This comprised about all the amateur exhibitors. The trade collections we will speak of in our next number.



Wm. T. A. S. P.

MASDEVALLIA MACRURA .

B. S. Williams & Son. 1877

MASDEVALLIA MACRURA.

[PLATE 431.]

Native of the Province of Tolima, U.S. Colombia.

Terrestrial. A strong-growing and robust-habited plant, quite destitute of pseudo-bulbs, having in their place slender stems, which in the young state are enclosed in large sheaths; the *stems* attain a height of some five or six inches, each bearing a single, large, oblong-obtuse leaf, emarginate at the apex, thick and leathery in texture, from nine inches to a foot in length, and from two to three inches in breadth. *Scape* erect, from nine inches to a foot long, single-flowered. Flowers large, in fact being the largest species known in the CUCULLATA section, to which *M. macrura* belongs. The sepaline tube is short and ribbed, dull brownish yellow externally, the interior of the tube and sepals being bright reddish brown or tawny yellow, marked with numerous very deep purplish warty spots and dots; *sepals* prolonged into stout tails some six inches in length, yellow; *petals* small, oblong, yellowish brown; *lip* also oblong, reflexed at the tip, tawny yellow dotted with purple.

MASDEVALLIA MACRURA, *Reichenbach fil.*, in *Gardeners' Chronicle*, 1874, N.S., i., p. 240. *Id.* vii., p. 12. *Lindenia*, iii., t. 113. *Veitch's Manual of Orchidaceous Plants*, Part v., p. 51. *Linnæa*, xli., p. 11. *Williams' Orchid-Grower's Manual*, 6th ed., p. 395.

The credit of first discovering this giant amongst the Masdevallias is due to the veteran traveller and explorer in South America, M. Roezl, who is said to have found it growing upon the ground in rocky places only slightly covered with moss; none of Roezl's plants, however, came to this country alive. After this M. Patin, then collecting for us in New Grenada, sent it home on several occasions, but the plants always arrived in a dead or dying condition. To Mr. Shuttleworth, when collecting for Mr. Wm. Bull, of Chelsea, in 1876, we are indebted for the successful introduction of the plant in a living state to English gardens, and it flowered in Mr. Bull's establishment in the course of the following year. The plant here depicted was drawn by our artist in the garden of A. H. Smee, Esq., The Grange, Carshalton, Surrey, a spot made famous by the elder Smee by the publication of his work "My Garden." The place is still ably maintained by his son, who, with the assistance of his gardener, Mr. Cummings, is now adding a large collection of Orchids to the many valuable and interesting plants to be found therein.

Masdevallia macrura is a bold-growing and gigantic plant for one of its race, and its name is derived from its length of tails; it is the largest growing and flowering species which we know in the family, saving some of those plants included in the CHIMÆRA

group, or section *SACCOLABIATÆ* of Reichenbach, and some of these species measure more across the flower, from the tip of the dorsal sepal to the tip of the lateral ones, than does the plant now under consideration. This species is an evergreen plant, usually attaining to a foot or eighteen inches in height, bearing large leathery leaves of a deep green hue, the flowers being also very large and singularly beautiful; the sepals, which in *Masdevallias* serve to make the display, together with the short tube, being bright reddish brown or tawny yellow on the inner side, ribbed, spotted and dotted with numerous blackish purple, wart-like excrescences, but on the exterior the colour is duller, the long, sepaline tails being yellow. It grows naturally at some 6,000 or 7,000 feet elevation, and at this altitude, where *Masdevallias* exist in great quantities, the atmosphere is much rarified and the temperature very cool. The usual state under which the *Masdevallias* of New Grenada grow we are told is frequent and heavy rains for nearly the whole year, and dense fogs, with the temperature in the morning about at freezing point. To imitate such conditions under artificial treatment is almost a matter of impossibility, but we have found that these plants thrive best under the very coolest treatment; in the very hottest part of the year the thermometer should not exceed 70°, and even a few degrees lower would be better. To effect this, proper care should be given to shading from the sun, by keeping the atmosphere well charged with moisture, and by giving a proper amount of air. This treatment in a lean-to house with a northern aspect will result in giving plants with clean, healthy leaves, and in due season an abundance of flowers. *Masdevallias* will succeed well with many species of *Odontoglossums*, such as *O. triumphans*, *O. Hallii*, *O. crispum*, &c., but when a large collection is aimed at, we would always recommend a separate structure for their maintenance. This plant, being a large and vigorous grower, thrives best in a pot, which should be nearly filled with drainage, and for soil use a little peat fibre and chopped sphagnum moss, pressing it down firmly, but not using a great quantity of mould about its roots.

Masdevallias grown under the above conditions will not require so much attention to keep them free from thrips as when subjected to more heat, but care must be continually given to prevent the accumulation of insects upon them; the worst that can be allowed to gain a footing are the red and black thrips, as they leave large black marks upon the under side of the leaves which cannot be eradicated.



CATILEYA DOWIANA AUREA. (Young's var.)

CATTLEYA DOWIANA AUREA (YOUNG'S VAR.).

[PLATE 432].

Native of Antioquia, United States of Colombia.

Epiphytal. *Pseudobulbs* stout, clavate, becoming furrowed with age, monophyllous. *Leaves* oblong-obtuse, coriaceous, evergreen and persistent. *Scape* erect, terminal and stout, bearing three to four flowers, each flower measuring some six inches or more across; *sepals* linear-lanceolate, plain at the edges; *petals* much broader than the sepals, ovate, undulated and dentate, all of a rich bright yellow; *lip* obcordate, three-lobed, side lobes not meeting over the column, deep maroon-purple, streaked with forked lines of rich golden yellow, anterior lobe deeply cleft in front, beautifully undulated at the margin, having next the throat two rich golden yellow large eye-like spots; the centre of the lobe and the border all round is deep rich maroon-purple, more or less streaked with broad lines of bright golden yellow.

CATTLEYA DOWIANA AUREA (Young's var.), *supra*.

CATTLEYA DOWIANA AUREA, *Williams and Moore, Williams' Orchid Album*, ii., t. 84; *L'Illustration Horticole*, 3rd series, t. 493; *Reichenbachia*, i., t. 5; *Lindenia*, i., t. 28; *The Garden*, xxi., t. 322, p. 80; *Williams' Orchid-Grower's Manual*, p. 180.

Cattleya Dowiana aurea was first sent home by Gustav Wallis from New Grenada about twenty-three years ago, and Roezl, who afterwards found it, fixes the locality in which it grows some 600 miles distant from that of the typical *C. Dowiana*, which had been introduced to our gardens a few years previously from Costa Rica, by Mr. Skinner; but it was originally found about 1850 by the veteran Polish traveller and collector, Warscewicz, whose consignment of plants, however, arrived in this country dead. It had been the intention of Warscewicz to dedicate this fine *Cattleya* to the famous Mrs. Lawrence, of Ealing, the most enthusiastic patroness of horticulture in her day; but in the *C. Lawrenceana* since discovered in British Guiana, we have a very beautiful and distinct plant (see ORCHID ALBUM, vol. viii., t. 242). This is dedicated to her equally interested son, Sir Trevor Lawrence, Bart., M.P., Burford Lodge, Dorking, Surrey, the president of the Royal Horticultural Society of England.

Cattleya Dowiana aurea, although separated by so long a distance from the typical plant, with no intermediate station between, as far as is known, cannot lay claim to be anything but a geographical variety of it; but yet it is a superior form, and the one here figured must be allowed to claim first rank in the way of varieties. Its principal differences are in the rich clear golden yellow of its sepals and petals, and the amount of the same rich colour upon its lip. This variety originated with Reginald Young, Esq., Fringilla, Linnet Lane, Liverpool, who, when it flowered

again last season, kindly sent it to us for depicting in the ALBUM. We recently saw the plant, which was looking in the best possible order, and we have much pleasure in recording the fact that Mr. Young's plants are in the very best of health and condition.

This plant belongs to the LABIATA section of the Cattleya family; it is an evergreen, of strong growth, with clavate stems, and large, oblong, deep green leaves. The flowers appear soon after growth is completed in the autumn, and remain some few weeks in full perfection if they are kept from sprinklings from the syringe, or from damp of any kind. It grows naturally near Frontino, in the company of *Cattleya gigas*, and several apparent hybrid forms have appeared from amongst the plants imported from that neighbourhood; the best of these are *C. Hardyana* and *C. Massaiana*, see ORCHID ALBUM, vol. v., t. 231 and vol. viii., t. 362. Several plants having similar markings have from time to time appeared, but none can equal *C. Hardyana* in the richness of colour or in the undulations of its crisp lip. *C. Dowiana aurea* requires to be kept dry and cool immediately after its growth is completed, and it should not be allowed to stand in strong heat until growth starts again, as we recently observed had been the case with one grower of these plants, who had half made growths in the middle of winter. Such growths never can flower, and by such treatment it gets the character of being a shy bloomer, but which it does not deserve if the plant is carefully handled in the autumn and the winter growth is avoided. It enjoys an abundance of sun and light, and to obtain this we grow it in a basket, so that it may be hung up near the roof-glass, the basket being thoroughly well drained. The soil should be good fibrous peat and a little chopped sphagnum moss, mixing a few medium-sized nodules of charcoal with the soil during potting for the purpose of keeping it open; during the growing season it is a plant which likes a liberal supply of water, hence the necessity of providing ample drainage, for although Cattleyas like water, they cannot long survive or keep in a healthy condition if it remains in a stagnant state about their roots.

Propagation may be effected by division and by cutting through the woody rhizome, but this we advise growers to be cautious about doing, because more value is attached to a fine plant all of one piece than of several small plants which have been obtained by propagation; and these small plants so obtained oftentimes do not flower for years, as they cannot obtain the nourishment they had when on the old plant.

VOL. IX.—PART 97.

MISSOURI
BOTANICAL
GARDEN

PRICE, 5s.

THE
ORCHID ALBUM,

COMPRISING

COLOURED FIGURES AND DESCRIPTIONS

OF

NEW, RARE, AND BEAUTIFUL

ORCHIDACEOUS PLANTS.

CONDUCTED BY

ROBERT WARNER, F.L.S., F.R.H.S.,

AUTHOR OF SELECT ORCHIDACEOUS PLANTS,

AND

BENJAMIN SAMUEL WILLIAMS, F.L.S., F.R.H.S.,

AUTHOR OF THE ORCHID GROWERS' MANUAL, ETC.

THE COLOURED FIGURES BY JOHN NUGENT FITCH, F.L.S.

CONTENTS.

- PLATE 385. CATTLEYA MASTERSONIÆ.
„ 386. BIFRENARIA AURANTIACA.
, 387. ODONTOGLOSSUM ALEXANDRÆ WILSONII.
„ 388. CATTLEYA EL DORADO VIRGINALIS.

LONDON:

PUBLISHED BY B. S. WILLIAMS,

AT THE

VICTORIA AND PARADISE NURSERIES, UPPER HOLLOWAY, N.

[All Rights Reserved.]

CASES FOR BINDING the Volumes of this Work can be supplied, PRICE 3s. 6d. EACH.
ALL BACK PARTS KEPT IN STOCK.

B. S. WILLIAMS'

SELECTION OF PLANTS

SUITABLE FOR

**AUTUMN and WINTER FLOWERING and
EARLY FORCING.**

NOW READY FOR DELIVERY.

	PER DOZ.
Acacia armata	12s. and 18s.
Andromeda floribunda	18s. ,, 30s.
Azalea indica (of sorts)	24s., 30s. ,, 42s.
" mollis (seedling)	15s., 18s., 30s. ,, 42s.
Begonias (winter-flowering)	18s. ,, 24s.
Bouvardias, including the new double scarlet,	18s. ,, 24s.
Camellias (of sorts)	30s. ,, 42s.
Carnations, Tree (of sorts)	18s. ,, 30s.
Citrus sinensis (with fruits)	42s. ,, 60s.
Cyclamen (of sorts)	24s. ,, 30s.
Daphne indica rubra	30s. ,, 42s.
Deutzia gracilis	18s. ,, 24s.
" crenata fl. pl. (in pots)	18s. ,, 30s.
" Pride of Rochester (from the ground)	18s. ,, 24s.
Epacris (of sorts)	24s. ,, 30s.
Epiphyllums (of sorts)	30s. ,, 42s.
Ericas (of sorts)	18s., 24s. ,, 30s.
Gardenias (of sorts)	24s. ,, 30s.
Hydrangea paniculata grandiflora... ..	12s. ,, 24s.
Jasminum grandiflorum	30s. ,, 42s.
Kalmia latifolia	30s. ,, 42s.
Laurustinus, nice compact heads... ..	18s. ,, 24s.
Lilac alba virginalis	42s.
" Charles X... ..	30s. ,, 42s.
" persica	30s. ,, 42s.
Primula sinensis alba plena	18s. ,, 24s.
" " Double (of sorts)	30s. ,, 42s.
Prunus sinensis alba plena	18s. ,, 30s.
Rhododendrons, Hardy, choice selection	24s. ,, 42s.
Roses, finest Teas and Hybrid Per- tuals, strong plants	30s. ,, 42s.
Solanum hybridum Empress, and others,	24s. ,, 30s.
Staphylea colchica	24s. ,, 30s.
Viburnum Opulus (Guelder Rose)	24s. ,, 30s.

B. S. WILLIAMS'

CHOICE SELECTION OF BULBS & ROOTS.

	PER DOZ.
Achimenes, choice selection	12s., 18s. and 30s.
Amaryllis, " " named kinds... ..	42s. ,, 105s.
" " " seedlings	30s. ,, 42s.
Begonias (Tuberous-rooted), choice named	30s. ,, 42s.
" " unnamed, 12s., 18s. ,, 24s.	
Dahlias (Single and Double), pot roots, 6s., 9s. ,, 12s.	
Dielytra spectabilis, extra strong clumps	5s. ,, 9s.
Eucharis amazonica	24s. ,, 30s.
Gloriosa superba ... each, 5s. 0d.	
" Plantii	2s. 6d.
Gloxinias, choice named selection	18s., 24s. ,, 30s.
" Seedlings, good bulbs	12s. ,, 18s.
Helleborus niger (Christmas Rose)	15s., 18s. ,, 30s.
Hyacinthus candicans, per 100, 12s. 6d. and 20s. 2s. 6d. ,, 4s. 6d.	
Lily of the Valley, imported clumps	12s. ,, 15s.
" " " single crowns, per 100, 6s.	
Spiræa japonica, strong clumps	5s. ,, 9s.
" astilboides " each, 3s. 6d.	
" aurea variegata, strong clumps, each, 1s. 9s.	
" palmata, strong clumps... ..	9s. ,, 12s.
Vallota purpurea (Scarborough Lily)	18s. ,, 30s.

GLADIOLUS.

	PER DOZ.
Brenchleyensis, per 100, 5s. and 7s. 6d.	1s. 3d.
Colvilli, The Bride (the best for cutting)	1s. 6d.
English-grown Seedlings, per 100, 17s. 6d. and 21s. 2s. 6d.	

LILIUMS.

	PER DOZ.
Auratum	12s., 18s., 30s. and 42s.
Candidum (home grown) ... per 100, 25s.	3s.
" (imported), per 100, 15s. and 20s.	3s.
Chalcedonicum	9s. ,, 12s.
Croceum	per 100, 21s. 3s.
Excelsum	15s.
Harrisii	10s., 15s., 18s., 24s., 30s. ,, 42s.
Lancifolium album	12s.
" roseum	7s. 6d.
" rubrum	7s. 6d.
Longiflorum	4s. 6d.
Martagon purpureum, purple... ..	5s. 6d.
" rubrum, scarlet	12s.
Tigrinum	per 100, 12s. 2s.

TUBEROSES.

	PER DOZ.
American, imported, ready in December, per 100, 25s.	4s.
Pearl, extra fine	4s. and 5s.
" Excelsior, very fine	5s. ,, 6s.

VICTORIA AND PARADISE NURSERIES,
UPPER HOLLOWAY, LONDON, N.

B. S. WILLIAMS'

Select List of Bulbs for Very Early Forcing.

HYACINTHS.

EARLY WHITE ROMAN (best quality)	per 100, 17s. 6d.	Per doz.—s. d.
NAMED HYACINTHS, specially selected for early forcing 2 6
		9s. & 12 0

The following are the best for very early forcing—

Albertine pure white	Norma deep blush
Alba maxima "	Tubiflora "
Blanchard "	Homerus deep rose
Crown Princess "	Rubra maxima "
La Tour d'Auvergne "	Grand Lilas... .. light blue
Elfrida blush	General Lauriston deep blue

EARLY SINGLE TULIPS.

	Per 100.	Per doz.		Per 100.	Per doz.
	s. d.	s. d.		s. d.	s. d.
Canary Bird, fine yellow	14 0	2 3	Duc Van Thol, yellow... ..	12 6	1 9
Duc Van Thol, red and yellow	5 6	1 0	L'Immaculee, white	12 0	1 9
" " " gold striped	6 0	1 0	Le Matelas, rose	27 6	3 9
" " " rose	12 6	1 9	Pottebakker, white	14 0	2 3
" " " scarlet	6 0	0 9	Proserpine, deep rose	17 6	2 6
" " " white	17 6	2 6	Vermilion Brilliant, vermilion... ..	14 0	2 3

EARLY DOUBLE TULIPS.

	Per 100.	Per doz.		Per 100.	Per doz.
	s. d.	s. d.		s. d.	s. d.
Duc Van Thol, red and yellow	3 6	0 8	Murillo, rosy white	12 6	1 9
Imperator rubrorum, crimson-scarlet	15 0	2 3	Tournesol, red and yellow	10 0	1 6
			" yellow	15 0	2 3

NARCISSUS.

	Per 100.	Per doz.		Per 100.	Per doz.
	s. d.	s. d.		s. d.	s. d.
Double Roman	8 0	1 6	Poeticus flore pleno	6 6	1 0
Paper White	8 0	1 6	" ornatus	10 6	1 9
EARLY PAPER WHITE, large-flowering. Flowers stronger and earlier than the old variety				10 6	1 3

LILIUM HARRISII

(The Bermuda Easter Lily).

STRONG BULBS	10s., 15s., 18s., 24s. & 30s. per doz.
EXTRA STRONG BULBS	3s. 6d. each.
FREESIA REFRACTA ALBA	per 100, 10s.; per doz., 1s. 9d.
" LEICHTLINI MAJOR, a variety of large size, with flowers of a delicate French-white with an orange throat... ..	per doz., 1s. 9d.
" MIXED SEEDLINGS, useful for cutting	per 100, 7s.; per doz., 1s.

VICTORIA & PARADISE NURSERIES, UPPER HOLLOWAY, LONDON, N.

MR. J. C. STEVENS'

SALES BY AUCTION

OF

ESTABLISHED AND IMPORTED ORCHIDS

TAKE PLACE

EVERY WEEK AT HIS GREAT ROOMS,

38, KING STREET, COVENT GARDEN.

CATALOGUES FORWARDED ON RECEIPT OF TWO STAMPS.

SPECIAL NOTICE.—The price of the "Gardeners' Chronicle" is Threepence.

THE GARDENERS' CHRONICLE

("THE TIMES OF HORTICULTURE").

A Weekly Illustrated Journal

(ESTABLISHED 1841)

DEVOTED TO ALL BRANCHES OF GARDENING, FORESTRY, & RURAL PURSUITS.

EVERY FRIDAY, Price Threepence; Post Free to the Continent, Fourpence.

ALL SUBSCRIPTIONS PAYABLE IN ADVANCE.

THE UNITED KINGDOM: Twelve Months, 15s.; Six Months, 7s. 6d.; Three Months, 3s. 9d.; post free.

FOREIGN SUBSCRIPTIONS (excepting India and China): Including Postage, 17s. 6d. for Twelve Months. India and China, 19s. 6d.

P.O.O. to be made payable at The Post Office, 42, DRURY LANE, London, to W. RICHARDS.

W. RICHARDS, 41, WELLINGTON STREET, STRAND, LONDON.

MESSRS. PROTHEROE & MORRIS'S AUCTION SALES

ESTABLISHED & IMPORTED ORCHIDS

Take place Every Week at their

CENTRAL SALE ROOMS,
67 & 68, CHEAPSIDE, LONDON, E.C.

(Next door but one to Bennett's Clock).

CATALOGUES WILL BE FORWARDED ON APPLICATION.

CONTRACTORS TO HER MAJESTY'S WAR DEPARTMENT.

THE THAMES BANK IRON COMPANY,

(Telegraphic Address—"HOTWATER, LONDON." Telephone—No. 4,763.)

HAVE NOW PLEASURE IN BRINGING TO THE NOTICE OF HORTICULTURISTS AND GARDENERS GENERALLY THEIR

New Patent (No. 9090, 1888) Horizontal Tubular Boiler,

WHICH IS WITHOUT DOUBT THE BEST ALL-ROUND BOILER IN THE MARKET.

It combines all the advantages of its class so well known, and by the improved method of forming the joints, viz., with India Rubber Washers, the old and too often ineffectual way of caulking the joints is entirely dispensed with.

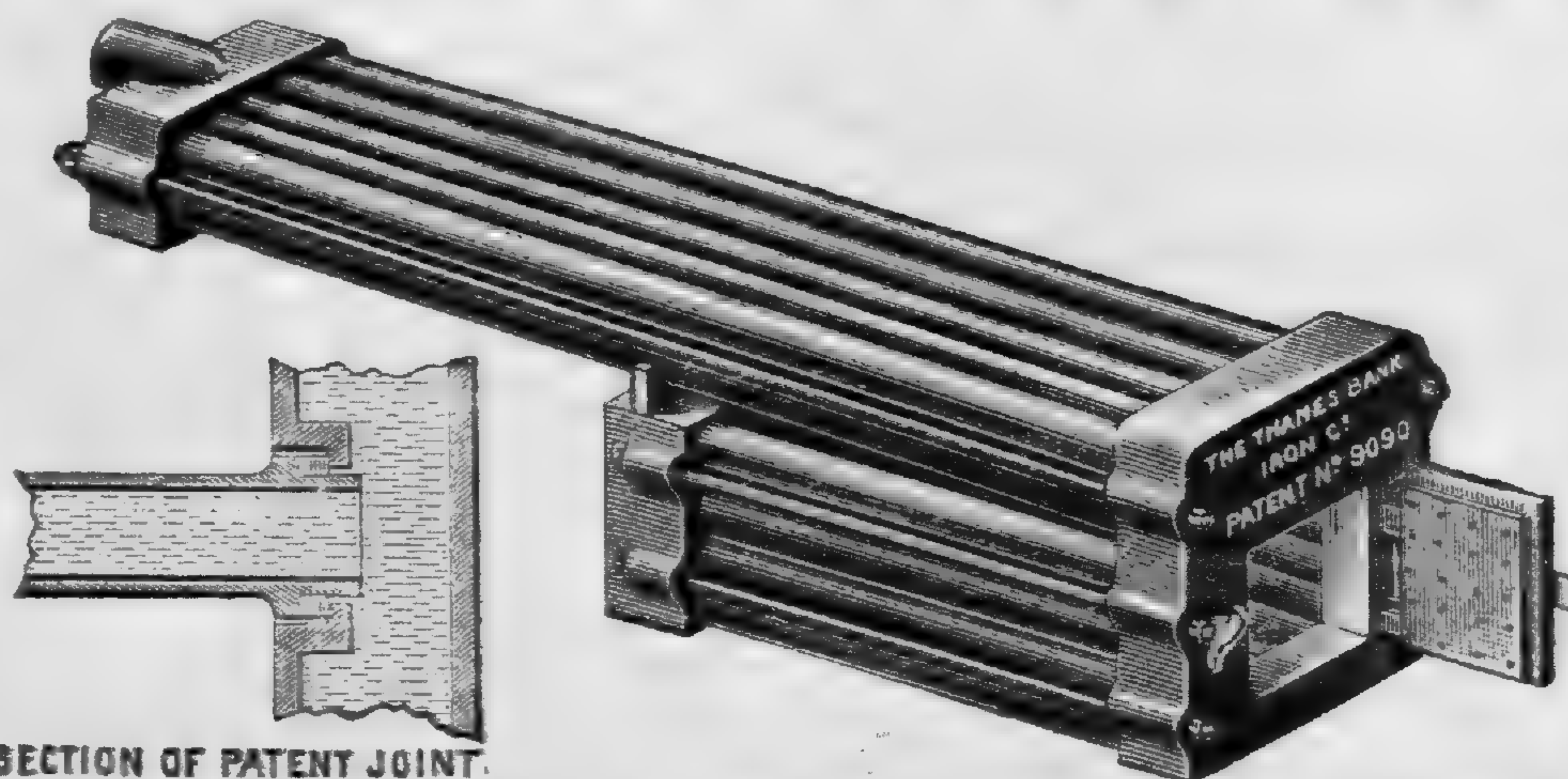

SECTION OF PATENT JOINT.

It can be erected in a few hours, and may be relied upon as a thoroughly sound and good Hot-water Generator. It has been carefully tested in every possible way, more especially with regard to power and durability, and the result has been highly satisfactory.

In the event of a Pipe requiring to be replaced, we have perfected an arrangement whereby same may be effected in the course of a FEW MINUTES, without the necessity of disturbing the brickwork setting.

THE LARGEST AND MOST COMPLETE STOCK OF
HOT-WATER BOILERS OF EVERY DESCRIPTION,
PIPES, CONNECTIONS, VALVES, VENTILATING GEAR, &c.

INSPECTION INVITED. PRICE LIST ON APPLICATION. ILLUSTRATED CATALOGUE, 1s.

UPPER GROUND STREET, BLACKFRIARS, LONDON, S.E.

VOL. IX.—PART 98.

MISSOURI
BOTANICAL
GARDEN.

PRICE, 5s.

THE
ORCHID ALBUM,

COMPRISING

COLOURED FIGURES AND DESCRIPTIONS
OF
NEW, RARE, AND BEAUTIFUL
ORCHIDACEOUS PLANTS.

CONDUCTED BY

ROBERT WARNER, F.L.S., F.R.H.S.,
AUTHOR OF SELECT ORCHIDACEOUS PLANTS,

AND

BENJAMIN SAMUEL WILLIAMS, F.L.S., F.R.H.S.,
AUTHOR OF THE ORCHID GROWERS' MANUAL, ETC.

THE COLOURED FIGURES BY JOHN NUGENT FITCH, F.L.S.

CONTENTS.

- PLATE 389. CYPRIPIEDIUM ARTHURIANUM.
" 390. ODONTOGLOSSUM CUSPIDATUM XANTHOGLOSSUM.
" 391. CYPRIPIEDIUM MACROPTERUM.
" 392. ONCIDIUM ANTHROCRENE.

LONDON:

PUBLISHED BY B. S. WILLIAMS,

AT THE

VICTORIA AND PARADISE NURSERIES, UPPER HOLLOWAY, N.

[All Rights Reserved.]

B. S. WILLIAMS'

SELECTION OF PLANTS

SUITABLE FOR

AUTUMN and WINTER FLOWERING and
EARLY FORCING.

NOW READY FOR DELIVERY.

	PER DOZ.
Acacia armata	12s. and 18s.
Andromeda floribunda	18s. ,, 30s.
Azalea indica (of sorts)	24s., 30s. ,, 42s.
" mollis (seedling)	15s., 18s., 30s. ,, 42s.
Begonias (winter-flowering)	18s. ,, 24s.
Bouvardias, including the new double scarlet,	18s. ,, 24s.
Camellias (of sorts)	30s. ,, 42s.
Carnations, Tree (of sorts)	18s. ,, 30s.
Citrus sinensis (with fruits)	42s. ,, 60s.
Cyclamen (of sorts)	24s. ,, 30s.
Daphne indica rubra	30s. ,, 42s.
Deutzia gracilis	18s. ,, 24s.
" crenata fl. pl. (in pots)	18s. ,, 30s.
" Pride of Rochester (from the ground)	18s. ,, 24s.
Epacris (of sorts)	24s. ,, 30s.
Epiphyllums (of sorts)	30s. ,, 42s.
Ericas (of sorts)	18s., 24s. ,, 30s.
Gardenias (of sorts)	24s. ,, 30s.
Hydrangea paniculata grandiflora... ..	12s. ,, 24s.
Jasminum grandiflorum	30s. ,, 42s.
Kalmia latifolia	30s. ,, 42s.
Laurustinus, nice compact heads... ..	18s. ,, 24s.
Lilac alba virginalis	42s.
" Charles X... ..	30s. ,, 42s.
" persica	30s. ,, 42s.
Primula sinensis alba plena	18s. ,, 24s.
" " Double (of sorts)	30s. ,, 42s.
Prunus sinensis alba plena	18s. ,, 30s.
Rhododendrons, Hardy, choice selection	24s. ,, 42s.
Roses, finest Teas and Hybrid Per- tuals, strong plants	30s. ,, 42s.
Solanum hybridum Empress, and others,	24s. ,, 30s.
Staphylea colchica	24s. ,, 30s.
Viburnum Opulus (Guelder Rose)	24s. ,, 30s.

B. S. WILLIAMS'

CHOICE SELECTION OF BULBS & ROOTS.

	PER DOZ.
Achimenes, choice selection	12s., 18s. and 30s.
Amaryllis, " " named kinds... ..	42s. ,, 105s.
" " " seedlings	30s. ,, 42s.
Begonias (Tuberous-rooted), choice named	30s. ,, 42s.
" " " unnamed, 12s., 18s. ,,	24s.
Dahlias (Single and Double), pot roots, 6s., 9s. ,,	12s.
Dielytra spectabilis, extra strong clumps	5s. ,, 9s.
Eucharis amazonica	24s. ,, 30s.
Gloriosa superba ... each, 5s. 0d.	
" Plantii	2s. 6d.
Gloxinias, choice named selection	18s., 24s. ,, 30s.
" Seedlings, good bulbs	12s. ,, 18s.
Helleborus niger (Christmas Rose)	15s., 18s. ,, 30s.
Hyacinthus candicans, per 100, 12s. 6d. and 20s. 2s. 6d. ,,	4s. 6d.
Lily of the Valley, imported clumps	12s. ,, 15s.
" " " single crowns, per 100, 6s.	
Spiræa japonica, strong clumps	5s. ,, 9s.
" astilboides " each, 3s. 6d.	
" aurea variegata, strong clumps, each, 1s.	9s.
" palmata, strong clumps... ..	9s. ,, 12s.
Vallota purpurea (Scarborough Lily)	18s. ,, 30s.

GLADIOLUS.

	PER DOZ.
Brenchleyensis, per 100, 5s. and 7s. 6d.	1s. 3d.
Colvilli, The Bride (the best for cutting)	1s. 6d.
English-grown Seedlings, per 100, 17s. 6d. and 21s.	2s. 6d.

LILIUMS.

	PER DOZ.
Auratum	12s., 18s., 30s. and 42s.
Candidum (home grown) ... per 100, 25s.	3s.
" (imported), per 100, 15s. and 20s.	3s.
Chalcedonicum	9s. ,, 12s.
Croceum	per 100, 21s. 3s.
Excelsum	15s.
Harrisii	10s., 15s., 18s., 24s., 30s. ,, 42s.
Lancifolium album	12s.
" roseum	7s. 6d.
" rubrum	7s. 6d.
Longiflorum	4s. 6d.
Martagon purpureum, purple... ..	5s. 6d.
" rubrum, scarlet	12s.
Tigrinum	per 100, 12s. 2s.

TUBEROSES.

	PER DOZ.
American, imported, ready in December, per 100, 25s.	4s.
Pearl, extra fine	4s. and 5s.
" Excelsior, very fine	5s. ,, 6s.

VICTORIA AND PARADISE NURSERIES,
UPPER HOLLOWAY, LONDON, N.

B. S. WILLIAMS'

Select List of Bulbs for Very Early Forcing.

HYACINTHS.

EARLY WHITE ROMAN (best quality)	per 100, 17s. 6d.	Per doz.—s. d.
NAMED HYACINTHS, specially selected for early forcing 2 6
		9s. & 12 0

The following are the best for very early forcing—

Albertine pure white	Norma deep blush
Alba maxima "	Tubiflora "
Blanchard "	Homerus deep rose
Crown Princess "	Rubra maxima "
La Tour d'Auvergne "	Grand Lilas... .. light blue
Elfrida blush	General Lauriston deep blue

EARLY SINGLE TULIPS.

	Per 100.	Per doz.		Per 100.	Per doz.
	s. d.	s. d.		s. d.	s. d.
Canary Bird, fine yellow	14 0	2 3	Duc Van Thol, yellow	12 6	1 9
Duc Van Thol, red and yellow	5 6	1 0	L'Immaculee, white	12 0	1 9
" " " gold striped	6 0	1 0	Le Matelas, rose	27 6	3 9
" " " rose	12 6	1 9	Pottebakker, white	14 0	2 3
" " " scarlet	6 0	0 9	Proserpine, deep rose	17 6	2 6
" " " white	17 6	2 6	Vermilion Brilliant, vermilion... ..	14 0	2 3

EARLY DOUBLE TULIPS.

	Per 100.	Per doz.		Per 100.	Per doz.
	s. d.	s. d.		s. d.	s. d.
Duc Van Thol, red and yellow... ..	3 6	0 8	Murillo, rosy white	12 6	1 9
Imperator rubrorum, crimson-scar-			Tournesol, red and yellow	10 0	1 6
let	15 0	2 3	" yellow	15 0	2 3

NARCISSUS.

	Per 100.	Per doz.		Per 100.	Per doz.
	s. d.	s. d.		s. d.	s. d.
Double Roman	8 0	1 6	Poeticus flore pleno	6 6	1 0
Paper White	8 0	1 6	" ornatus	10 6	1 9
EARLY PAPER WHITE, large-flowering. Flowers stronger and earlier than the old variety				10 6	1 3

LILIUM HARRISII

(The Bermuda Easter Lily).

STRONG BULBS	10s., 15s., 18s., 24s. & 30s. per doz.
EXTRA STRONG BULBS	3s. 6d. each.
FREESIA REFRACTA ALBA	per 100, 10s.; per doz., 1s. 9d
" LEICHTLINI MAJOR, a variety of large size, with flowers of a delicate French-white with	
an orange throat... ..	per doz., 1s. 9d.
" MIXED SEEDLINGS, useful for cutting	per 100, 7s.; per doz., 1s.

VICTORIA & PARADISE NURSERIES, UPPER HOLLOWAY, LONDON, N.

MR. J. C. STEVENS'

SALES BY AUCTION

OF

ESTABLISHED AND IMPORTED ORCHIDS

TAKE PLACE

EVERY WEEK AT HIS GREAT ROOMS,

38, KING STREET, COVENT GARDEN.

CATALOGUES FORWARDED ON RECEIPT OF TWO STAMPS.

SPECIAL NOTICE.—The price of the "Gardeners' Chronicle" is Threepence.

THE GARDENERS' CHRONICLE

("THE TIMES OF HORTICULTURE").

A Weekly Illustrated Journal

(ESTABLISHED 1841)

DEVOTED TO ALL BRANCHES OF GARDENING, FORESTRY, & RURAL PURSUITS.

EVERY FRIDAY, Price Threepence; Post Free to the Continent, Fourpence.

ALL SUBSCRIPTIONS PAYABLE IN ADVANCE.

THE UNITED KINGDOM: Twelve Months, 15s.; Six Months, 7s. 6d.; Three Months, 3s. 9d.; post free.

FOREIGN SUBSCRIPTIONS (excepting India and China): Including Postage, 17s. 6d. for Twelve Months. India and China, 19s. 6d.

P.O.O. to be made payable at The Post Office, 42, DRURY LANE, London, to W. RICHARDS.

W. RICHARDS, 41, WELLINGTON STREET, STRAND, LONDON.

MESSRS. PROTHEROE & MORRIS'S

AUCTION SALES

ESTABLISHED & IMPORTED ORCHIDS

Take place Every Week at their

CENTRAL SALE ROOMS,

67 & 68, CHEAPSIDE, LONDON, E.C.

(Next door but one to Bennett's Clock).

CATALOGUES WILL BE FORWARDED ON APPLICATION.

CONTRACTORS TO HER MAJESTY'S WAR DEPARTMENT.

THE THAMES BANK IRON COMPANY,

(Telegraphic Address—"HOTWATER, LONDON." Telephone—No. 4,763.)

HAVE NOW PLEASURE IN BRINGING TO THE NOTICE OF HORTICULTURISTS AND GARDENERS GENERALLY THEIR

"CHAMPION" Horizontal Tubular Boiler (PATENT No. 9090.)

WHICH IS WITHOUT DOUBT THE BEST ALL-ROUND BOILER IN THE MARKET.

It combines all the advantages of its class so well known, and by the improved method of forming the joints, viz., with India Rubber Washers, the old and too often ineffectual way of caulking the joints is entirely dispensed with.

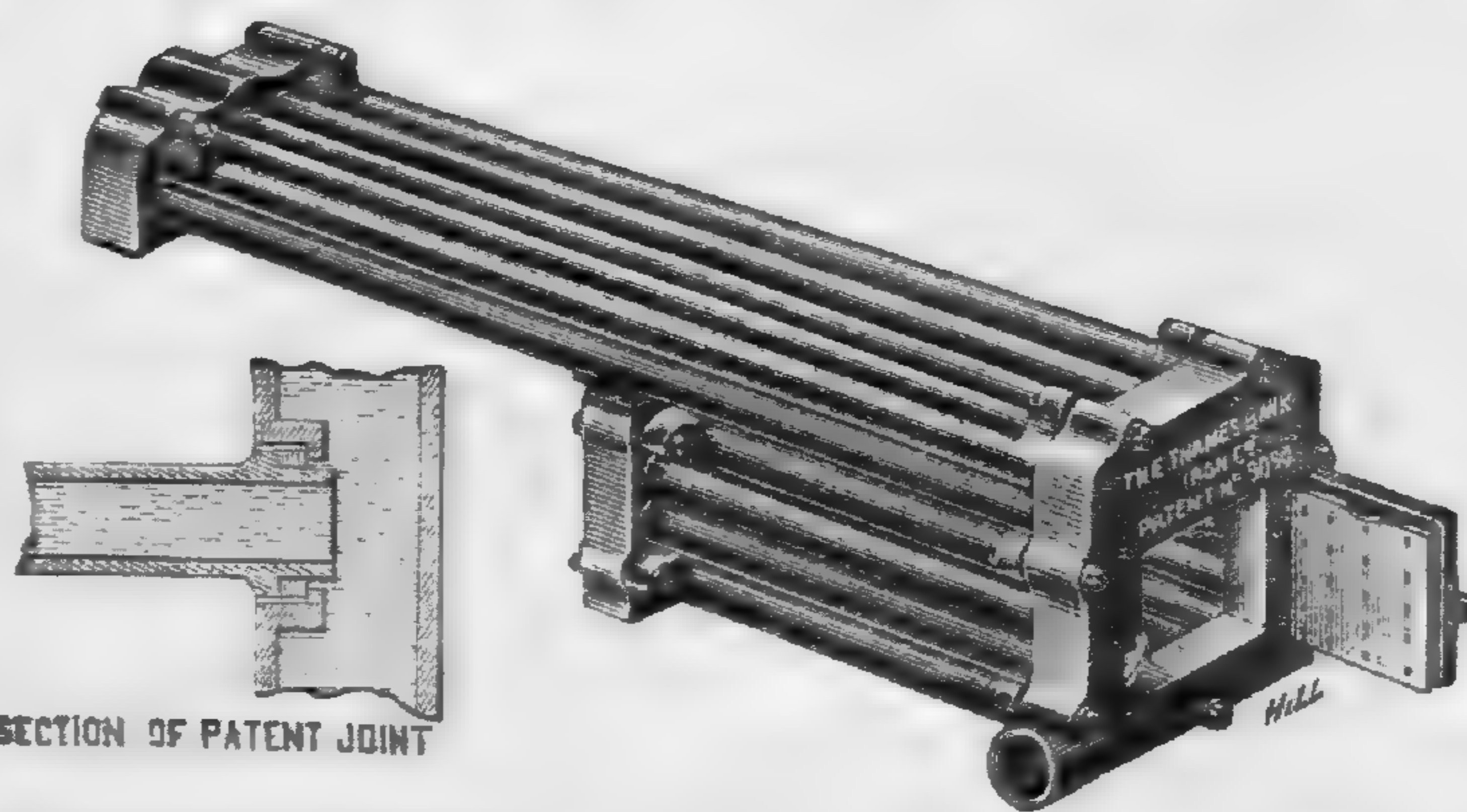

It can be erected in a few hours, and may be relied upon as a thoroughly sound and good Hot-water Generator. It has been carefully tested in every possible way, more especially with regard to power and durability, and the result has been highly satisfactory.

In the event of a Pipe requiring to be replaced, we have perfected an arrangement whereby same may be effected in the course of a FEW MINUTES, without the necessity of disturbing the brickwork setting.

THE LARGEST AND MOST COMPLETE STOCK OF

HOT-WATER BOILERS OF EVERY DESCRIPTION,

PIPES, CONNECTIONS, VALVES, VENTILATING GEAR, &c.

INSPECTION INVITED. PRICE LIST ON APPLICATION. ILLUSTRATED CATALOGUE, 1s.

UPPER GROUND STREET, BLACKFRIARS, LONDON, S.E.

VOL. IX.—PART 99.

MISSOURI
BOTANICAL
GARDEN.

PRICE, 5s.

THE
ORCHID ALBUM,

COMPRISING

COLOURED FIGURES AND DESCRIPTIONS

OF

NEW, RARE, AND BEAUTIFUL

ORCHIDACEOUS PLANTS.

CONDUCTED BY

ROBERT WARNER, F.L.S., F.R.H.S.,

AUTHOR OF SELECT ORCHIDACEOUS PLANTS,

AND

BENJAMIN SAMUEL WILLIAMS, F.L.S., F.R.H.S.,

AUTHOR OF THE ORCHID GROWERS' MANUAL, ETC.

THE COLOURED FIGURES BY JOHN NUGENT FITCH, F.L.S.

CONTENTS.

- PLATE 393. LÆLIA ELEGANS BLENHEIMENSE.
" 394. PESCATORIA CERINA.
" 395. LÆLIA MONOPHYLLA.
" 396. DENDROBIUM TRANSPARENS.

LONDON:

PUBLISHED BY B. S. WILLIAMS & SON,

AT THE

VICTORIA AND PARADISE NURSERIES, UPPER HOLLOWAY, N.

[All Rights Reserved.]

B. S. WILLIAMS & SON'S

SELECTION OF PLANTS

SUITABLE FOR

WINTER FLOWERING AND EARLY
FORCING.

NOW READY FOR DELIVERY.

	PER DOZ.
Acacia armata	12s. and 18s.
Andromeda floribunda	18s. ,, 30s.
Azalea indica (of sorts)	24s., 30s. ,, 42s.
" mollis (seedling)	15s., 18s., 30s. ,, 42s.
Begonias (winter-flowering)	18s. ,, 24s.
Bouvardias, including the new double scarlet,	18s. ,, 24s.
Camellias (of sorts)	30s. ,, 42s.
Carnations, Tree (of sorts)	18s. ,, 30s.
Citrus sinensis (with fruits)	42s. ,, 60s.
Cyclamen (of sorts)	24s. ,, 30s.
Daphne indica rubra	30s. ,, 42s.
Deutzia gracilis	18s. ,, 24s.
" crenata fl. pl. (in pots)	18s. ,, 30s.
" Pride of Rochester (from the ground)	18s. ,, 24s.
Epacris (of sorts)	24s. ,, 30s.
Epiphyllums (of sorts)	30s. ,, 42s.
Ericas (of sorts)	18s., 24s. ,, 30s.
Gardenias (of sorts)	24s. ,, 30s.
Hydrangea paniculata grandiflora... ..	12s. ,, 24s.
Jasminum grandiflorum	30s. ,, 42s.
Kalmia latifolia	30s. ,, 42s.
Laurustinus, nice compact heads... ..	18s. ,, 24s.
Lilac alba virginalis	42s.
" Charles X.... ..	30s. ,, 42s.
" persica	30s. ,, 42s.
Primula sinensis alba plena	18s. ,, 24s.
" " Double (of sorts)	30s. ,, 42s.
Prunus sinensis alba plena	18s. ,, 30s.
Rhododendrons, Hardy, choice selection	24s. ,, 42s.
Roses, finest Teas and Hybrid Per- petuals, strong plants	30s. ,, 42s.
Solanum hybridum Empress, and others,	24s. ,, 30s.
Staphylea colchica	24s. ,, 30s.
Viburnum opulus (Guelder Rose)	24s. ,, 30s.

B. S. WILLIAMS & SON'S

CHOICE SELECTION OF BULBS & ROOTS.

	PER DOZ.
Achimenes, choice selection	12s., 18s. and 30s.
Amaryllis, " " named kinds... ..	42s. ,, 105s.
" " " seedlings	30s. ,, 42s.
Begonias (Tuberous-rooted), choice named	30s. ,, 42s.
" " " unnamed, 12s., 18s. ,,	24s.
Dahlias (Single and Double), pot roots, 6s., 9s. ,,	12s.
Dielytra spectabilis, extra strong clumps	5s. ,, 9s.
Eucharis amazonica	24s. ,, 30s.
Gloriosa superba each, 5s. 0d.	
" Plantii	2s. 6d.
Gloxinias, choice named selection	18s., 24s. ,, 30s.
" Seedlings, good bulbs	12s. ,, 18s.
Helleborus niger (Christmas Rose)	15s., 18s. ,, 30s.
Hyacinthus candicans, per 100, 12s. 6d. and 20s. 2s. 6d. ,,	4s. 6d.
Lily of the Valley, imported clumps	12s. ,, 15s.
" " " single crowns, per 100, 6s.	
Spiræa japonica, strong clumps	5s. ,, 9s.
" astiloides " each, 3s. 6d.	
" aurea variegata, strong clumps, each, 1s.	9s.
" palmata, strong clumps... ..	9s. ,, 12s.
Vallota purpurea (Scarborough Lily)	18s. ,, 30s.

GLADIOLUS.

	PER DOZ.
Brenchleyensis, per 100, 5s. and 7s. 6d.	1s. 3d.
Colvilli, The Bride (the best for cutting) per 100, 8s.	1s. 6d.
English-grown Seedlings, per 100, 17s. 6d. and 21s.	2s. 6d.
Mixed Hardy Spotted Hybrids, per 100, 35s.	

LILIUMS.

	PER DOZ.
Auratum	12s., 18s., 30s. and 42s.
Candidum (home grown)	per 100, 25s. 3s.
" (imported), per 100, 15s. and 20s.	3s.
Chalcedonicum	9s. ,, 12s.
Croceum	per 100, 21s. 3s.
Excelsum	15s.
Harrisii	10s., 15s., 18s., 24s., 30s. ,, 42s.
Lancifolium album	12s.
" roseum	7s. 6d.
" rubrum	7s. 6d.
Longiflorum	4s. 6d.
Martagon purpureum, purple... ..	5s. 6d.
" rubrum, scarlet	12s.
Tigrinum	per 100, 12s. 2s.

TUBEROSES.

	PER DOZ.
American, imported, ready in December, per 100, 25s.	4s.
Pearl, extra fine	4s.
" Excelsior, very fine	5s.

VICTORIA AND PARADISE NURSERIES,
UPPER HOLLOWAY, LONDON, N.

B. S. WILLIAMS & SON'S NOVELTIES IN SEEDS, &C., FOR 1890.

Sold only in Sealed Packets bearing our Trade Mark.

NEW ORNAMENTAL-LEAVED BEET.

(McGregor's Favourite.)

Awarded First Class Certificate by the Royal Horticultural Society, September 25th, 1888. This attractive and beautiful variety of Beet is quite a distinct and new departure, and will prove a great acquisition in the Flower Garden. It is very effective when used in ribbon borders, &c. It may also be grown as a pot plant, and used for table decoration. The leaves are of a rich bronzy crimson colour, narrow, arching, about 6 to 8 inches long, and fold inwards, resembling in habit a narrow-leaved *Dracaena*.

Per packet, 1s.

PRIMULA SINENSIS FIMBRIATA, "EMPRESS."

This is a very fine semi-double variety, similar in habit and constitution to *Firefly*. The colour is a delicate pink of a pleasing tone. It is very suitable for conservatory decoration.

Per packet, 3s. 6d.

PRIMULA SINENSIS FIMBRIATA, "FIREFLY."

This is a beautiful semi-double variety, of very robust and vigorous constitution. The habit of the plant is very fine and symmetrical, and it is exceedingly free flowering. The colour is of a deep crimson, somewhat more intense in shade than *Meteor*. It comes very true from seed, and will be found most serviceable for conservatory decoration.

Per packet, 3s. 6d.

GLOXINIA "GOUVILLE" STRAIN.

We have much pleasure in being able to offer, through the kindness of the Comte de Germiny, seeds of this splendid strain, which has the reputation of being the finest on the Continent. It invariably takes First Prizes wherever exhibited. The flowers are of immense size and substance, of very brilliant and varied colour, beautifully tигged and spotted, and contain a fair proportion of self colours.

Per packet, 2s. 6d.

EARLEYS' HARDY CURLED SPROUT.

This new variety was raised by Mr. William Earley, the well-known horticulturist of Ilford, from whom we have purchased the entire stock, who describes it as follows:—"A cross between the *Brussels Sprouts* and *Kale, Scotch Curled*. The latter was crossed with Brussels Sprout pollen. This has produced a robust variety with true Brussels Sprout habit, the foliage being midway between the two parents; the sprouts also partake of the curled habit of the seed-bearing parent. It is extremely hardy, carrying its robust, green foliage until late spring, and is destined to fill up the gap (often a large one) between late Brussels Sprouts and early Summer Cabbage. Being devoid of the roughness of Scotch Kale when cooked, and entirely free from the strong taste of Brussels Sprouts, its flavour is peculiarly original and pleasing. The thick-stalked dense crowns add very materially to its merits." Seeds now offered were grown direct from the plants produced by the cross-fertilised pod.

Per packet, 2s. 6d.

THE NEW GLADIOLI, "SNOW-WHITE."

The raiser describes it as follows:—"It is the best white Gladiolus ever grown. The flowers are well formed, and have a paper whiteness we have never seen in any other sort. The flowers are of exceptional substance, lasting a remarkable length of time when cut. Every bloom on the spike can be used individually for cut-flower work. The spikes are of good size, set solidly and perfect, with the florets from bottom to top. The petals are gracefully recurved, and, in many cases, beautifully crisped. Under ordinary circumstances nearly the entire flower is a perfect paper-white, with a slight cream shade on lower half of the lower petal. A faint line of purple extends about half-way through the lower petal. For withstanding dews, rains, and hot sunshine without changing colour, we have never seen its equal. It is not good one week and stained with pink and purple the next, like all the other light-coloured Gladioli we have ever seen. It comes just the same each year, and week after week."

Per doz., 21s.; each, 2s.

Illustrated Seed Catalogue for 1890, now ready, gratis and post free.

VICTORIA & PARADISE NURSERIES, UPPER HOLLOWAY, LONDON, N.

MR. J. C. STEVENS'

SALES BY AUCTION

OF

ESTABLISHED AND IMPORTED ORCHIDS

TAKE PLACE

EVERY WEEK AT HIS GREAT ROOMS,

38, KING STREET, COVENT GARDEN.

CATALOGUES FORWARDED ON RECEIPT OF TWO STAMPS.

SPECIAL NOTICE.—The price of the "Gardeners' Chronicle" is Threepence.

THE GARDENERS' CHRONICLE

("THE TIMES OF HORTICULTURE").

A Weekly Illustrated Journal

(ESTABLISHED 1841)

DEVOTED TO ALL BRANCHES OF GARDENING, FORESTRY, & RURAL PURSUITS.

EVERY FRIDAY, Price Threepence; Post Free to the Continent, Fourpence.

ALL SUBSCRIPTIONS PAYABLE IN ADVANCE.

THE UNITED KINGDOM: Twelve Months, 15s.; Six Months, 7s. 6d.; Three Months, 3s. 9d.; post free.

FOREIGN SUBSCRIPTIONS (excepting India and China): Including Postage, 17s. 6d. for Twelve Months. India and China, 19s. 6d.

P.O.O. to be made payable at The Post Office, 42, DRURY LANE, London, to W. RICHARDS.

W. RICHARDS, 41, WELLINGTON STREET, STRAND, LONDON.

MESSRS. PROTHEROE & MORRIS'S AUCTION SALES

ESTABLISHED & IMPORTED ORCHIDS

Take place Every Week at their

CENTRAL SALE ROOMS,
67 & 68, CHEAPSIDE, LONDON, E.C.

(Next door but one to Bennett's Clock).

CATALOGUES WILL BE FORWARDED ON APPLICATION.

CONTRACTORS TO HER MAJESTY'S WAR DEPARTMENT.

THE THAMES BANK IRON COMPANY,

(Telegraphic Address—"HOTWATER, LONDON." Telephone—No. 4,763.)

HAVE NOW PLEASURE IN BRINGING TO THE NOTICE OF HORTICULTURISTS AND GARDENERS GENERALLY THEIR

"CHAMPION" Horizontal Tubular Boiler (PATENT No. 9090.)

WHICH IS WITHOUT DOUBT THE BEST ALL-ROUND BOILER IN THE MARKET.

It combines all the advantages of its class so well known, and by the improved method of forming the joints, viz., with India Rubber Washers, the old and too often ineffectual way of caulking the joints is entirely dispensed with.

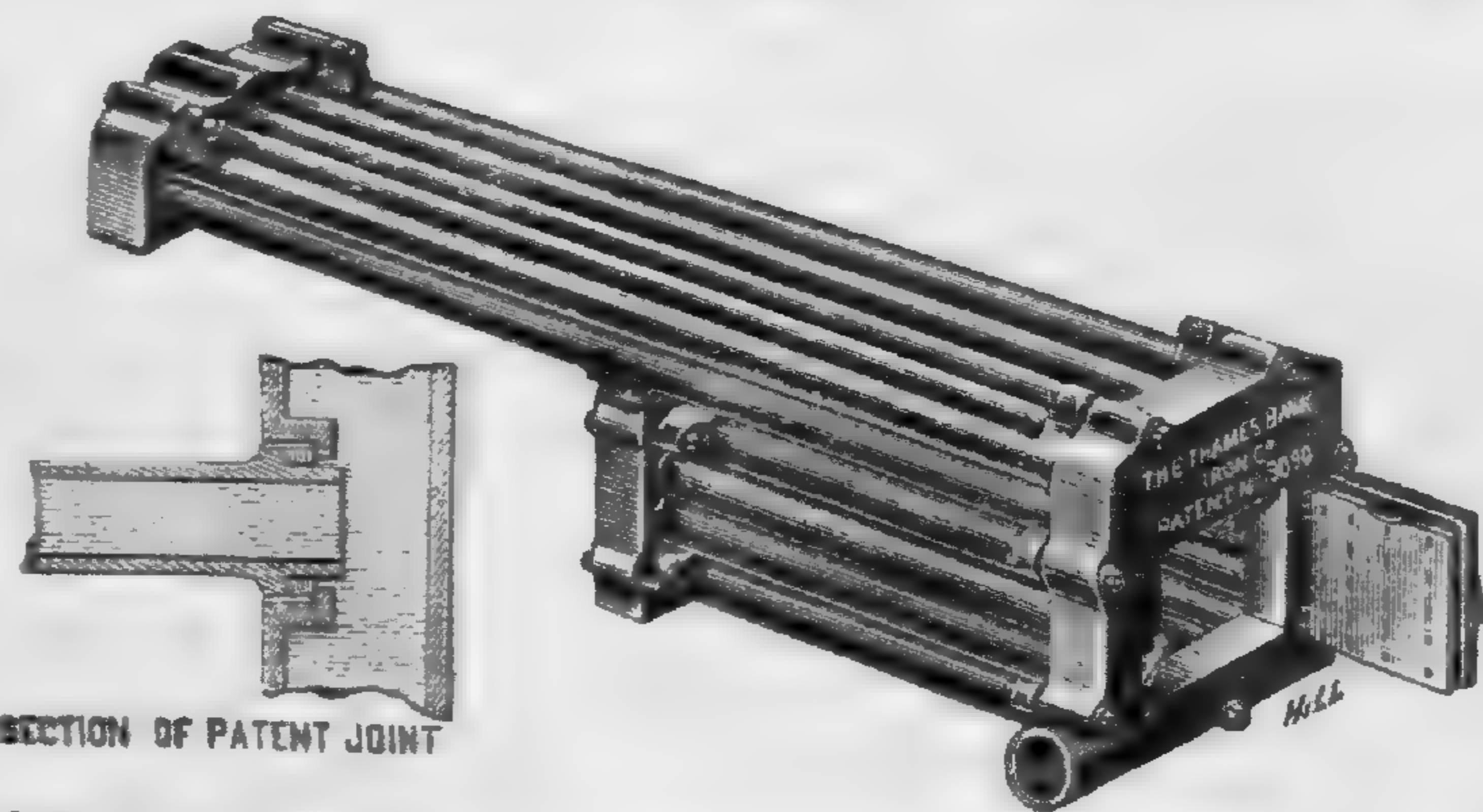

It can be erected in a few hours, and may be relied upon as a thoroughly sound and good Hot-water Generator. It has been carefully tested in every possible way, more especially with regard to power and durability, and the result has been highly satisfactory.

In the event of a Pipe requiring to be replaced, we have perfected an arrangement whereby same may be effected in the course of a FEW MINUTES, without the necessity of disturbing the brickwork setting.

THE LARGEST AND MOST COMPLETE STOCK OF
HOT-WATER BOILERS OF EVERY DESCRIPTION,
PIPES, CONNECTIONS, VALVES, VENTILATING GEAR, &c.

INSPECTION INVITED.

PRICE LIST ON APPLICATION.

ILLUSTRATED CATALOGUE, 1s.

UPPER GROUND STREET, BLACKFRIARS, LONDON, S.E.

VOL. IX.—PART 100.

MISSOURI
BOTANICAL

PRICE, 5s.

THE
ORCHID ALBUM,

COMPRISING

COLOURED FIGURES AND DESCRIPTIONS
OF
NEW, RARE, AND BEAUTIFUL
ORCHIDACEOUS PLANTS.

CONDUCTED BY

ROBERT WARNER, F.L.S., F.R.H.S.,
AUTHOR OF SELECT ORCHIDACEOUS PLANTS,

AND

BENJAMIN SAMUEL WILLIAMS, F.L.S., F.R.H.S.,
AUTHOR OF THE ORCHID GROWERS' MANUAL, ETC.

THE COLOURED FIGURES BY JOHN NUGENT FITCH, F.L.S.

CONTENTS.

- PLATE 397. CYPRIPIEDIUM ELLIOTTIANUM.
„ 398. DENDROBIUM BRYMERIANUM.
„ 399. DISA GRAMINÆFOLIA.
„ 400. CYPRIPIEDIUM ASHBURTONIÆ SUPERBUM.

LONDON:

PUBLISHED BY B. S. WILLIAMS & SON,

AT THE

VICTORIA AND PARADISE NURSERIES, UPPER HOLLOWAY, N.

[All Rights Reserved.]

CASES FOR BINDING the Volumes of this Work can be supplied, PRICE 3s. 6d. EACH,
ALL BACK PARTS KEPT IN STOCK.

FOR THE VILLA GARDEN, COUNTRY HOUSE, KITCHEN GARDEN,
ORCHARD, FLOWER SHOW, AND NURSERY.

EVERY SATURDAY, TWOPENCE.

Subscription 11s. 6d. per Annum, Post Free.

THE

GARDENERS' MAGAZINE.

FOR

*Amateur Cultivators, Collectors, and Exhibitors of Plants, Flowers, and Fruits; for
Gentlemen's Gardeners, Florists, Nurserymen, Seedsmen, &c.*

CONDUCTED BY

SHIRLEY HIBBERD, F.R.H.S.

Contains Original Articles by the most eminent practical Horticulturists on the Selection and Cultivation of Flowers, Fruits, and Vegetables; on the Principles of Taste in Designing and Embellishing Gardens; and on the Progress of Horticulture generally. Also Reports of Flower Shows, Descriptions of New Plants, and every matter of importance to Amateurs and Professional Gardeners.

THE LATEST GARDEN NEWS, THE MOST ORIGINAL INFORMATION, AND MOST IMPARTIAL
REFLECTION OF GARDEN AFFAIRS.

PUBLISHING OFFICE: 4, AVE MARIA LANE, LONDON, E.C.

WILLIAMS' ORCHID-GROWERS' SUNDRIES.

BEST SELECTED FIBROUS PEAT FOR ORCHIDS.

10s. 6d. per sack, 21s. and 42s. per crate.

FRESH SPHAGNUM MOSS FOR ORCHIDS.

3s. per bushel, 12s. per sack.

OCTAGONAL TEAK-WOOD ORCHID BASKETS.

These Baskets, which are in increasing demand among Orchid Growers, are well made with the best quality *Octagonal* Teak Rods, fastened with Copper Wire. They are ordinarily made square, but can be had in Cylindrical, Boat, or Raft shapes. They are elegant in appearance, strong, and durable.

Outside Measure of Basket,	With Copper Wire, Nails, and Suspenders. Per doz.—s. d.	Outside Measure of Basket.	With Copper Wire, Nails, and Suspenders. Per doz.—s. d.	Per inch run
3 inches	6 0	8 inches	16 0	Rafts ... 1d.
4 "	8 0	9 "	18 0	Boats ... 1½d.
5 "	10 0	10 "	21 0	Cylinders ... 2d.
6 "	12 0	11 "	23 0	
7 "	14 0	12 "	26 0	

Special Shapes and Sizes made to order.

WILLIAMS' ORCHID PANS.

These Pans are well adapted and highly recommended for growing Orchids in, suspended from the roof, and are a good substitute for wooden baskets and blocks. The Pans, as sold, have holes bored in the side for attaching the wires to.

Diameter.	Per doz.—s. d.	Diameter.	Per doz.—s. d.	Diameter.	Per doz.—s. d.
2 inches...	1 0	3½ inches...	1 9	6 inches ...	4 0
2½ "	1 3	4 "	2 3	7 "	5 0
3 "	1 6	5 "	3 0	8 "	6 0

B. S. WILLIAMS & SON,
VICTORIA AND PARADISE NURSERIES,
UPPER HOLLOWAY, LONDON, N.

B. S. WILLIAMS & SON'S NOVELTIES IN SEEDS, &C., FOR 1890.

Sold only in Sealed Packets bearing our Trade Mark.

NEW ORNAMENTAL-LEAVED BEET.

(McGregor's Favourite.)

Awarded First Class Certificate by the Royal Horticultural Society, September 25th, 1888. This attractive and beautiful variety of Beet is quite a distinct and new departure, and will prove a great acquisition in the Flower Garden. It is very effective when used in ribbon borders, &c. It may also be grown as a pot plant, and used for table decoration. The leaves are of a rich bronzy crimson colour, narrow, arching, about 6 to 8 inches long, and fold inwards, resembling in habit a narrow-leaved *Dracæna*.

Per packet, 1s.

PRIMULA SINENSIS FIMBRIATA, "EMPRESS."

This is a very fine semi-double variety, similar in habit and constitution to *Firefly*. The colour is a delicate pink of a pleasing tone. It is very suitable for conservatory decoration.

Per packet, 3s. 6d.

PRIMULA SINENSIS FIMBRIATA, "FIREFLY."

This is a beautiful semi-double variety, of very robust and vigorous constitution. The habit of the plant is very fine and symmetrical, and it is exceedingly free flowering. The colour is of a deep crimson, somewhat more intense in shade than *Meteor*. It comes very true from seed, and will be found most serviceable for conservatory decoration.

Per packet, 3s. 6d.

GLOXINIA "GOUVILLE" STRAIN.

We have much pleasure in being able to offer, through the kindness of the Comte de Germiny, seeds of this splendid strain, which has the reputation of being the finest on the Continent. It invariably takes First Prizes wherever exhibited. The flowers are of immense size and substance, of very brilliant and varied colour, beautifully tигed and spotted, and contain a fair proportion of self colours.

Per packet, 2s. 6d.

EARLEYS' HARDY CURLED SPROUT.

This new variety was raised by Mr. William Earley, the well-known horticulturist of Ilford, from whom we have purchased the entire stock, who describes it as follows:—"A cross between the *Brussels Sprouts* and *Kale, Scotch Curled*. The latter was crossed with Brussels Sprout pollen. This has produced a robust variety with true Brussels Sprout habit, the foliage being midway between the two parents; the sprouts also partake of the curled habit of the seed-bearing parent. It is extremely hardy, carrying its robust, green foliage until late spring, and is destined to fill up the gap (often a large one) between late Brussels Sprouts and early Summer Cabbage. Being devoid of the roughness of Scotch Kale when cooked, and entirely free from the strong taste of Brussels Sprouts, its flavour is peculiarly original and pleasing. The thick-stalked dense crowns add very materially to its merits." Seeds now offered were grown direct from the plants produced by the cross-fertilised pod.

Per packet, 2s. 6d.

THE NEW GLADIOLI, "SNOW-WHITE."

The raiser describes it as follows:—"It is the best white Gladiolus ever grown. The flowers are well formed, and have a paper whiteness we have never seen in any other sort. The flowers are of exceptional substance, lasting a remarkable length of time when cut. Every bloom on the spike can be used individually for cut-flower work. The spikes are of good size, set solidly and perfect, with the florets from bottom to top. The petals are gracefully recurved, and, in many cases, beautifully crisped. Under ordinary circumstances nearly the entire flower is a perfect paper-white, with a slight cream shade on lower half of the lower petal. A faint line of purple extends about half-way through the lower petal. For withstanding dews, rains, and hot sunshine without changing colour, we have never seen its equal. It is not good one week and stained with pink and purple the next, like all the other light-coloured Gladioli we have ever seen. It comes just the same each year, and week after week."

Per doz., 21s.; each, 2s.

Illustrated Seed Catalogue for 1890, now ready, gratis and post free.

VICTORIA & PARADISE NURSERIES, UPPER HOLLOWAY, LONDON, N.

MR. J. C. STEVENS'

SALES BY AUCTION

OF

ESTABLISHED AND IMPORTED ORCHIDS

TAKE PLACE

EVERY WEEK AT HIS GREAT ROOMS,

38, KING STREET, COVENT GARDEN.

CATALOGUES FORWARDED ON RECEIPT OF TWO STAMPS.

SPECIAL NOTICE.—The price of the "Gardeners' Chronicle" is Threepence.

THE GARDENERS' CHRONICLE

("THE TIMES OF HORTICULTURE").

A Weekly Illustrated Journal

(ESTABLISHED 1841)

DEVOTED TO ALL BRANCHES OF GARDENING, FORESTRY, & RURAL PURSUITS.

EVERY FRIDAY, Price Threepence; Post Free to the Continent, Fourpence.

ALL SUBSCRIPTIONS PAYABLE IN ADVANCE.

THE UNITED KINGDOM: Twelve Months, 15s.; Six Months, 7s. 6d.; Three Months, 3s. 9d.; post free.

FOREIGN SUBSCRIPTIONS (excepting India and China): Including Postage, 17s. 6d. for Twelve Months. India and China, 19s. 6d.

P.O.O. to be made payable at The Post Office, 42, DRURY LANE, London, to W. RICHARDS.

W. RICHARDS, 41, WELLINGTON STREET, STRAND, LONDON.

MESSRS. PROTHEROE & MORRIS'S

AUCTION SALES

ESTABLISHED & IMPORTED ORCHIDS

Take place Every Week at their

CENTRAL SALE ROOMS,

67 & 68, CHEAPSIDE, LONDON, E.C.

(Next door but one to Bennett's Clock).

CATALOGUES WILL BE FORWARDED ON APPLICATION.

CONTRACTORS TO HER MAJESTY'S WAR DEPARTMENT.

THE THAMES BANK IRON COMPANY,

(Telegraphic Address—"HOTWATER, LONDON." Telephone—No. 4,763.)

HAVE NOW PLEASURE IN BRINGING TO THE NOTICE OF HORTICULTURISTS AND GARDENERS GENERALLY THEIR

"CHAMPION" Horizontal Tubular Boiler (PATENT No. 9090.)

WHICH IS WITHOUT DOUBT THE BEST ALL-ROUND BOILER IN THE MARKET.

It combines all the advantages of its class so well known, and by the improved method of forming the joints, viz., with India Rubber Washers, the old and too often ineffectual way of caulking the joints is entirely dispensed with.

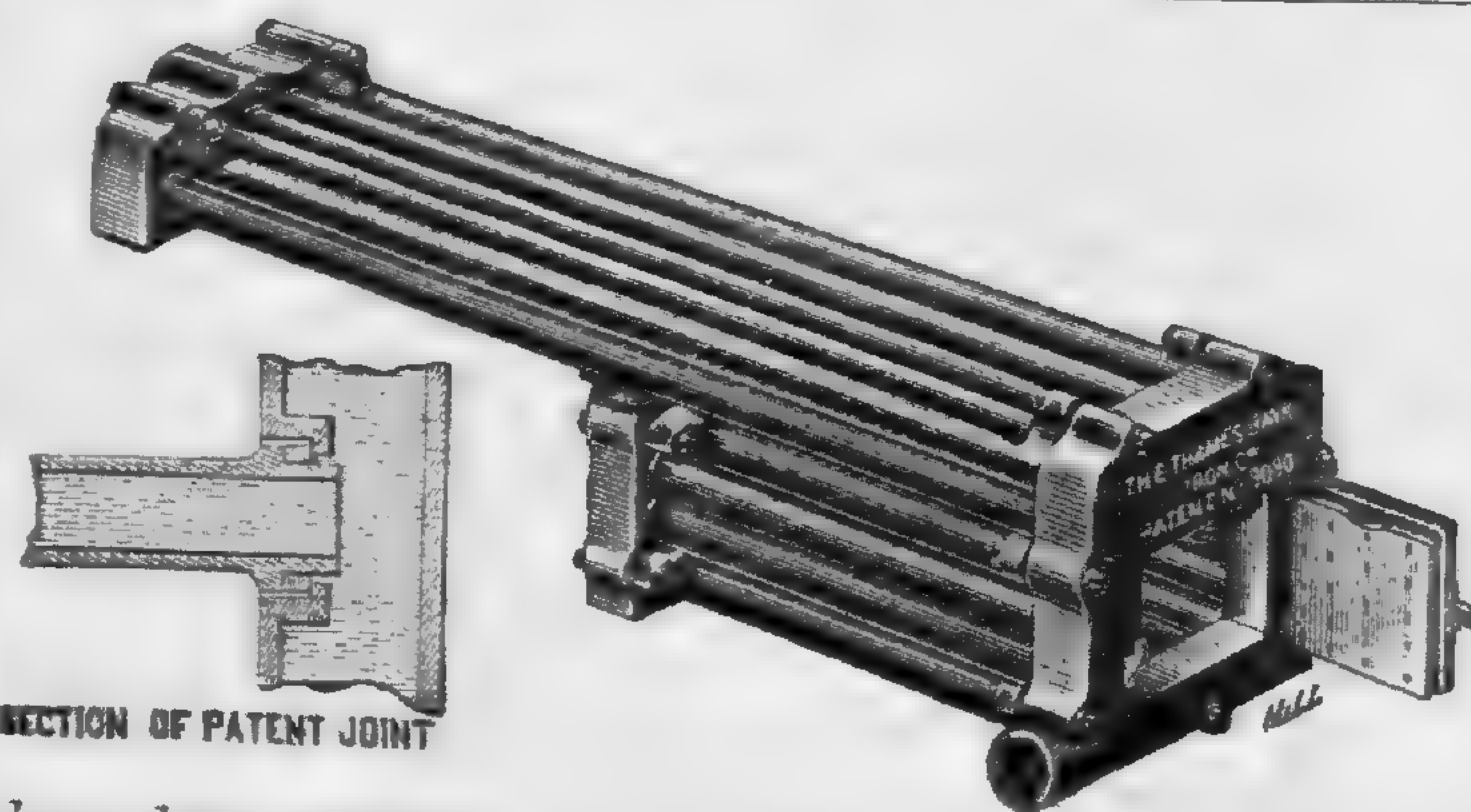

It can be erected in a few hours, and may be relied upon as a thoroughly sound and good Hot-water Generator. It has been carefully tested in every possible way, more especially with regard to power and durability, and the result has been highly satisfactory.

In the event of a Pipe requiring to be replaced, we have perfected an arrangement whereby same may be effected in the course of a FEW MINUTES, without the necessity of disturbing the brickwork setting.

THE LARGEST AND MOST COMPLETE STOCK OF

HOT-WATER BOILERS OF EVERY DESCRIPTION,

PIPES, CONNECTIONS, VALVES, VENTILATING GEAR, &c.

INSPECTION INVITED.

PRICE LIST ON APPLICATION.

ILLUSTRATED CATALOGUE, 1s.

UPPER GROUND STREET, BLACKFRIARS, LONDON, S.E.

Missouri Botanical Garden
St Louis Missouri

VOL. IX.—PART 101.

BOTANICAL
GARDEN

PRICE, 5s.

THE
ORCHID ALBUM,

COMPRISING

COLOURED FIGURES AND DESCRIPTIONS

OF

NEW, RARE, AND BEAUTIFUL

ORCHIDACEOUS PLANTS.

CONDUCTED BY

ROBERT WARNER, F.L.S., F.R.H.S.,

AUTHOR OF SELECT ORCHIDACEOUS PLANTS,

AND

BENJAMIN SAMUEL WILLIAMS, F.L.S., F.R.H.S.,

AUTHOR OF THE ORCHID GROWERS' MANUAL, ETC.

THE COLOURED FIGURES BY JOHN NUGENT FITCH, F.L.S.

CONTENTS.

- PLATE 401. LÆLIA DORMANIANA.
" 402. CALANTHE MYLESII.
" 403. ODONTOGLOSSUM ALEXANDRÆ OUTRAMII.
" 404. CATTLEYA MAXIMA MARCHETTIANA.

LONDON:

PUBLISHED BY B. S. WILLIAMS & SON,

AT THE

VICTORIA AND PARADISE NURSERIES, UPPER HOLLOWAY, N.

[All Rights Reserved.]

CASES FOR BINDING the Volumes of this Work can be supplied, PRICE 3s. 6d. EACH.
ALL BACK PARTS KEPT IN STOCK.

WILLIAMS' SHADING MATERIALS FOR ORCHIDS.

THE MOST SUITABLE FOR
SHADING ORCHIDS, FERNS,

PALMS

AND

Stove & Greenhouse Plants

It is a strong, durable Cotton Netting, woven in squares so close as to exclude the direct rays of the sun, but admitting the greatest amount of light attainable through shading.

It withstands the weather better than any other class of shading, and may be beneficially used on account of the thickness of its texture, during cold weather, to keep the frost out.

The leading Orchid and Plant Growers in the country have used this material for some years, and speak very highly of it, pronouncing it to be the very best material for plants they have ever used.

Blinds made up and fixed complete.

Sold in pieces, 30 yards long by 1½ yards wide. Price 40s. each. Samples submitted gratis.

WILLIAMS' NEW "EUREKA" SHADING.

REGISTERED.



A WANT HAS LONG BEEN FELT AMONG CULTIVATORS for a good, cheap shading which can be readily applied where blinds are not used. This new material is introduced to supply this want. It is in the form of a white powder, and is prepared for use by applying boiling water to the compound, and allowing it to cool, when it can be applied by means of a brush.

This new shading is a great advantage over "Summer Cloud," and other preparations, which have to be applied in a warm state—a most inconvenient method. In addition to this, it is of a white colour, which, being a non-conductor of heat reflects the rays of the sun, thereby keeping the houses upon which it is used much cooler. It dries instantaneously, and can be rubbed off easily, when moist, without the use of soda, which is required where paint is used. It will last the whole season, and it is not necessary to wash it off, as it will disappear by degrees when the autumn rains come; this is a great point in its favour, as well as being

The Cheapest Shading in the Market.

This Shading may be used not only upon Greenhouses, but upon Skylights, Windows, or anywhere where glass is employed.

This Shading can be supplied in a Green Powder if desired.

Sold in 1 lb. packets, with directions for use, price 1s. each. 1 lb. free by Parcel Post for 1s. 4½d.; 2 lbs. ditto for 2s. 6d.

Each Packet will make Half-a-gallon of shading material when mixed.

WILLIAMS' ORCHID-GROWERS' SUNDRIES.

BEST SELECTED FIBROUS PEAT FOR ORCHIDS.

10s. 6d. per sack, 21s. and 42s. per crate.

FRESH SPHAGNUM MOSS FOR ORCHIDS.

3s. per bushel, 12s. per sack.

OCTAGONAL TEAK-WOOD ORCHID BASKETS.

These Baskets, which are in increasing demand among Orchid Growers, are well made with the best quality Octagonal Teak Rods, fastened with Copper Wire. They are ordinarily made square, but can be had in Cylindrical, Boat, or Raft shapes. They are elegant in appearance, strong, and durable.

Outside Measure of Basket.	With Copper Wire, Nails, and Suspenders. Per doz.—s. d.	Outside Measure of Basket.	With Copper Wire, Nails, and Suspenders. Per doz.—s. d.	Per inch run
3 inches	6 0	8 inches	16 0	Rafts ... 1d.
4 "	8 0	9 "	18 0	Boats ... 1½d.
5 "	10 0	10 "	21 0	Cylinders ... 2d.
6 "	12 0	11 "	23 0	
7 "	14 0	12 "	26 0	

Special Shapes and Sizes made to order.

WILLIAMS' ORCHID PANS.

These Pans are well adapted and highly recommended for growing Orchids in, suspended from the roof, and are a good substitute for wooden baskets and blocks. The Pans, as sold, have holes bored in the side for attaching the wires to.

Diameter.	Per doz.—s. d.	Diameter.	Per doz.—s. d.	Diameter.	Per doz.—s. d.
2 inches...	1 0	3½ inches...	1 9	6 inches ...	4 0
2½ "	1 3	4 "	2 3	7 "	5 0
3 "	1 6	5 "	3 0	8 "	6 0

B. S. WILLIAMS & SON,
VICTORIA AND PARADISE NURSERIES,
UPPER HOLLOWAY, LONDON, N.

B. S. WILLIAMS & SON'S NOVELTIES IN SEEDS, &C., FOR 1890.

Sold only in Sealed Packets bearing our Trade Mark.

NEW ORNAMENTAL-LEAVED BEET.

(McGregor's Favourite.)

Awarded First Class Certificate by the Royal Horticultural Society, September 25th, 1888. This attractive and beautiful variety of Beet is quite a distinct and new departure, and will prove a great acquisition in the Flower Garden. It is very effective when used in ribbon borders, &c. It may also be grown as a pot plant, and used for table decoration. The leaves are of a rich bronzy crimson colour, narrow, arching, about 6 to 8 inches long, and fold inwards, resembling in habit a narrow-leaved *Dracæna*.

Per packet, 1s.

PRIMULA SINENSIS FIMBRIATA, "EMPRESS."

This is a very fine semi-double variety, similar in habit and constitution to *Firefly*. The colour is a delicate pink of a pleasing tone. It is very suitable for conservatory decoration.

Per packet, 3s. 6d.

PRIMULA SINENSIS FIMBRIATA, "FIREFLY."

This is a beautiful semi-double variety, of very robust and vigorous constitution. The habit of the plant is very fine and symmetrical, and it is exceedingly free flowering. The colour is of a deep crimson, somewhat more intense in shade than *Meteor*. It comes very true from seed, and will be found most serviceable for conservatory decoration.

Per packet, 3s. 6d.

GLOXINIA "GOUVILLE" STRAIN.

We have much pleasure in being able to offer, through the kindness of the Comte de Germiny, seeds of this splendid strain, which has the reputation of being the finest on the Continent. It invariably takes First Prizes wherever exhibited. The flowers are of immense size and substance, of very brilliant and varied colour, beautifully tигged and spotted, and contain a fair proportion of self colours.

Per packet, 2s. 6d.

EARLEYS' HARDY CURLED SPROUT.

This new variety was raised by Mr. William Earley, the well-known horticulturist of Ilford, from whom we have purchased the entire stock, who describes it as follows:—"A cross between the *Brussels Sprouts* and *Kale, Scotch Curled*. The latter was crossed with Brussels Sprout pollen. This has produced a robust variety with true Brussels Sprout habit, the foliage being midway between the two parents; the sprouts also partake of the curled habit of the seed-bearing parent. It is extremely hardy, carrying its robust, green foliage until late spring, and is destined to fill up the gap (often a large one) between late Brussels Sprouts and early Summer Cabbage. Being devoid of the roughness of Scotch Kale when cooked, and entirely free from the strong taste of Brussels Sprouts, its flavour is peculiarly original and pleasing. The thick-stalked dense crowns add very materially to its merits." Seeds now offered were grown direct from the plants produced by the cross-fertilised pod.

Per packet, 2s. 6d.

THE NEW GLADIOLI, "SNOW-WHITE."

The raiser describes it as follows:—"It is the best white Gladiolus ever grown. The flowers are well formed, and have a paper whiteness we have never seen in any other sort. The flowers are of exceptional substance, lasting a remarkable length of time when cut. Every bloom on the spike can be used individually for cut-flower work. The spikes are of good size, set solidly and perfect, with the florets from bottom to top. The petals are gracefully recurved, and, in many cases, beautifully crisped. Under ordinary circumstances nearly the entire flower is a perfect paper-white, with a slight cream shade on lower half of the lower petal. A faint line of purple extends about half-way through the lower petal. For withstanding dews, rains, and hot sunshine without changing colour, we have never seen its equal. It is not good one week and stained with pink and purple the next, like all the other light-coloured Gladioli we have ever seen. It comes just the same each year, and week after week."

Per doz., 21s.; each, 2s.

Illustrated Seed Catalogue for 1890, now ready, gratis and post free.

VICTORIA & PARADISE NURSERIES, UPPER HOLLOWAY, LONDON, N.

MR. J. C. STEVENS'

SALES BY AUCTION

OF

ESTABLISHED AND IMPORTED ORCHIDS

TAKE PLACE

EVERY WEEK AT HIS GREAT ROOMS,

38, KING STREET, COVENT GARDEN.

CATALOGUES FORWARDED ON RECEIPT OF TWO STAMPS.

SPECIAL NOTICE.—The price of the "Gardeners' Chronicle" is Threepence.

THE GARDENERS' CHRONICLE

("THE TIMES OF HORTICULTURE").

A Weekly Illustrated Journal

(ESTABLISHED 1841)

DEVOTED TO ALL BRANCHES OF GARDENING, FORESTRY, & RURAL PURSUITS.

EVERY FRIDAY, Price Threepence; Post Free to the Continent, Fourpence.

ALL SUBSCRIPTIONS PAYABLE IN ADVANCE.

THE UNITED KINGDOM: Twelve Months, 15s.; Six Months, 7s. 6d.; Three Months, 3s. 9d.; post free.

FOREIGN SUBSCRIPTIONS (excepting India and China): Including Postage, 17s. 6d. for Twelve Months. India and China, 19s. 6d.

P.O.O. to be made payable at The Post Office, 42, DRURY LANE, London, to W. RICHARDS.

W. RICHARDS, 41, WELLINGTON STREET, STRAND, LONDON.

MESSRS. PROTHEROE & MORRIS'S AUCTION SALES

ESTABLISHED & IMPORTED ORCHIDS

Take place Every Week at their

CENTRAL SALE ROOMS,

67 & 68, CHEAPSIDE, LONDON, E.C.

(Next door but one to Bennett's Clock).

CATALOGUES WILL BE FORWARDED ON APPLICATION.

CONTRACTORS TO HER MAJESTY'S WAR DEPARTMENT.

THE THAMES BANK IRON COMPANY,

(Telegraphic Address—"HOTWATER, LONDON." Telephone—No. 4,763.)

HAVE NOW PLEASURE IN BRINGING TO THE NOTICE OF HORTICULTURISTS AND GARDENERS GENERALLY THEIR

"CHAMPION" Horizontal Tubular Boiler (PATENT No. 9090.)

WHICH IS WITHOUT DOUBT THE BEST ALL-ROUND BOILER IN THE MARKET.

It combines all the advantages of its class so well known, and by the improved method of forming the joints, viz., with India Rubber Washers, the old and too often ineffectual way of caulking the joints is entirely dispensed with.

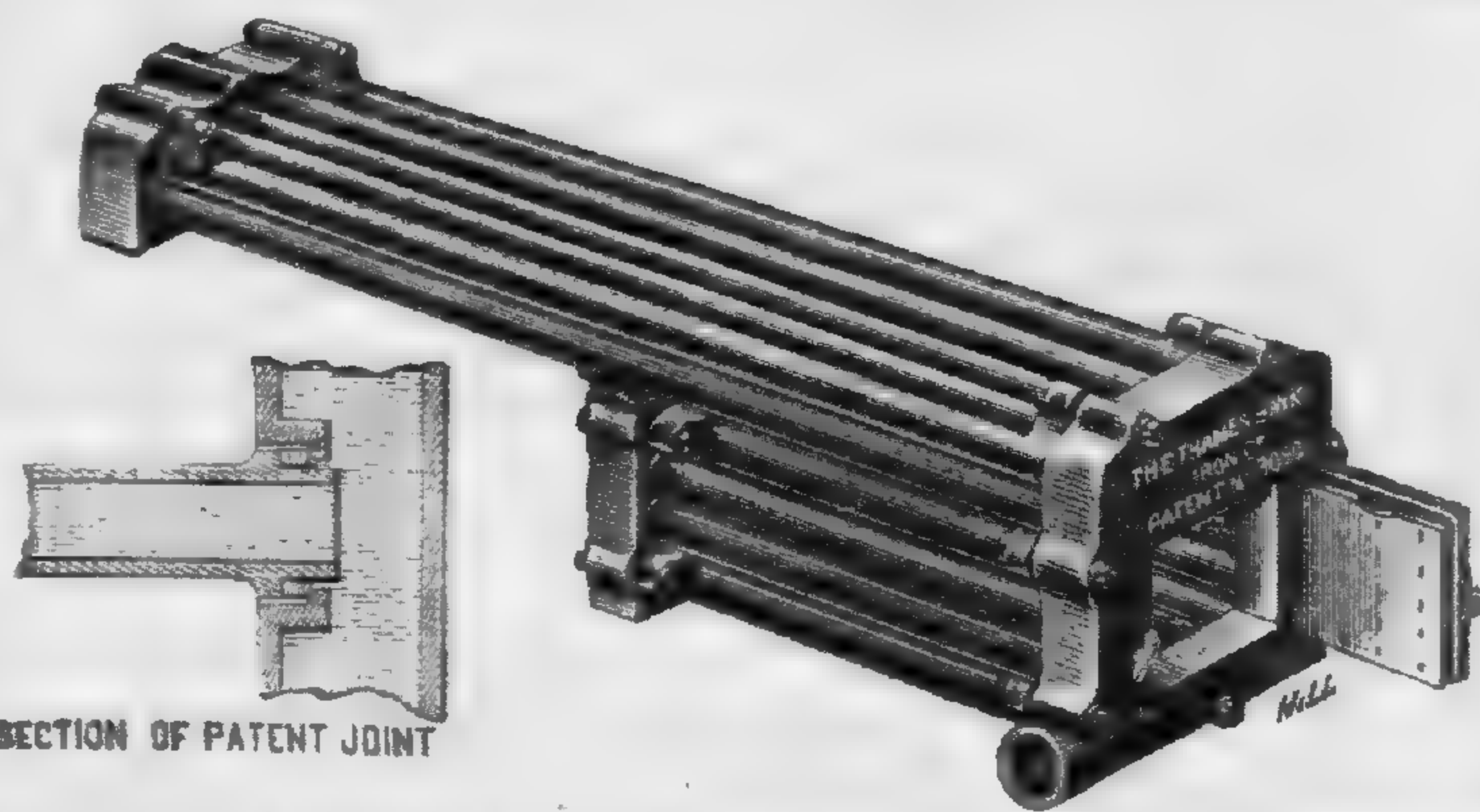

SECTION OF PATENT JOINT

It can be erected in a few hours, and may be relied upon as a thoroughly sound and good Hot-water Generator. It has been carefully tested in every possible way, more especially with regard to power and durability, and the result has been highly satisfactory.

In the event of a Pipe requiring to be replaced, we have perfected an arrangement whereby same may be effected in the course of a FEW MINUTES, without the necessity of disturbing the brickwork setting.

THE LARGEST AND MOST COMPLETE STOCK OF

HOT-WATER BOILERS OF EVERY DESCRIPTION,

PIPES, CONNECTIONS, VALVES, VENTILATING GEAR, &c.

INSPECTION INVITED.

PRICE LIST ON APPLICATION.

ILLUSTRATED CATALOGUE, 1s.

UPPER GROUND STREET, BLACKFRIARS, LONDON, S.E.

VOL. IX.—PART 102.

PRICE, 5s.

THE
ORCHID ALBUM,

COMPRISING

COLOURED FIGURES AND DESCRIPTIONS
OF
NEW, RARE, AND BEAUTIFUL
ORCHIDACEOUS PLANTS.

CONDUCTED BY

ROBERT WARNER, F.L.S., F.R.H.S.,

AUTHOR OF SELECT ORCHIDACEOUS PLANTS,

HENRY WILLIAMS, F.R.H.S.,

AND

WILLIAM HUGH GOWER.

THE COLOURED FIGURES BY JOHN NUGENT FITCH, F.L.S.

CONTENTS.

- PLATE 405. ONCIDIUM LARKINIANUM.
" 406. ODONTOGLOSSUM YOUNGII.
" 407. DENDROBIUM ALBUM.
" 408. LYCASTE GIGANTEA.

LONDON:

PUBLISHED BY B. S. WILLIAMS & SON,

AT THE

VICTORIA AND PARADISE NURSERIES, UPPER HOLLOWAY, N.

[All Rights Reserved.]

WILLIAMS' SHADING MATERIALS FOR ORCHIDS,

THE MOST SUITABLE FOR
SHADING ORCHIDS, FERNS,
PALMS

AND
Stove & Greenhouse Plants

It is a strong, durable Cotton Netting, woven in squares so close as to exclude the direct rays of the sun, but admitting the greatest amount of light attainable through shading.

It withstands the weather better than any other class of shading, and may be beneficially used on account of the thickness of its texture, during cold weather, to keep the frost out. The leading Orchid and Plant Growers in the country have used this material for some years, and speak very highly of it, pronouncing it to be the very best material for plants they have ever used.

Blinds made up and fixed complete.

Sold in pieces, 30 yards long by 1½ yards wide. Price 40s. each. Samples submitted gratis.

WILLIAMS' NEW "EUREKA" SHADING.

REGISTERED.



A WANT HAS LONG BEEN FELT AMONG CULTIVATORS for a good, cheap shading which can be readily applied where blinds are not used. This new material is introduced to supply this want. It is in the form of a white powder, and is prepared for use by applying boiling water to the compound, and allowing it to cool, when it can be applied by means of a brush. This new shading

is a great advantage over "Summer Cloud," and other preparations, which have to be applied in a warm state—a most inconvenient method. In addition to this, it is of a white colour, which, being a non-conductor of heat reflects the rays of the sun, thereby keeping the houses upon which it is used much cooler. It dries instantaneously, and can be rubbed off easily, when moist, without the use of soda, which is required where paint is used. It will last the whole season, and it is not necessary to wash it off, as it will disappear by degrees when the autumn rains come; this is a great point in its favour, as well as being

The Cheapest Shading in the Market.

This Shading may be used not only upon Greenhouses, but upon Skylights, Windows, or anywhere where glass is employed.

This Shading can be supplied in a Green Powder if desired.

Sold in 1 lb. packets, with directions for use, price 1s. each. 1 lb. free by Parcel Post for 1s. 4½d.; 2 lbs. ditto for 2s. 6d.

Each Packet will make Half-a-gallon of shading material when mixed.

WILLIAMS' ORCHID-GROWERS' SUNDRIES.

BEST SELECTED FIBROUS PEAT FOR ORCHIDS.

10s. 6d. per sack, 21s. and 42s. per crate.

FRESH SPHAGNUM MOSS FOR ORCHIDS.

3s. per bushel, 12s. per sack.

OCTAGONAL TEAK-WOOD ORCHID BASKETS.

These Baskets, which are in increasing demand among Orchid Growers, are well made with the best quality Octagonal Teak Rods, fastened with Copper Wire. They are ordinarily made square, but can be had in Cylindrical, Boat, or Raft shapes. They are elegant in appearance, strong, and durable.

Outside Measure of Basket.	With Copper Wire, Nails, and Suspenders. Per doz.—s. d.	Outside Measure of Basket.	With Copper Wire, Nails, and Suspenders. Per doz.—s. d.	Per inch run
3 inches	6 0	8 inches	16 0	Rafts ... 1d.
4 "	8 0	9 "	18 0	Boats ... 1½d.
5 "	10 0	10 "	21 0	Cylinders ... 2d.
6 "	12 0	11 "	23 0	
7 "	14 0	12 "	26 0	

Special Shapes and Sizes made to order.

WILLIAMS' ORCHID PANS.

These Pans are well adapted and highly recommended for growing Orchids in, suspended from the roof, and are a good substitute for wooden baskets and blocks. The Pans, as sold, have holes bored in the side for attaching the wires to.

Diameter.	Per doz.—s. d.	Diameter.	Per doz.—s. d.	Diameter.	Per doz.—s. d.
2 inches	1 0	3½ inches	1 9	6 inches	4 0
2½ "	1 3	4 "	2 3	7 "	5 0
3 "	1 6	5 "	3 0	8 "	6 0

B. S. WILLIAMS & SON,
VICTORIA AND PARADISE NURSERIES,
UPPER HOLLOWAY, LONDON, N.

WHITE ROMAN HYACINTHS,

& C.

B. S. WILLIAMS & SON

Have received a magnificent importation of Well-ripened
and Heavy Bulbs of

WHITE ROMAN HYACINTHS.

(EARLY WHITE)

From 5 to 6 $\frac{1}{4}$ inches in
circumference.

PAPER-WHITE NARCISSUS.

From 5 to 6 inches in
circumference.

DOUBLE ROMAN NARCISSUS

From 5 to 6 $\frac{1}{4}$ inches in
circumference.

LILIUM CANDIDUM.

Pure white, extra strong.

EARLY ORDERS SOLICITED.

Illustrated Bulb Catalogue post free on application.

➤ Victoria and Paradise Nurseries, ➤

UPPER HOLLOWAY, LONDON, N.

MR. J. C. STEVENS'

SALES BY AUCTION

OF

ESTABLISHED AND IMPORTED ORCHIDS

TAKE PLACE

EVERY WEEK AT HIS GREAT ROOMS,

38, KING STREET, COVENT GARDEN.

CATALOGUES FORWARDED ON RECEIPT OF TWO STAMPS.

SPECIAL NOTICE.—The price of the "Gardeners' Chronicle" is Threepence.

THE GARDENERS' CHRONICLE

("THE TIMES OF HORTICULTURE").

A Weekly Illustrated Journal

(ESTABLISHED 1841)

DEVOTED TO ALL BRANCHES OF GARDENING, FORESTRY, & RURAL PURSUITS.

EVERY FRIDAY, Price Threepence; Post Free to the Continent, Fourpence.

ALL SUBSCRIPTIONS PAYABLE IN ADVANCE.

THE UNITED KINGDOM: Twelve Months, 15s.; Six Months, 7s. 6d.; Three Months, 3s. 9d.; post free.

FOREIGN SUBSCRIPTIONS (excepting India and China): Including Postage, 17s. 6d. for Twelve Months. India and China, 19s. 6d.

P.O.O. to be made payable at The Post Office, 42, DRURY LANE, London, to W. RICHARDS.

W. RICHARDS, 41, WELLINGTON STREET, STRAND, LONDON.

MESSRS. PROTHEROE & MORRIS'S

AUCTION SALES

ESTABLISHED & IMPORTED ORCHIDS

Take place Every Week at their

CENTRAL SALE ROOMS,

67 & 68, CHEAPSIDE, LONDON, E.C.

(Next door but one to Bennett's Clock).

CATALOGUES WILL BE FORWARDED ON APPLICATION.

CONTRACTORS TO HER MAJESTY'S WAR DEPARTMENT.

THE THAMES BANK IRON COMPANY,

(Telegraphic Address—"HOTWATER, LONDON." Telephone—No. 4,763.)

HAVE NOW PLEASURE IN BRINGING TO THE NOTICE OF HORTICULTURISTS AND GARDENERS GENERALLY THEIR

"CHAMPION" Horizontal Tubular Boiler (PATENT No. 9090.)

WHICH IS WITHOUT DOUBT THE BEST ALL-ROUND BOILER IN THE MARKET.

It combines all the advantages of its class so well known, and by the improved method of forming the joints, viz., with India Rubber Washers, the old and too often ineffectual way of caulking the joints is entirely dispensed with.

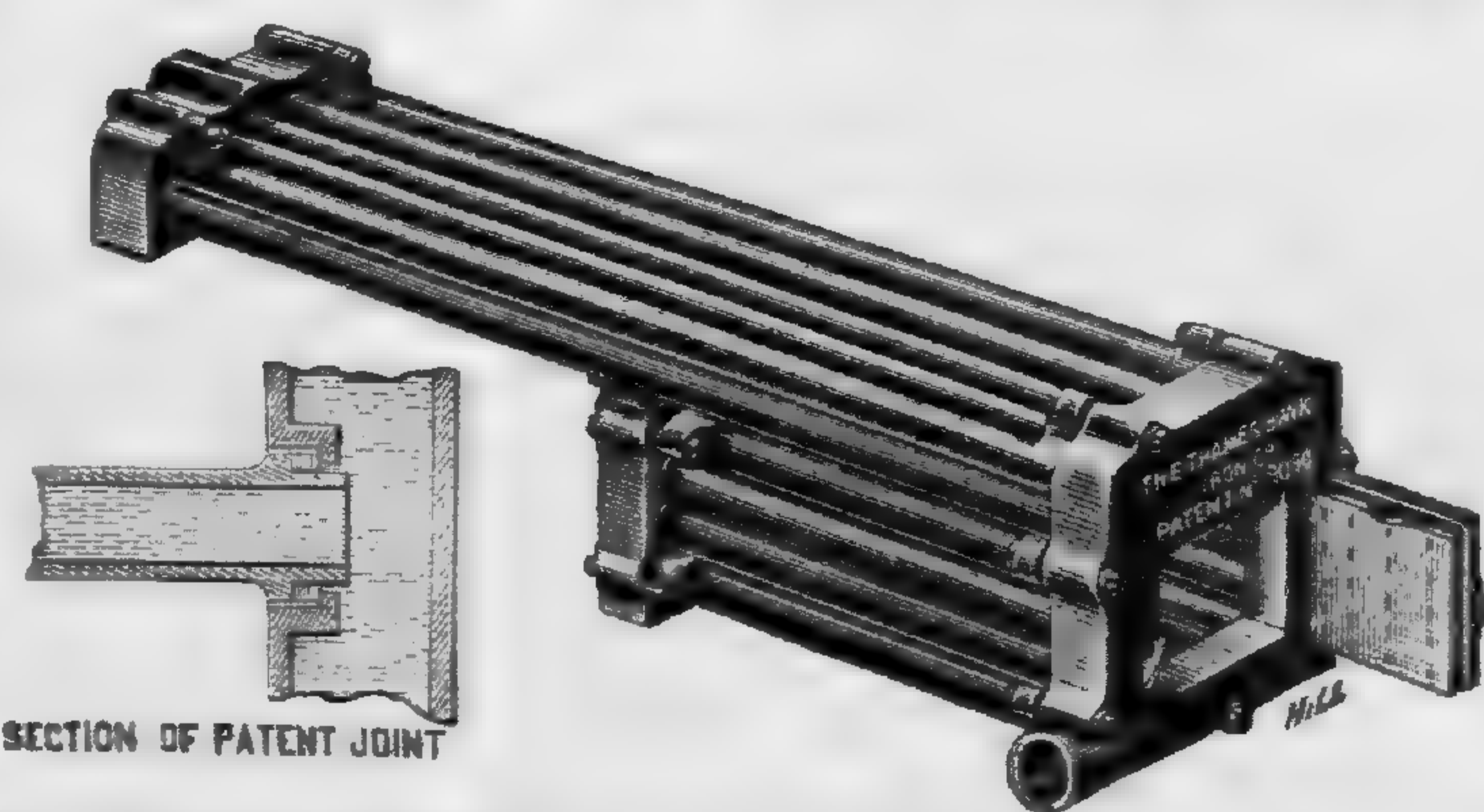

SECTION OF PATENT JOINT

It can be erected in a few hours, and may be relied upon as a thoroughly sound and good Hot-water Generator. It has been carefully tested in every possible way, more especially with regard to power and durability, and the result has been highly satisfactory.

In the event of a Pipe requiring to be replaced, we have perfected an arrangement whereby same may be effected in the course of a FEW MINUTES, without the necessity of disturbing the brickwork setting.

THE LARGEST AND MOST COMPLETE STOCK OF

HOT-WATER BOILERS OF EVERY DESCRIPTION,

PIPES, CONNECTIONS, VALVES, VENTILATING GEAR, &c.

INSPECTION INVITED.

PRICE LIST ON APPLICATION.

ILLUSTRATED CATALOGUE, IS.

UPPER GROUND STREET, BLACKFRIARS, LONDON, S.E.

VOL. IX.—PART 103.

PRICE, 5s.

THE
ORCHID ALBUM,

COMPRISING

COLOURED FIGURES AND DESCRIPTIONS
OF
NEW, RARE, AND BEAUTIFUL
ORCHIDACEOUS PLANTS.

CONDUCTED BY

ROBERT WARNER, F.L.S., F.R.H.S.,
AUTHOR OF SELECT ORCHIDACEOUS PLANTS,

HENRY WILLIAMS, F.R.H.S.,

AND

WILLIAM HUGH GOWER.

THE COLOURED FIGURES BY JOHN NUGENT FITCH, F.L.S.

CONTENTS.

- PLATE 409. VANDA TERES CANDIDA.
„ 410. ZYGOPETALUM CRINITUM CÆRULEUM.
„ 411. DENDROBIUM SCHNEIDERIANUM.
„ 412. MILTONIA BLEUANA SPLENDENS.

LONDON:

PUBLISHED BY B. S. WILLIAMS & SON,

AT THE

VICTORIA AND PARADISE NURSERIES, UPPER HOLLOWAY, N.

[All Rights Reserved.]

WORKS BY B. S. WILLIAMS, F.L.S., F.R.H.S.

"Mr. WILLIAMS has long been known as one of our best and most successful plant growers."—*Gardeners' Chronicle*.
 "Mr. WILLIAMS' skill as a plant cultivator is well and widely known."—*Journal of Horticulture*.

THE ORCHID-GROWERS' MANUAL

6th EDITION, ENLARGED AND REVISED.

BY

BENJAMIN SAMUEL WILLIAMS, F.L.S., F.R.H.S.,

Author of "The Orchid Album," "Select Ferns and Lycopods," "Choice Stove and Greenhouse Flowering Plants," "Choice Stove and Greenhouse Ornamental-leaved Plants," &c.

Post 8vo., Cloth, price 15s.; Free by Parcel Post, 15s. 6d.

PROFUSELY ILLUSTRATED WITH A LARGE NUMBER OF PAGE AND DOUBLE-PAGE ENGRAVINGS ON WOOD, TOGETHER WITH BLOCKS ILLUSTRATIVE OF TYPES OF THE VARIOUS GENERA.

The first edition of this work was published thirty-six years ago, and ever since its publication it has been considered to be the Orchid-Growers' Text Book, as is evinced by the numerous letters we are constantly receiving from all parts of the world, wherein our correspondents state that the "Orchid-Growers' Manual has been their only book of reference and constant friend in the cultivation of these plants.

This popular work has been entirely remodelled and revised up to the present time, and has been enlarged to 659 pages. It contains descriptions of upwards of 1470 species and varieties of Orchidaceous plants, together with 478 synonyms; also authorities for the names, the families to which the various genera belong, the flowering period, native country, and references to figures. In addition to this, chapters on the following subjects are given:—

Habitats of Tropical Orchids
 Season for Collecting Orchids
 Hints on Collecting Orchids
 Risks of Collecting Orchids
 Orchid Treatment during Growth
 Orchid Treatment during Rest
 Adaptation of Treatment to Surrounding Conditions
 Treatment of Newly-Imported Plants
 Treatment of Plants in Bloom

On Making Orchid Baskets
 Potting Epiphytal Orchids
 Potting Terrestrial Orchids
 Mode of Inducing back Growth
 Watering Orchids
 Propagation of Orchids
 Raising Orchids from Seeds
 Orchids for Room Decoration
 Construction of Orchid Houses
 Glazing of Orchid Houses

Heating of Orchid Houses
 Ventilation of Orchid Houses
 Shading of Orchid Houses
 Growing Specimen Orchids for Exhibition
 Treatment Preparatory to Exhibition
 Packing Orchids for Exhibitions
 Insects and other Enemies
 Diseases of Orchids
 Greenhouse and Frame Orchids.

Making in all the most complete work on Orchids ever published.

PUBLISHED BY B. S. WILLIAMS & SON,
 VICTORIA AND PARADISE NURSERIES, UPPER HOLLOWAY, LONDON, N.

WILLIAMS' ORCHID-GROWERS' SUNDRIES.

BEST SELECTED FIBROUS PEAT FOR ORCHIDS.

10s. 6d. per sack, 21s. and 42s. per crate.

FRESH SPHAGNUM MOSS FOR ORCHIDS.

3s. per bushel, 12s. per sack.

OCTAGONAL TEAK-WOOD ORCHID BASKETS.

These Baskets, which are in increasing demand among Orchid Growers, are well made with the best quality *Octagonal Teak Rods*, fastened with Copper Wire. They are ordinarily made square, but can be had in Cylindrical, Boat, or Raft shapes. They are elegant in appearance, strong, and durable.

Outside Measure of Basket.	With Copper Wire, Nails, and Suspenders. Per doz.—s. d.	Outside Measure of Basket.	With Copper Wire, Nails, and Suspenders. Per doz.—s. d.	Rafts	Per inch run ... 1d.
3 inches	6 0	8 inches	16 0	Boats	1½d.
4 "	8 0	9 "	18 0	Cylinders	2d.
5 "	10 0	10 "	21 0		
6 "	12 0	11 "	23 0		
7 "	14 0	12 "	26 0		

Special Shapes and Sizes made to order.

WILLIAMS' ORCHID PANS.

These Pans are well adapted and highly recommended for growing Orchids in, suspended from the roof, and are a good substitute for wooden baskets and blocks. The Pans, as sold, have holes bored in the side for attaching the wires to.

Diameter.	Per doz.—s. d.	Diameter.	Per doz.—s. d.	Diameter.	Per doz.—s. d.
2 inches... ..	1 0	3½ inches... ..	1 9	6 inches	4 0
2½ "	1 3	4 "	2 3	7 "	5 0
3 "	1 6	5 "	3 0	8 "	6 0

B. S. WILLIAMS & SON,
 VICTORIA AND PARADISE NURSERIES,
 UPPER HOLLOWAY, LONDON, N.

WHITE ROMAN HYACINTHS,

&C.

B. S. WILLIAMS & SON

Have received a magnificent importation of Well-ripened
and Heavy Bulbs of

WHITE ROMAN HYACINTHS.

(EARLY WHITE)

From 5 to 6 $\frac{1}{4}$ inches in
circumference.

PAPER-WHITE NARCISSUS.

From 5 to 6 inches in
circumference.

DOUBLE ROMAN NARCISSUS

From 5 to 6 $\frac{1}{4}$ inches in
circumference.

LILIUM CANDIDUM.

Pure white, extra strong.

EARLY ORDERS SOLICITED.

Illustrated Bulb Catalogue post free on application.

↔ Victoria and Paradise Nurseries, ↔

UPPER HOLLOWAY, LONDON, N.

MR. J. C. STEVENS'

SALES BY AUCTION

ESTABLISHED AND IMPORTED ORCHIDS

TAKE PLACE

EVERY WEEK AT HIS GREAT ROOMS,

38, KING STREET, COVENT GARDEN.

CATALOGUES FORWARDED ON RECEIPT OF TWO STAMPS.

SPECIAL NOTICE.—The price of the "Gardeners' Chronicle" is Threepence.

THE GARDENERS' CHRONICLE

("THE TIMES OF HORTICULTURE").

A Weekly Illustrated Journal

(ESTABLISHED 1841)

DEVOTED TO ALL BRANCHES OF GARDENING, FORESTRY, & RURAL PURSUITS.

EVERY FRIDAY, Price Threepence; Post Free to the Continent, Fourpence.

ALL SUBSCRIPTIONS PAYABLE IN ADVANCE.

THE UNITED KINGDOM: Twelve Months, 15s.; Six Months, 7s. 6d.; Three Months, 3s. 9d.; post free.

FOREIGN SUBSCRIPTIONS (excepting India and China): Including Postage, 17s. 6d. for Twelve Months. India and China, 19s. 6d.

P.O.O. to be made payable at The Post Office, 42, DRURY LANE, London, to W. RICHARDS.

W. RICHARDS, 41, WELLINGTON STREET, STRAND, LONDON.

MESSRS. PROTHEROE & MORRIS'S

AUCTION SALES

ESTABLISHED & IMPORTED ORCHIDS

Take place Every Week at their

CENTRAL SALE ROOMS,

67 & 68, CHEAPSIDE, LONDON, E.C.

(Next door but one to Bennett's Clock).

CATALOGUES WILL BE FORWARDED ON APPLICATION.

CONTRACTORS TO HER MAJESTY'S WAR DEPARTMENT.

THE THAMES BANK IRON COMPANY,

(Telegraphic Address—"HOTWATER, LONDON." Telephone—No. 4,763.)

HAVE NOW PLEASURE IN BRINGING TO THE NOTICE OF HORTICULTURISTS AND GARDENERS GENERALLY THEIR

"CHAMPION" Horizontal Tubular Boiler (PATENT No. 9090.)

WHICH IS WITHOUT DOUBT THE BEST ALL-ROUND BOILER IN THE MARKET.

It combines all the advantages of its class so well known, and by the improved method of forming the joints, viz., with India Rubber Washers, the old and too often ineffectual way of caulking the joints is entirely dispensed with.

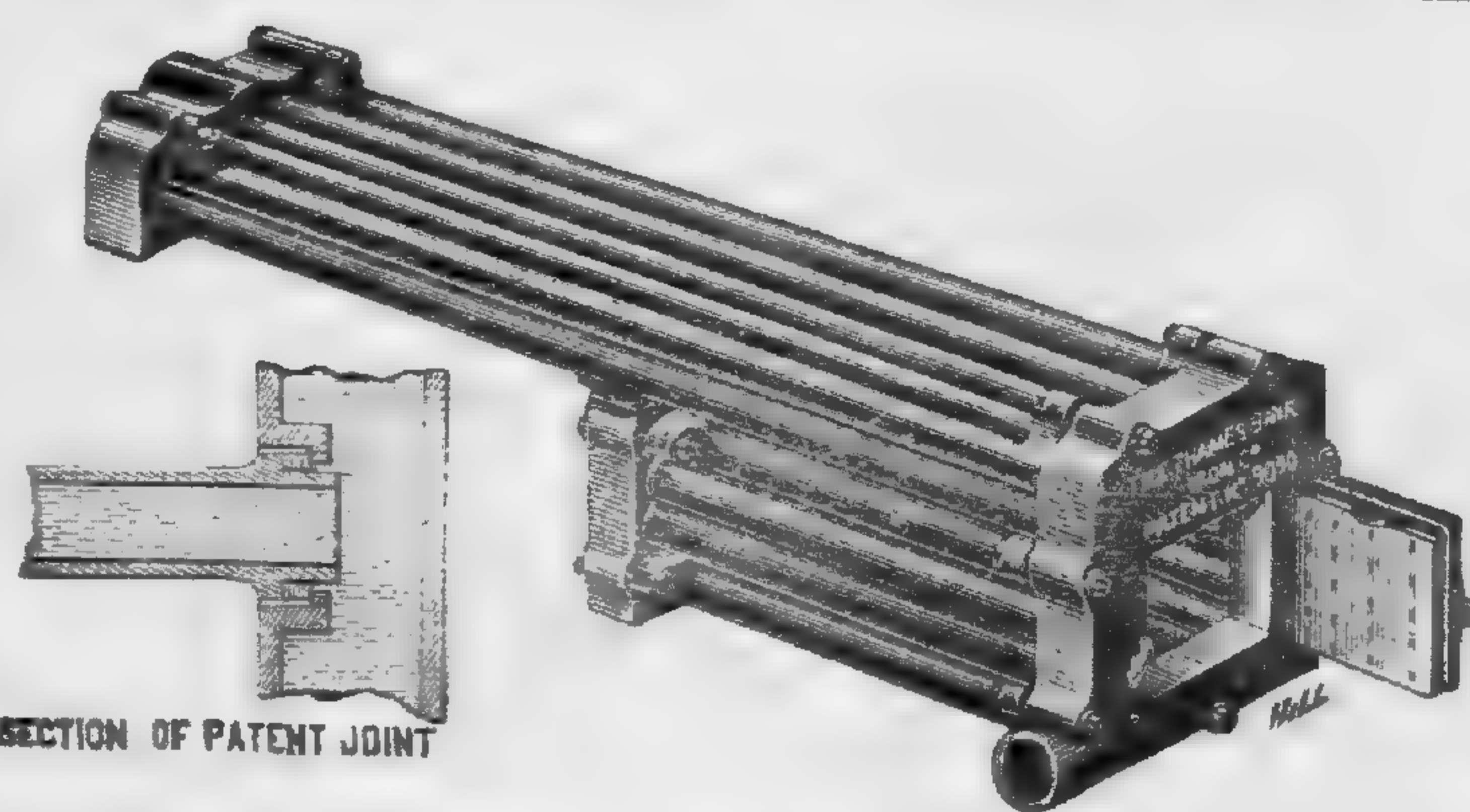

SECTION OF PATENT JOINT

It can be erected in a few hours, and may be relied upon as a thoroughly sound and good Hot-water Generator. It has been carefully tested in every possible way, more especially with regard to power and durability, and the result has been highly satisfactory.

In the event of a Pipe requiring to be replaced, we have perfected an arrangement whereby same may be effected in the course of a FEW MINUTES, without the necessity of disturbing the brickwork setting.

THE LARGEST AND MOST COMPLETE STOCK OF

HOT-WATER BOILERS OF EVERY DESCRIPTION,

PIPES, CONNECTIONS, VALVES, VENTILATING GEAR, &c.

INSPECTION INVITED.

PRICE LIST ON APPLICATION.

ILLUSTRATED CATALOGUE, 1s.

UPPER GROUND STREET, BLACKFRIARS, LONDON, S.E.

VOL. IX.—PART 104.

PRICE, 5s.

THE
ORCHID ALBUM,

COMPRISING

COLOURED FIGURES AND DESCRIPTIONS
OF
NEW, RARE, AND BEAUTIFUL
ORCHIDACEOUS PLANTS.

CONDUCTED BY

ROBERT WARNER, F.L.S., F.R.H.S.,
AUTHOR OF SELECT ORCHIDACEOUS PLANTS,

HENRY WILLIAMS, F.R.H.S.,

AND

WILLIAM HUGH GOWER.

THE COLOURED FIGURES BY JOHN NUGENT FITCH, F.L.S.

CONTENTS.

- PLATE 413. LÆLIA ELEGANS BROOMEANA.
" 414. ODONTOGLOSSUM CRISPUM PLUMATUM.
" 415. PHALÆNOPSIS BRYMERIANA.
" 416. BRASSAVOLA GLAUCA.

LONDON:

PUBLISHED BY B. S. WILLIAMS & SON,

AT THE

VICTORIA AND PARADISE NURSERIES, UPPER HOLLOWAY, N.

[All Rights Reserved.]

WORKS BY B. S. WILLIAMS, F.L.S., F.R.H.S.

"Mr. WILLIAMS has long been known as one of our best and most successful plant growers."—*Gardeners' Chronicle*.

"Mr. WILLIAMS' skill as a plant cultivator is well and widely known."—*Journal of Horticulture*.

THE ORCHID-GROWERS' MANUAL

6th EDITION, ENLARGED AND REVISED.

BY

BENJAMIN SAMUEL WILLIAMS, F.L.S., F.R.H.S.,

Author of "The Orchid Album," "Select Ferns and Lycopods," "Choice Stove and Greenhouse Flowering Plants," "Choice Stove and Greenhouse Ornamental-leaved Plants," &c.

Post 8vo., Cloth, price 15s.; Free by Parcel Post, 15s. 6d.

PROFUSELY ILLUSTRATED WITH A LARGE NUMBER OF PAGE AND DOUBLE-PAGE ENGRAVINGS ON WOOD, TOGETHER WITH BLOCKS ILLUSTRATIVE OF TYPES OF THE VARIOUS GENERA.

The first edition of this work was published thirty-six years ago, and ever since its publication it has been considered to be the Orchid-Growers' Text Book, as is evinced by the numerous letters we are constantly receiving from all parts of the world, wherein our correspondents state that the "Orchid-Growers' Manual has been their only book of reference and constant friend in the cultivation of these plants.

This popular work has been entirely remodelled and revised up to the present time, and has been enlarged to 659 pages. It contains descriptions of upwards of 1470 species and varieties of Orchidaceous plants, together with 478 synonyms; also authorities for the names, the families to which the various genera belong, the flowering period, native country, and references to figures. In addition to this, chapters on the following subjects are given:—

Habitats of Tropical Orchids	On Making Orchid Baskets	Heating of Orchid Houses
Season for Collecting Orchids	Potting Epiphytal Orchids	Ventilation of Orchid Houses
Hints on Collecting Orchids	Potting Terrestrial Orchids	Shading of Orchid Houses
Risks of Collecting Orchids	Mode of Inducing back Growth	Growing Specimen Orchids for Exhibition
Orchid Treatment during Growth	Watering Orchids	Treatment Preparatory to Exhibition
Orchid Treatment during Rest	Propagation of Orchids	Packing Orchids for Exhibitions
Adaptation of Treatment to Surrounding Conditions	Raising Orchids from Seeds	Insects and other Enemies
Treatment of Newly-Imported Plants	Orchids for Room Decoration	Diseases of Orchids
Treatment of Plants in Bloom	Construction of Orchid Houses	Greenhouse and Frame Orchids.
	Glazing of Orchid Houses	

Making in all the most complete work on Orchids ever published.

PUBLISHED BY B. S. WILLIAMS & SON,
VICTORIA AND PARADISE NURSERIES, UPPER HOLLOWAY, LONDON, N.

WILLIAMS' ORCHID-GROWERS' SUNDRIES.

BEST SELECTED FIBROUS PEAT FOR ORCHIDS.

10s. 6d. per sack, 21s. and 42s. per crate.

FRESH SPHAGNUM MOSS FOR ORCHIDS.

3s. per bushel, 12s. per sack.

OCTAGONAL TEAK-WOOD ORCHID BASKETS.

These Baskets, which are in increasing demand among Orchid Growers, are well made with the best quality Octagonal Teak Rods, fastened with Copper Wire. They are ordinarily made square, but can be had in Cylindrical, Boat, or Raft shapes. They are elegant in appearance, strong, and durable.

Outside Measure of Basket.	With Copper Wire, Nails, and Suspenders. Per doz.—s. d.	Outside Measure of Basket.	With Copper Wire, Nails, and Suspenders. Per doz.—s. d.	Rafts	Per inch run
3 inches	6 0	8 inches	16 0	Boats	1½d.
4 "	8 0	9 "	18 0	Cylinders	2d.
5 "	10 0	10 "	21 0		
6 "	12 0	11 "	23 0		
7 "	14 0	12 "	26 0		

Special Shapes and Sizes made to order.

WILLIAMS' ORCHID PANS.

These Pans are well adapted and highly recommended for growing Orchids in, suspended from the roof, and are a good substitute for wooden baskets and blocks. The Pans, as sold, have holes bored in the side for attaching the wires to.

Diameter.	Per doz.—s. d.	Diameter.	Per doz.—s. d.	Diameter.	Per doz.—s. d.
2 inches...	1 0	3½ inches...	1 9	6 inches	4 0
2½ "	1 3	4 "	2 3	7 "	5 0
3 "	1 6	5 "	3 0	8 "	6 0

B. S. WILLIAMS & SON,
VICTORIA AND PARADISE NURSERIES,
UPPER HOLLOWAY, LONDON, N.

B. S. WILLIAMS & SON'S SELECTION OF PLANTS,

SUITABLE FOR

Autumn and Winter Flowering and Early Forcing,

NOW READY FOR DELIVERY.

	Per doz.—s.	d.	s.	d.		Per doz.—s.	d.	s.	d.			
Acacia armata	18	0	&	24	0	Hydrangea paniculata grandiflora	12	0	&	24	0	
Andromeda floribunda	18	0	"	30	0	— — — standards	30	0	"	42	0	
Azalea indica, of sorts	24s.	30	0	"	42	0	Jasminum grandiflorum	30	0	"	42	0
— mollis, seedlings... ..	15s., 18s.	30	0	"	42	0	Kalmia latifolia	30	0	"	42	0
Begonias, winter flowering	18	0	"	24	0	Laurustinus, nice compact heads	18	0	"	24	0	
Bouvardias, of sorts	18	0	"	24	0	Lilac alba virginalis	42	0	
Camellias, of sorts	30	0	"	42	0	— Charles X.	30	0	"	42	0	
Carnations, Tree, of sorts	18	0	"	30	0	— persica	30	0	"	42	0	
Citrus sinensis, with fruits... ..	42	0	"	60	0	Philadelphus coronarius, Mock Orange	30	0	
Cyclamen, of sorts	18s.	24	0	"	30	0	Primula sinensis alba plena	18	0	"	24	0
Daphne indica rubra	30	0	"	42	0	— — double, of sorts	30	0	"	42	0	
Deutzia gracilis, in pots	18	0	"	24	0	Prunus sinensis alba plena	18	0	"	30	0	
— crenata fl. pl., in pots	18	0	"	30	0	Rhododendrons, hardy, choice selection	24	0	"	42	0	
— Pride of Rochester, from the ground	18	0	"	24	0	Roses, finest Teas and Hybrid Perpetuals, strong plants	30	0	"	42	0	
Epacris, of sorts	24	0	"	30	0	Solanum hybridum Empress, and others	24	0	"	30	0	
Epiphyllums, of sorts	30	0	"	42	0	Staphylea colchica... ..	24	0	"	30	0	
Ericas, of sorts... ..	18s.	24	0	"	30	0	Viburnum opulus (Guelder Rose)	24	0	"	30	0
Gardenias, of sorts	24	0	"	30	0							

CHOICE SELECTION OF BULBS AND ROOTS.

	Per doz.—s.	d.	s.	d.		
Achimenes, choice selection... ..	12s.	18	0	to 30	0	
Amaryllis, choice selection, named kinds	42	0	"	105	0	
— choice selection, seedlings	30	0	"	42	0	
Begonias, Tuberos-rooted, choice named, 24s.	30	0	"	42	0	
— — unnamed	9s., 12s.	18	0	"	24	0
Dahlias, Single and Double, pot roots... ..	6s.	9	0	"	12	0
Dielytra spectabilis, extra strong clumps	5	0	&	9	0	
Eucharis amazonica	24s.	30	0	"	42	0
Gloriosa superba each, 3s. 6d. & 5s.						
— Plantii each, 2s. 6d.						
Gloxinias, choice named selection	18s.	24	0	"	30	0
— Seedlings, good bulbs	9s.	12	0	"	18	0
Griffinia hyacinthina each, 5s.						
Helleborus niger (Christmas Rose)	15s.	18	0	"	30	0
Hyacinthus candicans, per 100, 10s. 6d. & 15s.	1	6	"	2	6	
Lily of the Valley, imported clumps	12	0	"	15	0	
— — — single crowns ... per 100, 6s.						
Spiræa astilboides, strong clumps, each, 2/6 & 3/6.						
— japonica, strong clumps	5	0	"	9	0	
— — aurea reticulata each, 1s.				9	0	
— palmata	9	0	"	12	0	
Vallota purpurea (Scarborough Lily)	18	0	"	30	0	
Urceolina pendula	42	0	

GLADIOLUS.

	Per doz.—s.	d.	s.	d.	
Brenchleyensis per 100, 5s. & 7s. 6d.	1	0	&	1	3
Colvillii (The Bride), the best for cutting	1	6
English-grown Seedlings, per 100, 17s. 6d. & 21s.	2	6	"	3	0

LILIUMS.

	Per doz.—s.	d.	s.	d.	
Auratum 6s., 9s., 12s., 15s., 24s.	30	0	&	42	0
Candidum, home grown ... per 100, 20s. to 25s.	3	0
— imported ,, 15s. to 20s.	2	6	"	3	0
Chalcedonicum	9	0	"	12	0
Croceum per 100, 21s.	3	0
Excelsum	15	0
Harrisii 9s., 12s., 15s., 18s., 24s.	30	0	"	42	0
Lancifolium album...	12	0
— roseum	7	6
— rubrum	7	6
Longiflorum per 100, 35s.	4	6
Martagon purpureum, purple	3	0
— rubrum, scarlet	12	0
Tigrinum per 100, 10s. 6d.	1	6

TUBEROSES.

	Per doz.—s.	d.
American, imported, ready in December ... per 100, 25s.	4	0
Pearl, extra fine	4	0
— Excelsior, very fine	5	0

VICTORIA AND PARADISE NURSERIES, UPPER HOLLOWAY, LONDON, N.

MR. J. C. STEVENS'

SALES BY AUCTION

OF

ESTABLISHED AND IMPORTED ORCHIDS

TAKE PLACE

EVERY WEEK AT HIS GREAT ROOMS,

38, KING STREET, COVENT GARDEN.

CATALOGUES FORWARDED ON RECEIPT OF TWO STAMPS.

SPECIAL NOTICE.—The price of the "Gardeners' Chronicle" is Threepence.

THE GARDENERS' CHRONICLE

("THE TIMES OF HORTICULTURE").

A Weekly Illustrated Journal

(ESTABLISHED 1841)

DEVOTED TO ALL BRANCHES OF GARDENING, FORESTRY, & RURAL PURSUITS.

EVERY FRIDAY, Price Threepence; Post Free to the Continent, Fourpence.

ALL SUBSCRIPTIONS PAYABLE IN ADVANCE.

THE UNITED KINGDOM: Twelve Months, 15s.; Six Months, 7s. 6d.; Three Months, 3s. 9d.; post free.

FOREIGN SUBSCRIPTIONS (excepting India and China): Including Postage, 17s. 6d. for Twelve Months. India and China, 19s. 6d.

P.O.O. to be made payable at The Post Office, 42, DRURY LANE, London, to W. RICHARDS.

W. RICHARDS, 41, WELLINGTON STREET, STRAND, LONDON.

MESSRS. PROTHEROE & MORRIS'S

AUCTION SALES

ESTABLISHED & IMPORTED ORCHIDS

Take place Every Week at their

CENTRAL SALE ROOMS,

67 & 68, CHEAPSIDE, LONDON, E.C.

(Next door but one to Bennett's Clock).

CATALOGUES WILL BE FORWARDED ON APPLICATION.

CONTRACTORS TO HER MAJESTY'S WAR DEPARTMENT.

THE THAMES BANK IRON COMPANY,

(Telegraphic Address—"HOTWATER, LONDON." Telephone—No. 4,763.)

HAVE NOW PLEASURE IN BRINGING TO THE NOTICE OF HORTICULTURISTS AND GARDENERS GENERALLY THEIR

"CHAMPION" Horizontal Tubular Boiler (PATENT No. 9090.)

WHICH IS WITHOUT DOUBT THE BEST ALL-ROUND BOILER IN THE MARKET.

It combines all the advantages of its class so well known, and by the improved method of forming the joints, viz., with India Rubber Washers, the old and too often ineffectual way of caulking the joints is entirely dispensed with.

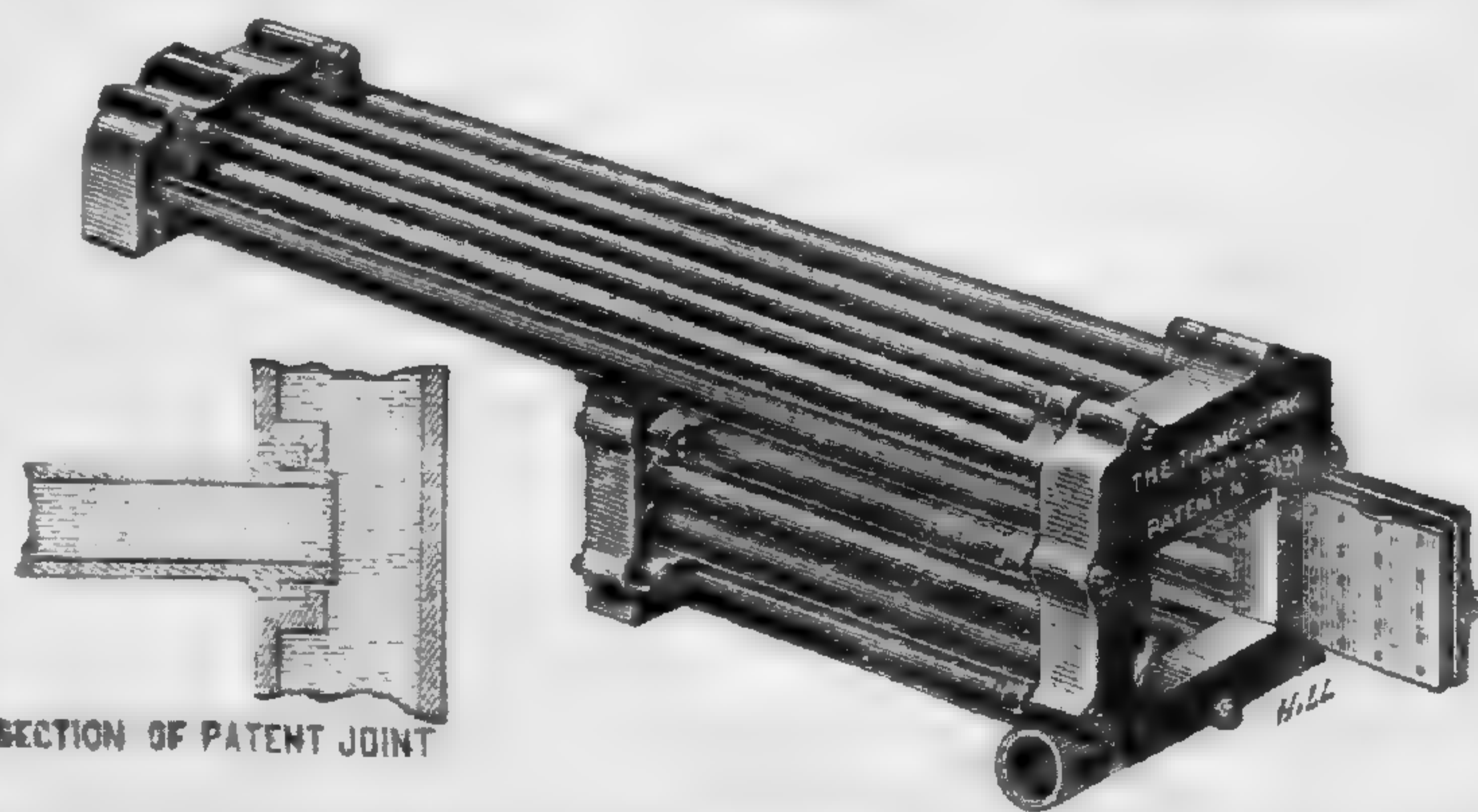

It can be erected in a few hours, and may be relied upon as a thoroughly sound and good Hot-water Generator. It has been carefully tested in every possible way, more especially with regard to power and durability, and the result has been highly satisfactory.

In the event of a Pipe requiring to be replaced, we have perfected an arrangement whereby same may be effected in the course of a FEW MINUTES, without the necessity of disturbing the brickwork setting.

THE LARGEST AND MOST COMPLETE STOCK OF

HOT-WATER BOILERS OF EVERY DESCRIPTION,

PIPES, CONNECTIONS, VALVES, VENTILATING GEAR, &c.

INSPECTION INVITED.

PRICE LIST ON APPLICATION.

ILLUSTRATED CATALOGUE, 1s.

UPPER GROUND STREET, BLACKFRIARS, LONDON, S.E.

VOL. IX.—PART 105.

PRICE, 5s.

THE
ORCHID ALBUM,
COMPRISING
COLOURED FIGURES AND DESCRIPTIONS
OF
NEW, RARE, AND BEAUTIFUL
ORCHIDACEOUS PLANTS.

CONDUCTED BY
ROBERT WARNER, F.L.S., F.R.H.S.,
AUTHOR OF SELECT ORCHIDACEOUS PLANTS,
HENRY WILLIAMS, F.R.H.S.,
AND
WILLIAM HUGH GOWER.

THE COLOURED FIGURES BY JOHN NUGENT FITCH, F.L.S.

Mo. Bot. Garden.

CONTENTS.

- PLATE 417. ODONTOGLOSSUM URO-SKINNERI.
„ 418. CYPRIPIEDIUM MARSHALLIANUM.
„ 419. DENDROBIUM CHRYSOTIS.
„ 420. CYPRIPIEDIUM CENANTHUM SUPERBUM.

LONDON:
PUBLISHED BY B. S. WILLIAMS & SON,
AT THE
VICTORIA AND PARADISE NURSERIES, UPPER HOLLOWAY, N.

[All Rights Reserved.]

CASES FOR BINDING the Volumes of this Work can be supplied, PRICE 3s. 6d. EACH.
ALL BACK PARTS KEPT IN STOCK.

WORKS BY B. S. WILLIAMS, F.L.S., F.R.H.S.

"Mr. WILLIAMS has long been known as one of our best and most successful plant growers."—*Gardeners' Chronicle*.
 "Mr. WILLIAMS' skill as a plant cultivator is well and widely known."—*Journal of Horticulture*.

THE ORCHID-GROWERS' MANUAL

6th EDITION, ENLARGED AND REVISED.

BY

BENJAMIN SAMUEL WILLIAMS, F.L.S., F.R.H.S.,

Author of "The Orchid Album," "Select Ferns and Lycopods," "Choice Stove and Greenhouse Flowering Plants," "Choice Stove and Greenhouse Ornamental-leaved Plants," &c.

Post 8vo., Cloth, price 15s.; Free by Parcel Post, 15s. 6d.

PROFUSELY ILLUSTRATED WITH A LARGE NUMBER OF PAGE AND DOUBLE-PAGE ENGRAVINGS ON WOOD, TOGETHER WITH BLOCKS ILLUSTRATIVE OF TYPES OF THE VARIOUS GENERA.

The first edition of this work was published thirty-six years ago, and ever since its publication it has been considered to be the Orchid-Growers' Text Book, as is evinced by the numerous letters we are constantly receiving from all parts of the world, wherein our correspondents state that the "Orchid-Growers' Manual has been their only book of reference and constant friend in the cultivation of these plants.

This popular work has been entirely remodelled and revised up to the present time, and has been enlarged to 659 pages. It contains descriptions of upwards of 1470 species and varieties of Orchidaceous plants, together with 478 synonyms; also authorities for the names, the families to which the various genera belong, the flowering period, native country, and references to figures. In addition to this, chapters on the following subjects are given:—

Habitats of Tropical Orchids
 Season for Collecting Orchids
 Hints on Collecting Orchids
 Risks of Collecting Orchids
 Orchid Treatment during Growth
 Orchid Treatment during Rest
 Adaptation of Treatment to Surrounding Conditions
 Treatment of Newly-Imported Plants
 Treatment of Plants in Bloom

On Making Orchid Baskets
 Potting Epiphytal Orchids
 Potting Terrestrial Orchids
 Mode of Inducing back Growth
 Watering Orchids
 Propagation of Orchids
 Raising Orchids from Seeds
 Orchids for Room Decoration
 Construction of Orchid Houses
 Glazing of Orchid Houses

Heating of Orchid Houses
 Ventilation of Orchid Houses
 Shading of Orchid Houses
 Growing Specimen Orchids for Exhibition
 Treatment Preparatory to Exhibition
 Packing Orchids for Exhibitions
 Insects and other Enemies
 Diseases of Orchids
 Greenhouse and Frame Orchids.

Making in all the most complete work on Orchids ever published.

PUBLISHED BY B. S. WILLIAMS & SON,
 VICTORIA AND PARADISE NURSERIES, UPPER HOLLOWAY, LONDON, N.

WILLIAMS' ORCHID-GROWERS' SUNDRIES.

BEST SELECTED FIBROUS PEAT FOR ORCHIDS.

10s. 6d. per sack, 21s. and 42s. per crate.

FRESH SPHAGNUM MOSS FOR ORCHIDS.

3s. per bushel, 12s. per sack.

OCTAGONAL TEAK-WOOD ORCHID BASKETS.

These Baskets, which are in increasing demand among Orchid Growers, are well made with the best quality *Octagonal* Teak Rods, fastened with Copper Wire. They are ordinarily made square, but can be had in Cylindrical, Boat, or Raft shapes. They are elegant in appearance, strong, and durable.

Outside Measure of Basket.	With Copper Wire, Nails, and Suspenders. Per doz.—s. d.	Outside Measure of Basket.	With Copper Wire, Nails, and Suspenders. Per doz.—s. d.	Per inch run
3 inches	6 0	8 inches	16 0	Rafts 1d.
4 "	8 0	9 "	18 0	Boats 1½d.
5 "	10 0	10 "	21 0	Cylinders 2d.
6 "	12 0	11 "	23 0	
7 "	14 0	12 "	26 0	

Special Shapes and Sizes made to order.

WILLIAMS' ORCHID PANS.

These Pans are well adapted and highly recommended for growing Orchids in, suspended from the roof, and are a good substitute for wooden baskets and blocks. The Pans, as sold, have holes bored in the side for attaching the wires to.

Diameter.	Per doz.—s. d.	Diameter.	Per doz.—s. d.	Diameter.	Per doz.—s. d.
2 inches	1 0	3½ inches	1 9	6 inches	4 0
2½ "	1 3	4 "	2 3	7 "	5 0
3 "	1 6	5 "	3 0	8 "	6 0

B. S. WILLIAMS & SON,
 VICTORIA AND PARADISE NURSERIES,
 UPPER HOLLOWAY, LONDON, N.

B. S. WILLIAMS & SON'S

SELECTION OF PLANTS,

SUITABLE FOR
WINTER FLOWERING AND EARLY FORCING,
NOW READY FOR DELIVERY.

	Per doz.—s.	d.	s.	d.
Acacia armata	18	0	&	24 0
Andromeda floribunda	18	0	"	30 0
Azalea indica, of sorts	24s.	30	0	" 42 0
— mollis, seedlings... ..	15s., 18s.	30	0	" 42 0
Begonias, winter flowering	18	0	"	24 0
Bouvardias, of sorts	18	0	"	24 0
Camellias, of sorts	30	0	"	42 0
Carnations, Tree, of sorts	18	0	"	30 0
Cyclamen, of sorts	18s.	24	0	" 30 0
Daphne indica rubra	30	0	"	42 0
Deutzia gracilis, in pots	18	0	"	24 0
— crenata fl. pl., in pots	18	0	"	30 0
— Pride of Rochester, from the ground	18	0	"	24 0
Epacris, of sorts	24	0	"	30 0
Epiphyllums, of sorts	30	0	"	42 0
Ericas, of sorts... ..	18s.	24	0	" 30 0
Gardenias, of sorts	24	0	"	30 0

	Per doz.—s.	d.	s.	d.
Hydrangea paniculata grandiflora	12	0	&	24 0
— — standards	30	0	"	42 0
Jasminum grandiflorum	30	0	"	42 0
Kalmia latifolia	30	0	"	42 0
Laurustinus, nice compact heads	18	0	"	24 0
Lilac alba virginalis				42 0
— Charles X.	30	0	"	42 0
— persica	30	0	"	42 0
Philadelphus coronarius, Mock Orange				30 0
Primula sinensis alba plena	18	0	"	24 0
— — double, of sorts	30	0	"	42 0
Prunus sinensis alba plena	18	0	"	30 0
Rhododendrons, hardy, choice selection	24	0	"	42 0
Roses, finest Teas and Hybrid Perpetuals, strong plants	30	0	"	42 0
Solanum hybridum Empress, and others	24	0	"	30 0
Viburnum opulus (Guelder Rose)	24	0	"	30 0

CHOICE SELECTION OF BULBS AND ROOTS.

	Per doz.—s.	d.	s.	d.
Achimenes, choice selection... ..	12s.	18	0	to 30 0
Amaryllis, choice selection, named kinds	42	0	"	105 0
— choice selection, seedlings	30	0	"	42 0
Begonias, Tuberous-rooted, choice named, 24s.	30	0	"	42 0
— — unnamed	9s., 12s.	18	0	" 24 0
Dahlias, Single and Double, pot roots... ..	6s.	9	0	" 12 0
Dielytra spectabilis, extra strong clumps	5	0	&	9 0
Eucharis amazonica	24s.	30	0	" 42 0
Gloriosa superba each, 3s. 6d. & 5s.				
— Plantii each, 2s. 6d.				
Gloxinias, choice named selection	18s.	24	0	" 30 0
— Seedlings, good bulbs	9s.	12	0	" 18 0
Griffinia hyacinthina each, 5s.				
Helleborus niger (Christmas Rose)	15s.	18	0	" 30 0
Hyacinthus candicans, per 100, 10s. 6d. & 15s.	1	6	"	2 6
Lily of the Valley, imported clumps	12	0	"	15 0
— — — — single crowns ... per 100, 6s.				
Spiræa astilboides, strong clumps, each, 2/6 & 3/6.				
— japonica, strong clumps	5	0	"	9 0
— — aurea reticulata each, 1s.				9 0
— palmata	9	0	"	12 0
Vallota purpurea (Scarborough Lily)	18	0	"	30 0
Urceolina pendula				42 0

GLADIOLUS.

	Per doz.—s.	d.	s.	d.
Brenchleyensis per 100, 5s. & 7s. 6d.	1	0	&	1 3
Colvillii (The Bride), the best for cutting				1 6
English-grown Seedlings, per 100, 17s. 6d. & 21s.	2	6	"	3 0

LILIUMS.

	Per doz.—s.	d.	s.	d.
Auratum 6s., 9s., 12s., 15s., 24s.	30	0	&	42 0
Candidum, home grown ... per 100, 20s. to 25s.				3 0
— imported " 15s. to 20s.	2	6	"	3 0
Chalcedonicum	9	0	"	12 0
Croceum per 100, 21s.				3 0
Excelsum				15 0
Harrisii 9s., 12s., 15s., 18s., 24s.	30	0	"	42 0
Lancifolium album... ..				12 0
— roseum				7 6
— rubrum				7 6
Longiflorum per 100, 35s.				4 6
Martagon purpureum, purple				3 0
— rubrum, scarlet				12 0
Tigrinum per 100, 10s. 6d.				1 6

TUBEROSES.

	Per doz.—s.	d.
American, imported, ready in December ... per 100, 25s.	4	0
Pearl, extra fine	4	0
— Excelsior, very fine	5	0

VICTORIA AND PARADISE NURSERIES, UPPER HOLLOWAY, LONDON, N.

MR. J. C. STEVENS'

SALES BY AUCTION

OF

ESTABLISHED AND IMPORTED ORCHIDS

TAKE PLACE

EVERY WEEK AT HIS GREAT ROOMS,

38, KING STREET, COVENT GARDEN.

CATALOGUES FORWARDED ON RECEIPT OF TWO STAMPS

SPECIAL NOTICE.—The price of the "Gardeners' Chronicle" is Threepence.

THE GARDENERS' CHRONICLE

("THE TIMES OF HORTICULTURE").

A Weekly Illustrated Journal

(ESTABLISHED 1841)

DEVOTED TO ALL BRANCHES OF GARDENING, FORESTRY, & RURAL PURSUITS.

EVERY FRIDAY, Price Threepence; Post Free to the Continent, Fourpence.

ALL SUBSCRIPTIONS PAYABLE IN ADVANCE.

THE UNITED KINGDOM: Twelve Months, 15s.; Six Months, 7s. 6d.; Three Months, 3s. 9d.; post free.

FOREIGN SUBSCRIPTIONS (excepting India and China): Including Postage, 17s. 6d. for Twelve Months. India and China, 19s. 6d.

P.O.O. to be made payable at The Post Office, 42, DRURY LANE, London, to W. RICHARDS.

W. RICHARDS, 41, WELLINGTON STREET, STRAND, LONDON.

MESSRS. PROTHEROE & MORRIS'S AUCTION SALES

ESTABLISHED & IMPORTED ORCHIDS

Take place Every Week at their

CENTRAL SALE ROOMS,
67 & 68, CHEAPSIDE, LONDON, E.C.

(Next door but one to Bennett's Clock).

CATALOGUES WILL BE FORWARDED ON APPLICATION.

CONTRACTORS TO HER MAJESTY'S WAR DEPARTMENT.

THE THAMES BANK IRON COMPANY,

(Telegraphic Address—"HOTWATER, LONDON." Telephone—No. 4,763.)

"CHAMPION" Horizontal Tubular Boiler (PATENT No. 9090.)

WHICH IS WITHOUT DOUBT THE BEST ALL-ROUND BOILER IN THE MARKET.

It combines all the advantages of its class so well known, and by the improved method of forming the joints, viz., with India Rubber Washers, the old and too often ineffectual way of caulking the joints is entirely dispensed with.

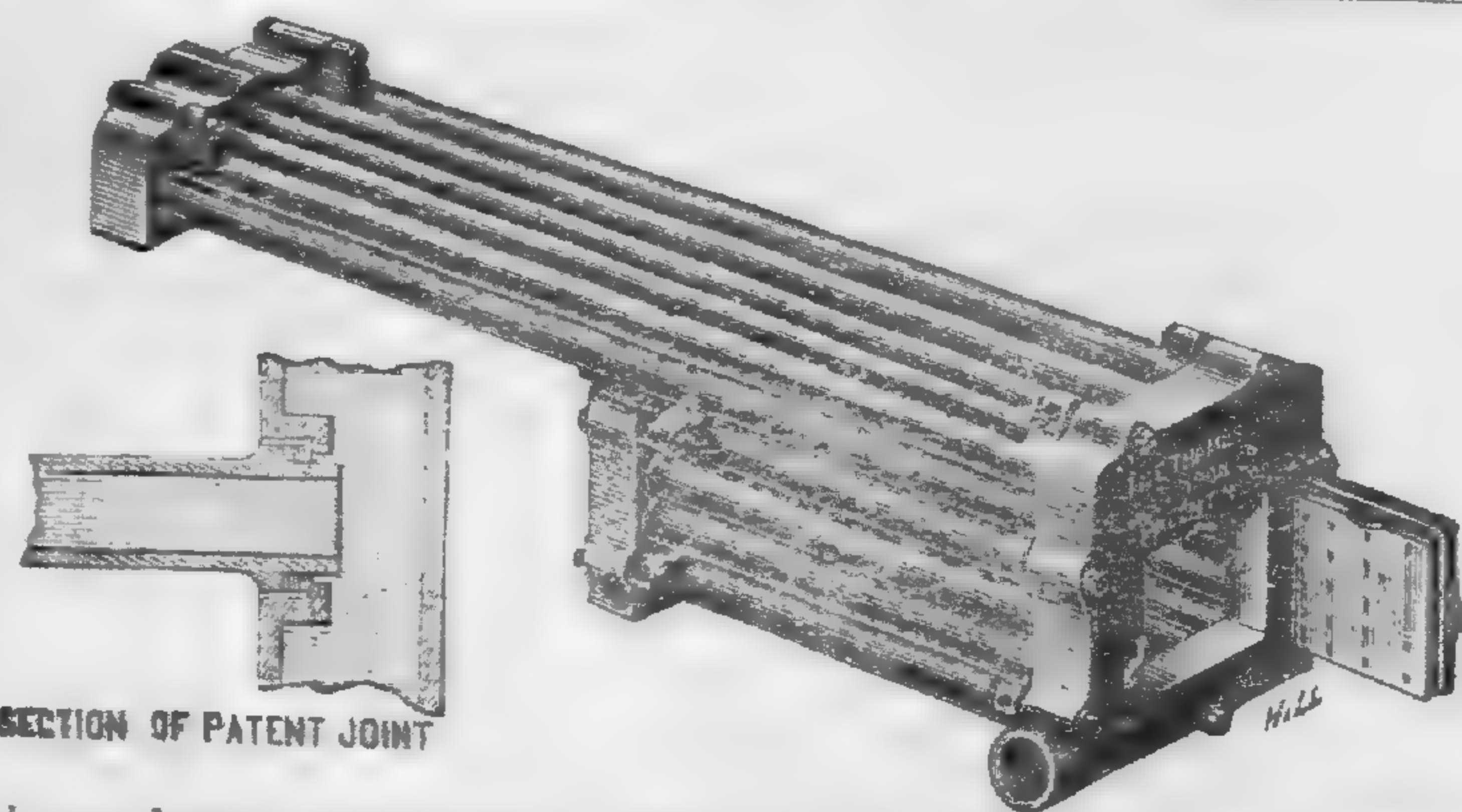

It can be erected in a few hours, and may be relied upon as a thoroughly sound and good Hot-water Generator. It has been carefully tested in every possible way, more especially with regard to power and durability, and the result has been highly satisfactory.

In the event of a Pipe requiring to be replaced, we have perfected an arrangement whereby same may be effected in the course of a FEW MINUTES, without the necessity of disturbing the brickwork setting.

THE LARGEST AND MOST COMPLETE STOCK OF
HOT-WATER BOILERS OF EVERY DESCRIPTION,
PIPES, CONNECTIONS, VALVES, VENTILATING GEAR, &c.

INSPECTION INVITED.

PRICE LIST ON APPLICATION.

ILLUSTRATED CATALOGUE, 1s.

UPPER GROUND STREET, BLACKFRIARS, LONDON, S.E.

VOL. IX.—PART 106.

PRICE, 5s.

THE
ORCHID ALBUM,

COMPRISING

COLOURED FIGURES AND DESCRIPTIONS
OF
NEW, RARE, AND BEAUTIFUL
ORCHIDACEOUS PLANTS.

CONDUCTED BY

ROBERT WARNER, F.L.S., F.R.H.S.,
AUTHOR OF SELECT ORCHIDACEOUS PLANTS,

HENRY WILLIAMS, F.L.S., F.R.H.S.,
AND

WILLIAM HUGH GOWER, F.R.H.S.

THE COLOURED FIGURES BY JOHN NUGENT FITCH, F.L.S.

CONTENTS.

- PLATE 421. CATTLEYA MOSSIÆ DECORA.
„ 422. DIPODIUM PALUDOSUM.
„ 423. ODONTOGLOSSUM GALEOTTIANUM.
„ 424. CATTLEYA CRISPA DELICATISSIMA.

LONDON:

PUBLISHED BY B. S. WILLIAMS & SON,

AT THE

VICTORIA AND PARADISE NURSERIES, UPPER HOLLOWAY, N.

[All Rights Reserved.]

CASES FOR BINDING the Volumes of this Work can be supplied, PRICE 3s. 6d. EACH.

ALL BACK PARTS KEPT IN STOCK.

WORKS BY B. S. WILLIAMS, F.L.S., F.R.H.S.

"Mr. WILLIAMS has long been known as one of our best and most successful plant growers."—*Gardeners' Chronicle*.
 "Mr. WILLIAMS' skill as a plant cultivator is well and widely known."—*Journal of Horticulture*.

THE ORCHID-GROWERS' MANUAL

6th EDITION, ENLARGED AND REVISED.

BY
 BENJAMIN SAMUEL WILLIAMS, F.L.S., F.R.H.S.,

Author of "The Orchid Album," "Select Ferns and Lycopods," "Choice Stove and Greenhouse Flowering Plants," "Choice Stove and Greenhouse Ornamental-leaved Plants," &c.

Post 8vo., Cloth, price 15s.; Free by Parcel Post, 15s. 6d.

PROFUSELY ILLUSTRATED WITH A LARGE NUMBER OF PAGE AND DOUBLE-PAGE ENGRAVINGS ON WOOD, TOGETHER WITH BLOCKS ILLUSTRATIVE OF TYPES OF THE VARIOUS GENERA.

The first edition of this work was published thirty-six years ago, and ever since its publication it has been considered to be the Orchid-Growers' Text Book, as is evinced by the numerous letters we are constantly receiving from all parts of the world, wherein our correspondents state that the "Orchid-Growers' Manual has been their only book of reference and constant friend in the cultivation of these plants.

This popular work has been entirely remodelled and revised up to the present time, and has been enlarged to 659 pages. It contains descriptions of upwards of 1470 species and varieties of Orchidaceous plants, together with 478 synonyms; also authorities for the names, the families to which the various genera belong, the flowering period, native country, and references to figures. In addition to this, chapters on the following subjects are given:—

Habitats of Tropical Orchids
 Season for Collecting Orchids
 Hints on Collecting Orchids
 Risks of Collecting Orchids
 Orchid Treatment during Growth
 Orchid Treatment during Rest
 Adaptation of Treatment to Surrounding Conditions
 Treatment of Newly-Imported Plants
 Treatment of Plants in Bloom

On Making Orchid Baskets
 Potting Epiphytal Orchids
 Potting Terrestrial Orchids
 Mode of Inducing back Growth
 Watering Orchids
 Propagation of Orchids
 Raising Orchids from Seeds
 Orchids for Room Decoration
 Construction of Orchid Houses
 Glazing of Orchid Houses

Heating of Orchid Houses
 Ventilation of Orchid Houses
 Shading of Orchid Houses
 Growing Specimen Orchids for Exhibition
 Treatment Preparatory to Exhibition
 Packing Orchids for Exhibitions
 Insects and other Enemies
 Diseases of Orchids
 Greenhouse and Frame Orchids.

Making in all the most complete work on Orchids ever published.

PUBLISHED BY B. S. WILLIAMS & SON,
 VICTORIA AND PARADISE NURSERIES, UPPER HOLLOWAY, LONDON, N.

WILLIAMS' ORCHID-GROWERS' SUNDRIES.

BEST SELECTED FIBROUS PEAT FOR ORCHIDS.

10s. 6d. per sack, 21s. and 42s. per crate.

FRESH SPHAGNUM MOSS FOR ORCHIDS.

3s. per bushel, 12s. per sack.

OCTAGONAL TEAK-WOOD ORCHID BASKETS.

These Baskets, which are in increasing demand among Orchid Growers, are well made with the best quality *Octagonal Teak Rods*, fastened with Copper Wire. They are ordinarily made square, but can be had in *Cylindrical, Boat, or Raft* shapes. They are elegant in appearance, strong, and durable.

Outside Measure of Basket.	With Copper Wire, Nails, and Suspenders. Per doz.—s. d.	Outside Measure of Basket.	With Copper Wire, Nails, and Suspenders. Per doz.—s. d.	Per inch run
3 inches	6 0	8 inches	16 0	Rafts 1d.
4 "	8 0	9 "	18 0	Boats 1½d.
5 "	10 0	10 "	21 0	Cylinders 2d.
6 "	12 0	11 "	23 0	
7 "	14 0	12 "	26 0	

Special Shapes and Sizes made to order.

WILLIAMS' ORCHID PANS.

These Pans are well adapted and highly recommended for growing Orchids in, suspended from the roof, and are a good substitute for wooden baskets and blocks. The Pans, as sold, have holes bored in the side for attaching the wires to.

Diameter.	Per doz.—s. d.	Diameter.	Per doz.—s. d.	Diameter.	Per doz.—s. d.
2 inches	1 0	3½ inches	1 9	6 inches	4 0
2½ "	1 3	4 "	2 3	7 "	5 0
3 "	1 6	5 "	3 0	8 "	6 0

B. S. WILLIAMS & SON,
 VICTORIA AND PARADISE NURSERIES,
 UPPER HOLLOWAY, LONDON, N.

B. S. WILLIAMS & SON'S

SELECTION OF PLANTS,

SUITABLE FOR
WINTER FLOWERING AND EARLY FORCING,
NOW READY FOR DELIVERY.

	Per doz.—	s.	d.	s.	d.		Per doz.—	s.	d.	s.	d.	
Acacia armata	18	0	&	24	0	Hydrangea paniculata grandiflora ...	12	0	&	24	0	
Andromeda floribunda	18	0	"	30	0	— — — standards	30	0	"	42	0	
Azalea indica, of sorts	24s.	30	0	"	42	0	Jasminum grandiflorum	30	0	"	42	0
— mollis, seedlings ..	15s., 18s.	30	0	"	42	0	Kalmia latifolia	30	0	"	42	0
Begonias, winter flowering	18	0	"	24	0	Laurustinus, nice compact heads ...	18	0	"	24	0	
Bouvardias, of sorts	18	0	"	24	0	Lilac alba virginalis	42	0	
Camellias, of sorts	30	0	"	42	0	— Charles X.	30	0	"	42	0	
Carnations, Tree, of sorts	18	0	"	30	0	— persica	30	0	"	42	0	
Cyclamen, of sorts	18s.	24	0	"	30	0	Philadelphus coronarius, Mock Orange	30	0
Daphne indica rubra	30	0	"	42	0	Primula sinensis alba plena	18	0	"	24	0	
Deutzia gracilis, in pots	18	0	"	24	0	— — double, of sorts	30	0	"	42	0	
— crenata fl. pl., in pots	18	0	"	30	0	Prunus sinensis alba plena	18	0	"	30	0	
— Pride of Rochester, from the ground	18	0	"	24	0	Rhododendrons, hardy, choice selection	24	0	"	42	0	
Epacris, of sorts	24	0	"	30	0	Roses, finest Teas and Hybrid Perpetuals,						
Epiphyllums, of sorts	30	0	"	42	0	strong plants	30	0	"	42	0	
Ericas, of sorts... ..	18s.	24	0	"	30	0	Solanum hybridum Empress, and others	24	0	"	30	0
Gardenias, of sorts	24	0	"	30	0	Viburnum opulus (Guelder Rose) ...	24	0	"	30	0	

CHOICE SELECTION OF BULBS AND ROOTS.

	Per doz.—	s.	d.	s.	d.	
Achimenes, choice selection... ..	12s.	18	0	to	30	0
Amaryllis, choice selection, named kinds	42	0	"	105	0	
— choice selection, seedlings	30	0	"	42	0	
Begonias, Tuberous-rooted, choice named, 24s.	30	0	"	42	0	
— — unnamed	9s., 12s.	18	0	"	24	0
Dahlias, Single and Double, pot roots... ..	6s.	9	0	"	12	0
Dielytra spectabilis, extra strong clumps	5	0	&	9	0	
Eucharis amazonica	24s.	30	0	"	42	0
Gloriosa superba	each, 3s. 6d. & 5s.					
— Plantii	each, 2s. 6d.					
Gloxinias, choice named selection	18s.	24	0	"	30	0
— Seedlings, good bulbs	9s.	12	0	"	18	0
Griffinia hyacinthina	each, 5s.					
Helleborus niger (Christmas Rose)	15s.	18	0	"	30	0
Hyacinthus candicans, per 100, 10s. 6d. & 15s.	1	6	"	2	6	
Lily of the Valley, imported clumps	12	0	"	15	0	
— — — — single crowns ... per 100, 6s.						
Spiræa astilboides, strong clumps, each, 2/6 & 3/6.						
— japonica, strong clumps	5	0	"	9	0	
— — aurea reticulata	each, 1s.				9	0
— palmata	9	0	"	12	0	
Vallota purpurea (Scarborough Lily)	18	0	"	30	0	
Urceolina pendula	42	0	

GLADIOLUS.

	Per doz.—	s.	d.	s.	d.	
Brenchleyensis	per 100, 5s. & 7s. 6d.	1	0	&	1	3
Colvillii (The Bride), the best for cutting	1	6	
English-grown Seedlings,						
per 100, 17s. 6d. & 21s.	2	6	"	3	0	

LILIUMS.

	Per doz.—	s.	d.	s.	d.	
Auratum	6s., 9s., 12s., 15s., 24s.	30	0	&	42	0
Candidum, home grown	per 100, 2's. to 25s.	3	0	
— imported	per 100, 15s. to 20s.	2	6	"	3	0
Chalcedonicum	9	0	"	12	0
Croceum	per 100, 21s.	3	0	
Excelsum	15	0	
Harrisii	9s., 12s., 15s., 18s., 24s.	30	0	"	42	0
Lancifolium album	12	0	
— roseum	7	6	
— rubrum	7	6	
Longiflorum	per 100, 35s.	4	6	
Martagon purpureum, purple	3	0	
— rubrum, scarlet	12	0	
Tigrinum	per 100, 10s. 6d.	1	6	

TUBEROSES.

	Per doz.—	s.	d.
American, imported, ready in December	per 100, 25s.	4	0
Pearl, extra fine	4	0
— Excelsior, very fine	5	0

VICTORIA AND PARADISE NURSERIES, UPPER HOLLOWAY, LONDON, N.

MR. J. C. STEVENS'

SALES BY AUCTION

OF

ESTABLISHED AND IMPORTED ORCHIDS

TAKE PLACE

EVERY WEEK AT HIS GREAT ROOMS,

38, KING STREET, COVENT GARDEN.

CATALOGUES FORWARDED ON RECEIPT OF TWO STAMPS

SPECIAL NOTICE.—The price of the "Gardeners' Chronicle" is Threepence.

THE GARDENERS' CHRONICLE

("THE TIMES OF HORTICULTURE").

A Weekly Illustrated Journal

(ESTABLISHED 1841)

DEVOTED TO ALL BRANCHES OF GARDENING, FORESTRY, & RURAL PURSUITS.

EVERY FRIDAY, Price Threepence; Post Free to the Continent, Fourpence.

ALL SUBSCRIPTIONS PAYABLE IN ADVANCE.

THE UNITED KINGDOM: Twelve Months, 15s.; Six Months, 7s. 6d.; Three Months, 3s. 9d.; post free.

FOREIGN SUBSCRIPTIONS (excepting India and China): Including Postage, 17s. 6d. for Twelve Months. India and China, 19s. 6d.

P.O.O. to be made payable at The Post Office, 42, DRURY LANE, London, to W. RICHARDS.

W. RICHARDS, 41, WELLINGTON STREET, STRAND, LONDON.

MESSRS. PROTHEROE & MORRIS'S

AUCTION SALES

ESTABLISHED & IMPORTED ORCHIDS

Take place Every Week at their

CENTRAL SALE ROOMS,

67 & 68, CHEAPSIDE, LONDON, E.C.

(Next door but one to Bennett's Clock).

CATALOGUES WILL BE FORWARDED ON APPLICATION.

CONTRACTORS TO HER MAJESTY'S WAR DEPARTMENT.

THE THAMES BANK IRON COMPANY,

(Telegraphic Address—"HOTWATER, LONDON." Telephone—No. 4,763.)

"CHAMPION" Horizontal Tubular Boiler (Patent)

THE BEST ALL-ROUND BOILER IN THE MARKET.

It combines all the advantages of its class so well known, and by the improved method of forming the joints, viz., with India Rubber Washers, the old and too often ineffectual way of caulking the joints is entirely dispensed with.

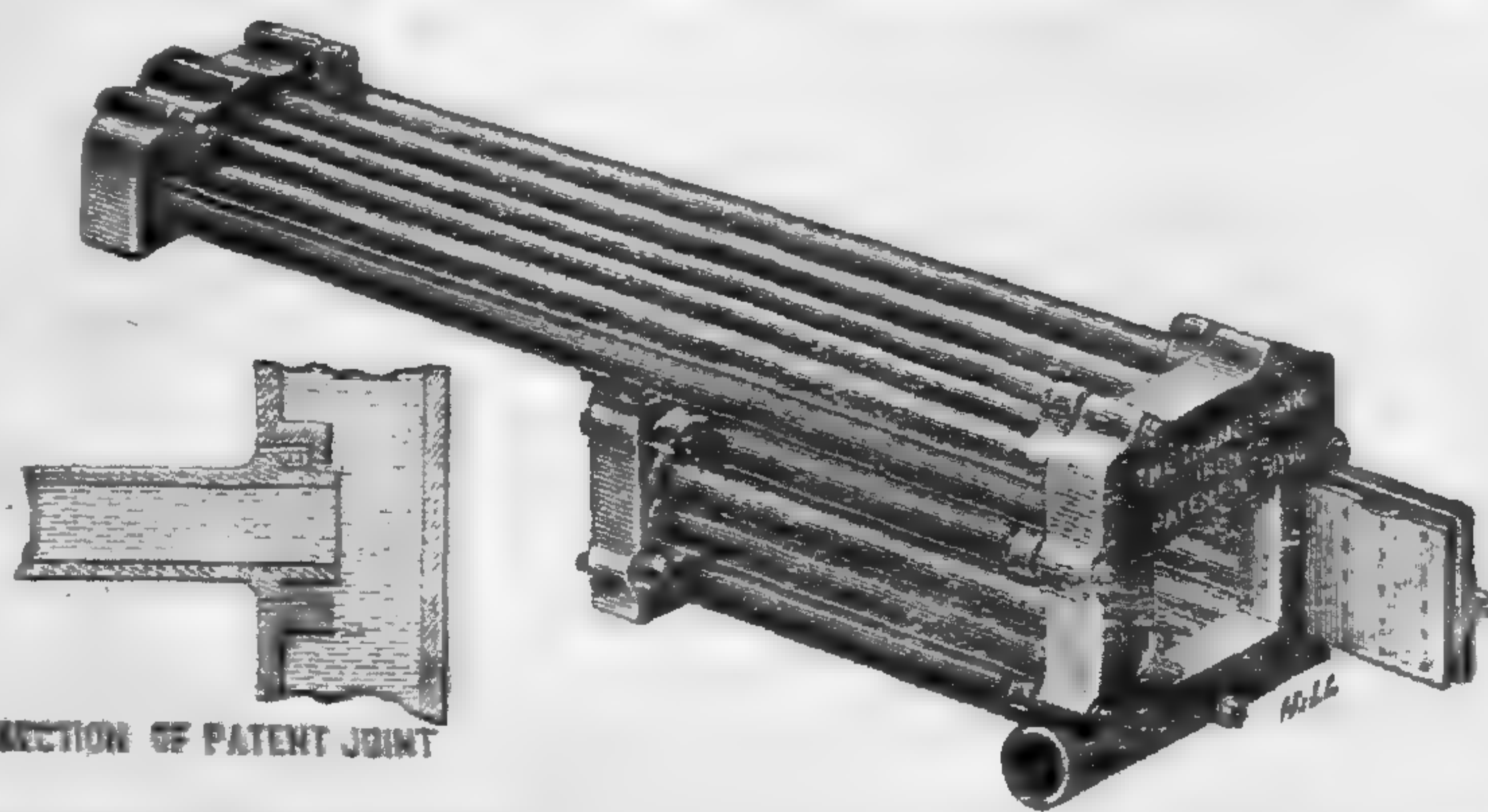

SECTION OF PATENT JOINT

It can be erected in a few hours, and may be relied upon as a thoroughly sound and good Hot-water Generator. It has been carefully tested in every possible way, more especially with regard to power and durability, and the result has been highly satisfactory.

In the event of a Pipe requiring to be replaced, we have perfected an arrangement whereby same may be effected in the course of a FEW MINUTES, without the necessity of disturbing the brickwork setting.

THE LARGEST AND MOST COMPLETE STOCK OF
HOT-WATER BOILERS OF EVERY DESCRIPTION,
PIPES, CONNECTIONS, VALVES, VENTILATING GEAR, &c.

INSPECTION INVITED.

PRICE LIST ON APPLICATION.

ILLUSTRATED CATALOGUE, 1s.

UPPER GROUND STREET, BLACKFRIARS, LONDON, S.E.

VOL. IX.—PART 107.

PRICE, 5s.

THE
ORCHID ALBUM,

COMPRISING

COLOURED FIGURES AND DESCRIPTIONS
OF
NEW, RARE, AND BEAUTIFUL
ORCHIDACEOUS PLANTS.

CONDUCTED BY

ROBERT WARNER, F.L.S., F.R.H.S.,
AUTHOR OF SELECT ORCHIDACEOUS PLANTS,

HENRY WILLIAMS, F.L.S., F.R.H.S.,

AND

WILLIAM HUGH GOWER, F.R.H.S.

THE COLOURED FIGURES BY JOHN NUGENT FITCH, F.L.S.

CONTENTS.

- PLATE 425. ODONTOGLOSSUM HASTILABIUM.
„ 426. CYPRIPIEDIUM PORPHYROCHLAMYS.
„ 427. ZYGOPETALUM MACKAYI.
„ 428. CYPRIPIEDIUM LOWII.

LONDON:

PUBLISHED BY B. S. WILLIAMS & SON,

AT THE

VICTORIA AND PARADISE NURSERIES, UPPER HOLLOWAY, N.

[All Rights Reserved.]

CASES FOR BINDING the Volumes of this Work can be supplied, PRICE 3s. 6d. EACH.
ALL BACK PARTS KEPT IN STOCK.

WORKS BY B. S. WILLIAMS, F.L.S., F.R.H.S.

"Mr. WILLIAMS has long been known as one of our best and most successful plant growers."—*Gardeners' Chronicle*.
 "Mr. WILLIAMS' skill as a plant cultivator is well and widely known."—*Journal of Horticulture*.

THE ORCHID-GROWERS' MANUAL

6th EDITION, ENLARGED AND REVISED.

BY

BENJAMIN SAMUEL WILLIAMS, F.L.S., F.R.H.S.,

Author of "The Orchid Album," "Select Ferns and Lycopods," "Choice Stove and Greenhouse Flowering Plants," "Choice Stove and Greenhouse Ornamental-leaved Plants," &c.

Post 8vo., Cloth, price 15s.; Free by Parcel Post, 15s. 6d.

PROFUSELY ILLUSTRATED WITH A LARGE NUMBER OF PAGE AND DOUBLE-PAGE ENGRAVINGS ON WOOD, TOGETHER WITH BLOCKS ILLUSTRATIVE OF TYPES OF THE VARIOUS GENERA.

The first edition of this work was published thirty-six years ago, and ever since its publication it has been considered to be the Orchid-Growers' Text Book, as is evinced by the numerous letters we are constantly receiving from all parts of the world, wherein our correspondents state that the "Orchid-Growers' Manual has been their only book of reference and constant friend in the cultivation of these plants.

This popular work has been entirely remodelled and revised up to the present time, and has been enlarged to 659 pages. It contains descriptions of upwards of 1470 species and varieties of Orchidaceous plants, together with 478 synonyms; also authorities for the names, the families to which the various genera belong, the flowering period, native country, and references to figures. In addition to this, chapters on the following subjects are given:—

Habitats of Tropical Orchids
 Season for Collecting Orchids
 Hints on Collecting Orchids
 Risks of Collecting Orchids
 Orchid Treatment during Growth
 Orchid Treatment during Rest
 Adaptation of Treatment to Surrounding Conditions
 Treatment of Newly-Imported Plants
 Treatment of Plants in Bloom

On Making Orchid Baskets
 Potting Epiphytal Orchids
 Potting Terrestrial Orchids
 Mode of Inducing back Growth
 Watering Orchids
 Propagation of Orchids
 Raising Orchids from Seeds
 Orchids for Room Decoration
 Construction of Orchid Houses
 Glazing of Orchid Houses

Heating of Orchid Houses
 Ventilation of Orchid Houses
 Shading of Orchid Houses
 Growing Specimen Orchids for Exhibition
 Treatment Preparatory to Exhibition
 Packing Orchids for Exhibitions
 Insects and other Enemies
 Diseases of Orchids
 Greenhouse and Frame Orchids.

Making in all the most complete work on Orchids ever published.

PUBLISHED BY B. S. WILLIAMS & SON,
 VICTORIA AND PARADISE NURSERIES, UPPER HOLLOWAY, LONDON, N.

WILLIAMS' ORCHID-GROWERS' SUNDRIES.

BEST SELECTED FIBROUS PEAT FOR ORCHIDS.

10s. 6d. per sack, 21s. and 42s. per crate.

FRESH SPHAGNUM MOSS FOR ORCHIDS.

3s. per bushel, 12s. per sack.

OCTAGONAL TEAK-WOOD ORCHID BASKETS.

These Baskets, which are in increasing demand among Orchid Growers, are well made with the best quality *Octagonal* Teak Rods, fastened with Copper Wire. They are ordinarily made square, but can be had in Cylindrical, Boat, or Raft shapes. They are elegant in appearance, strong, and durable.

Outside Measure of Basket.	With Copper Wire, Nails, and Suspenders. Per doz.—s. d.	Outside Measure of Basket.	With Copper Wire, Nails, and Suspenders. Per doz.—s. d.		Per inch run
3 inches	6 0	8 inches	16 0	Rafts	1d.
4 "	8 0	9 "	18 0	Boats	1½d.
5 "	10 0	10 "	21 0	Cylinders	2d.
6 "	12 0	11 "	23 0		
7 "	14 0	12 "	26 0		

Special Shapes and Sizes made to order.

WILLIAMS' ORCHID PANS.

These Pans are well adapted and highly recommended for growing Orchids in, suspended from the roof, and are a good substitute for wooden baskets and blocks. The Pans, as sold, have holes bored in the side for attaching the wires to.

Diameter.	Per doz.—s. d.	Diameter.	Per doz.—s. d.	Diameter.	Per doz.—s. d.
2 inches	1 0	3½ inches	1 9	6 inches	4 0
2½ "	1 3	4 "	2 3	7 "	5 0
3 "	1 6	5 "	3 0	8 "	6 0

B. S. WILLIAMS & SON,
 VICTORIA AND PARADISE NURSERIES,
 UPPER HOLLOWAY, LONDON, N.

WILLIAMS' HOTHOUSE SHADING,

THE MOST SUITABLE FOR

Shading Orchids, Ferns, Palms, & Stove & Greenhouse Plants.

IT is a strong, durable Cotton Netting, woven in squares so close as to exclude the direct rays of the sun, but admitting the greatest amount of light attainable through shading. It withstands the weather better than any other class of Shading, and may be beneficially used on account of the thickness of its texture, during cold weather, to keep the frost out. The leading Orchid and Plant Growers in the country have used this material for some years, and speak very highly of it, pronouncing it to be the very best material for Plants they have ever used.

BLINDS MADE UP AND FIXED COMPLETE IN ANY PART OF THE COUNTRY.

Sold in pieces 30 yds. long by 1½ yd. wide, price 40s. each. Samples submitted gratis.

WILLIAMS' NEW "EUREKA" SHADING.



REGISTERED.

A WANT has long been felt amongst plant cultivators for a good, cheap Shading which can be readily applied, where blinds are not used. This new material is introduced to supply this want. It is in the form of a white powder, and is prepared for use by applying boiling water to the compound, and allowing it to cool, when it can be applied by means of a brush. This new Shading is a great advantage over "Summer Cloud," and other preparations which have to be applied in a warm state—a most inconvenient method. In addition to this, it is of a white colour, which, being a non-conductor of heat, reflects the rays of the sun, thereby keeping the houses upon which it is used much cooler. It dries instantaneously, and can be rubbed off easily, when moist, without the use of soda, which is required where paint is used. It will last the whole season, and it is not necessary to wash it off, as it will disappear by degrees when the autumn rains come; this is a great point in its favour, as well as being the *CHEAPEST SHADING IN THE MARKET.*

☞ This Shading may be used not only upon Greenhouses but upon Skylights, Windows, or anywhere where glass is employed.

This Shading can be supplied in a GREEN POWDER if desired.

Sold in 1-lb. packets, with directions for use, price 1s. each.

1 lb. free by Parcel Post for 1s. 4½d., 2 lbs. free by Parcel Post for 2s. 6d.

— EACH PACKET WILL MAKE HALF-A-GALLON OF SHADING MATERIAL WHEN MIXED. —

— TESTIMONIALS —

From Mr. PENNY, Gardener to H.R.H. THE PRINCE OF WALES, Sandringham.

"I am so delighted with your preparation for Shading, called 'Eureka,' that I am induced this year to go in largely for it. Once put on it lasts the whole season, and the sun's rays are so subdued and no light obscured that plant life seems really to rally under its softening influence. I should think that when it is more known it will become quite the gardener's friend."

From Mr. BIRCH, Gardener to THE MARQUIS OF NORTHAMPTON, Castle Ashby.

"I am much pleased with the results of your 'Eureka' Shading; it is most useful, and so cheap. It is excellent for Ferneries, Palm Houses, and Conservatories."

From WILLIAM SMITH, Gardener to THE EARL OF STAIG, Oxenford.

"It answers the purpose of Shading our Camellias, Orchids, &c., so well that I cannot think of doing without it this summer, and it is so easily applied when mixed up, that we can apply it any day afterwards."

Manufactured and Sold by

B. S. WILLIAMS & SON,
VICTORIA AND PARADISE NURSERIES, UPPER HOLLOWAY, LONDON, N.

MR. J. C. STEVENS'

SALES BY AUCTION

OF

ESTABLISHED AND IMPORTED ORCHIDS

TAKE PLACE

EVERY WEEK AT HIS GREAT ROOMS,

38, KING STREET, COVENT GARDEN.

CATALOGUES FORWARDED ON RECEIPT OF TWO STAMPS.

SPECIAL NOTICE.—The price of the "Gardeners' Chronicle" is Threepence.

THE GARDENERS' CHRONICLE

("THE TIMES OF HORTICULTURE").

A Weekly Illustrated Journal

(ESTABLISHED 1841)

DEVOTED TO ALL BRANCHES OF GARDENING, FORESTRY, & RURAL PURSUITS.

EVERY FRIDAY, Price Threepence; Post Free to the Continent, Fourpence.

ALL SUBSCRIPTIONS PAYABLE IN ADVANCE.

THE UNITED KINGDOM: Twelve Months, 15s.; Six Months, 7s. 6d.; Three Months, 3s. 9d.; post free.

FOREIGN SUBSCRIPTIONS (excepting India and China): Including Postage, 17s. 6d. for Twelve Months. India and China, 19s. 6d.

P.O.O. to be made payable at The Post Office, 42, DRURY LANE, London, to A. G. MARTIN.

A. G. MARTIN, 41, WELLINGTON STREET, STRAND, LONDON.

MESSRS. PROTHEROE & MORRIS'S AUCTION SALES

ESTABLISHED & IMPORTED ORCHIDS

Take place Every Week at their

CENTRAL SALE ROOMS,

67 & 68, CHEAPSIDE, LONDON, E.C.

(Next door but one to Bennett's Clock).

CATALOGUES WILL BE FORWARDED ON APPLICATION.

CONTRACTORS TO HER MAJESTY'S WAR DEPARTMENT.

THE THAMES BANK IRON COMPANY,

(Telegraphic Address—"HOTWATER, LONDON." Telephone—No. 4,763.)

"CHAMPION" Horizontal Tubular Boiler (Patent)

THE BEST ALL-ROUND BOILER IN THE MARKET.

It combines all the advantages of its class so well known, and by the improved method of forming the joints, viz., with India Rubber Washers, the old and too often ineffectual way of caulking the joints is entirely dispensed with.

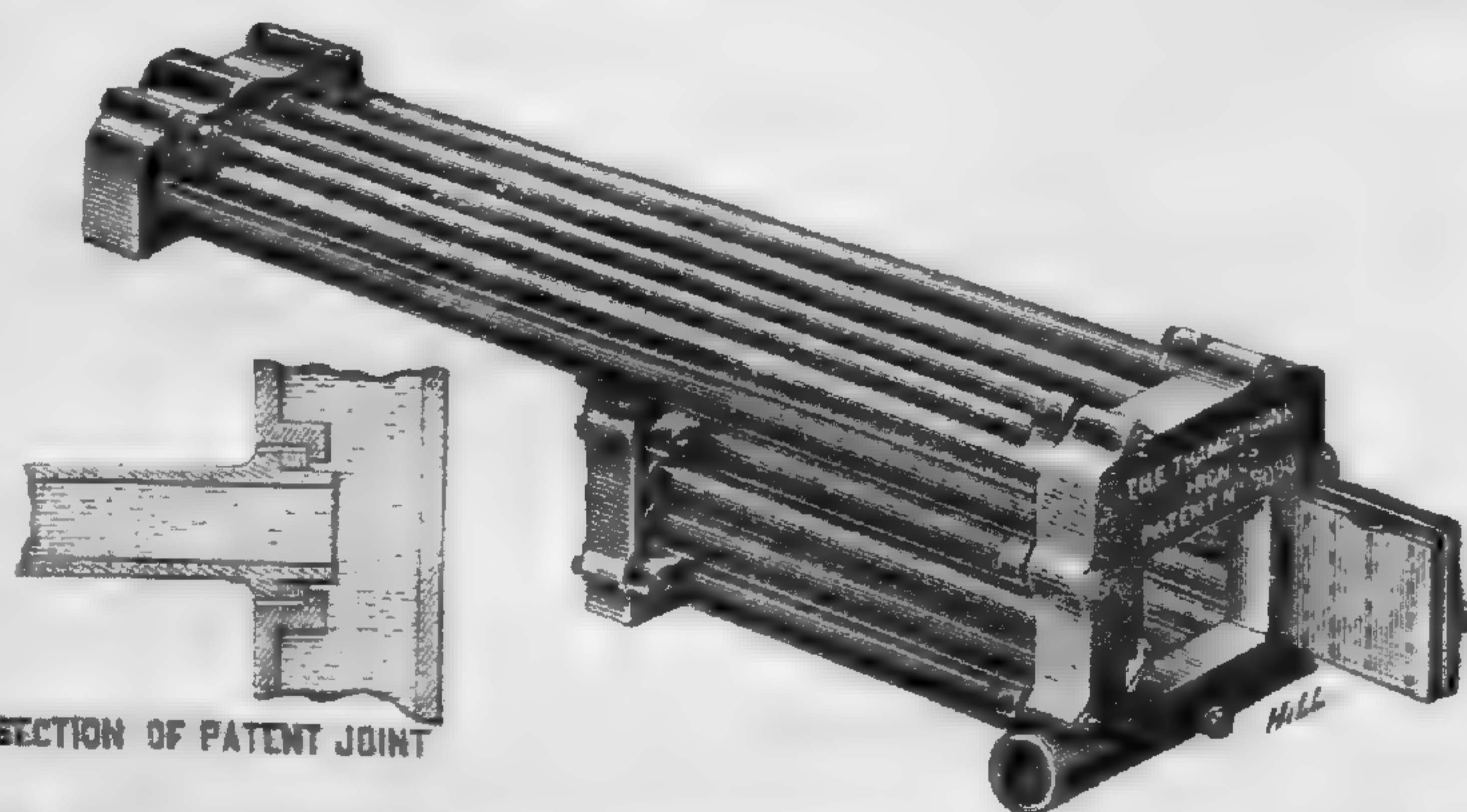

It can be erected in a few hours, and may be relied upon as a thoroughly sound and good Hot-water Generator. It has been carefully tested in every possible way, more especially with regard to power and durability, and the result has been highly satisfactory.

In the event of a Pipe requiring to be replaced, we have perfected an arrangement whereby same may be effected in the course of a FEW MINUTES, without the necessity of disturbing the brickwork setting.

THE LARGEST AND MOST COMPLETE STOCK OF
HOT-WATER BOILERS OF EVERY DESCRIPTION,
PIPES, CONNECTIONS, VALVES, VENTILATING GEAR, &c.

INSPECTION INVITED.

PRICE LIST ON APPLICATION.

ILLUSTRATED CATALOGUE, 1s.

UPPER GROUND STREET, BLACKFRIARS, LONDON, S.E.

VOL. IX.—PART 108.

PRICE, 5s.

THE
ORCHID ALBUM,

COMPRISING

COLOURED FIGURES AND DESCRIPTIONS
OF
NEW, RARE, AND BEAUTIFUL
ORCHIDACEOUS PLANTS.

CONDUCTED BY

ROBERT WARNER, F.L.S., F.R.H.S.,
AUTHOR OF SELECT ORCHIDACEOUS PLANTS,

HENRY WILLIAMS, F.L.S., F.R.H.S.,

AND

WILLIAM HUGH GOWER, F.R.H.S.

THE COLOURED FIGURES BY JOHN NUGENT FITCH, F.L.S.

CONTENTS.

- PLATE 429. ODONTOGLOSSUM MULUS HOLFORDIANUM.
" 430. CYMBIDIUM ELEGANS.
" 431. MASDEVALLIA MACRURA.
" 432. CATTLEYA DOWIANA AUREA (YOUNG'S VAR.)

LONDON:

PUBLISHED BY B. S. WILLIAMS & SON,

AT THE

VICTORIA AND PARADISE NURSERIES, UPPER HOLLOWAY, N.

[All Rights Reserved.]

WORKS BY B. S. WILLIAMS, F.L.S., F.R.H.S.

"Mr. WILLIAMS has long been known as one of our best and most successful plant growers."—*Gardeners' Chronicle*.
"Mr. WILLIAMS' skill as a plant cultivator is well and widely known."—*Journal of Horticulture*.

THE ORCHID-GROWERS' MANUAL

6th EDITION, ENLARGED AND REVISED.

BY

BENJAMIN SAMUEL WILLIAMS, F.L.S., F.R.H.S.,

Author of "The Orchid Album," "Select Ferns and Lycopods," "Choice Stove and Greenhouse Flowering Plants," "Choice Stove and Greenhouse Ornamental-leaved Plants," &c.

Post 8vo., Cloth, price 15s.; Free by Parcel Post, 15s. 6d.

PROFUSELY ILLUSTRATED WITH A LARGE NUMBER OF PAGE AND DOUBLE-PAGE ENGRAVINGS ON WOOD, TOGETHER WITH BLOCKS ILLUSTRATIVE OF TYPES OF THE VARIOUS GENERA.

The first edition of this work was published thirty-six years ago, and ever since its publication it has been considered to be the Orchid-Growers' Text Book, as is evinced by the numerous letters we are constantly receiving from all parts of the world, wherein our correspondents state that the "Orchid-Growers' Manual has been their only book of reference and constant friend in the cultivation of these plants.

This popular work has been entirely remodelled and revised up to the present time, and has been enlarged to 659 pages. It contains descriptions of upwards of 1470 species and varieties of Orchidaceous plants, together with 478 synonyms; also authorities for the names, the families to which the various genera belong, the flowering period, native country, and references to figures. In addition to this, chapters on the following subjects are given:—

Habitats of Tropical Orchids
Season for Collecting Orchids
Hints on Collecting Orchids
Risks of Collecting Orchids
Orchid Treatment during Growth
Orchid Treatment during Rest
Adaptation of Treatment to Surrounding Conditions
Treatment of Newly-Imported Plants
Treatment of Plants in Bloom

On Making Orchid Baskets
Potting Epiphytal Orchids
Potting Terrestrial Orchids
Mode of Inducing back Growth
Watering Orchids
Propagation of Orchids
Raising Orchids from Seeds
Orchids for Room Decoration
Construction of Orchid Houses
Glazing of Orchid Houses

Heating of Orchid Houses
Ventilation of Orchid Houses
Shading of Orchid Houses
Growing Specimen Orchids for Exhibition
Treatment Preparatory to Exhibition
Packing Orchids for Exhibitions
Insects and other Enemies
Diseases of Orchids
Greenhouse and Frame Orchids.

Making in all the most complete work on Orchids ever published.

PUBLISHED BY B. S. WILLIAMS & SON,
VICTORIA AND PARADISE NURSERIES, UPPER HOLLOWAY, LONDON, N.



For destroying Weeds on Garden Walks, Carriage Drives, Roads, Stable Yards, &c., also for Killing Plantain on Lawns. Saves more than twice its cost in Labour. No Smell. Does not stain the Gravel.

ONE APPLICATION WILL KEEP THE WALKS CLEAR OF WEEDS FOR AT LEAST EIGHTEEN MONTHS.

MR. W. G. HEAD, Superintendent, Crystal Palace Gardens, writes:—"We were so satisfied with your composition and its price, that we have used it absolutely, and have every confidence in recommending it."

MR. J. BELL, the Duke of Wellington's Gardener, says:—"Your Weed Killer will prove to be a great boon. It not only destroys every form of Weed, but leaves the gravel bright and clean."

The Empress Eugénie's Gardener, MR. E. S. McLAURIN, writes:—"The Weed Killer has proved so satisfactory that I purpose using much more of it next year."

Used in the proportion of one gallon to twenty-five gallons of water. The solution is applied with an ordinary watering can.

Prices: In 1 and 2-gal. Tins, 2s. per gal. (Tin included); in 5-gal. Drums, 1s. 6d. per gal.; in 10 and 15-gal. Drums, 1s. 4d. per gallon.

Special quotations for larger quantities. Carriage paid on 10 gallons and upwards.

Highly Commended by the Judges at the Alexandra Palace Rose Show, 1889, after fifteen months' trial.

Awarded a Certificate of Merit by the Scottish Horticultural Association, 1889.

ANTI-FUNGI POWDER, THE ONLY EFFECTUAL REMEDY FOR TOMATO DISEASE, MOULD AND MILDEW ON ROSES, VINES, &c.

It can be applied with an ordinary Powder Distributor, has no smell, and is harmless to the plants and fruit.

MR. W. HILLS, Gardener to Viscount Gort, East Cowes Castle, writes:—"I have used your Anti-Fungi Powder on Tomatos badly diseased, and found it at once stopped its progress. It is a great boon to Tomato growers."

MR. W. CHILD, Gardener to the Rev. W. Wilks, Secretary to the Royal Horticultural Society, says:—"I have found it to be very good, and entirely dispels all traces of Mildew on Chrysanthemums and other plants."

MR. CHARLES ROSS, Welford Park Gardens, Newbury, writes:—"The Powder answered for checking the disease on the Tomato leaves."

Prices: 1 lb., 1s.; 3 lbs., 2s. 9d.; 7 lbs., 5s. 6d.; 14 lbs., 10s.; 28 lbs., 18s.; 56 lbs., 35s. Carriage paid on 28 lbs. and upwards.

SOLE PROPRIETORS AND MANUFACTURERS:

THE AGRI-HORTICULTURAL CHEMICAL COMPANY, TUNBRIDGE, KENT; and CARLTON STREET, BOLTON, LANCASHIRE.

Principal Agents in London:—Messrs. CORRY, SOPER, FOWLER, & Co., Limited, Finsbury Street; BARR & SONS, King Street, Covent Garden; and HOOPER & Co., Limited, Covent Garden.

Agents in Ireland:—Messrs. W. DRUMMOND & SONS, 58, Dawson Street, Dublin; W. CARSON & SONS, 21, Bachelor's Walk, Dublin; ALEX. DICKSON & SONS, 55, Royal Avenue, Belfast; and MCKENZIE & SONS, Limited, Camden Quay, Cork.

WILLIAMS' HOTHOUSE SHADING,

THE MOST SUITABLE FOR

Shading Orchids, Ferns, Palms, & Stove & Greenhouse Plants.

It is a strong, durable Cotton Netting, woven in squares so close as to exclude the direct rays of the sun, but admitting the greatest amount of light attainable through shading. It withstands the weather better than any other class of Shading, and may be beneficially used on account of the thickness of its texture, during cold weather, to keep the frost out. The leading Orchid and Plant Growers in the country have used this material for some years, and speak very highly of it, pronouncing it to be the very best material for Plants they have ever used.

BLINDS MADE UP AND FIXED COMPLETE IN ANY PART OF THE COUNTRY.

Sold in pieces 30 yds. long by 1½ yd. wide, price 40s. each. Samples submitted gratis.

WILLIAMS' NEW "EUREKA" SHADING.



REGISTERED.

A WANT has long been felt amongst plant cultivators for a good, cheap Shading which can be readily applied, where blinds are not used. This new material is introduced to supply this want. It is in the form of a white powder, and is prepared for use by applying boiling water to the compound, and allowing it to cool, when it can be applied by means of a brush. This new Shading is a great advantage over "Summer Cloud," and other preparations which have to be applied in a warm state—a most inconvenient method. In addition to this, it is of a white colour, which, being a non-conductor of heat, reflects the rays of the sun, thereby keeping the houses upon which it is used much cooler. It dries instantaneously, and can be rubbed off easily, when moist, without the use of soda, which is required where paint is used. It will last the whole season, and it is not necessary to wash it off, as it will disappear by degrees when the autumn rains come; this is a great point in its favour, as well as being the *CHEAPEST SHADING IN THE MARKET.*

This Shading may be used not only upon Greenhouses but upon Skylights, Windows, or anywhere where glass is employed.

This Shading can be supplied in a GREEN POWDER if desired.

Sold in 1-lb. packets, with directions for use, price 1s. each.

1 lb. free by Parcel Post for 1s. 4½d., 2 lbs. free by Parcel Post for 2s. 6d.

EACH PACKET WILL MAKE HALF-A-GALLON OF SHADING MATERIAL WHEN MIXED.

TESTIMONIALS

From Mr. PENNY, Gardener to H.R.H. THE PRINCE OF WALES, Sandringham.

"I am so delighted with your preparation for Shading, called 'Eureka,' that I am induced this year to go in largely for it. Once put on it lasts the whole season, and the sun's rays are so subdued and no light obscured that plant life seems really to rally under its softening influence. I should think that when it is more known it will become quite the gardener's friend."

From Mr. BIRCH, Gardener to THE MARQUIS OF NORTHAMPTON, Castle Ashby.

"I am much pleased with the results of your 'Eureka' Shading; it is most useful, and so cheap. It is excellent for Ferneries, Palm Houses, and Conservatories."

From WILLIAM SMITH, Gardener to THE EARL OF STAIR, Oxenford.

"It answers the purpose of Shading our Camellias, Orchids, &c., so well that I cannot think of doing without it this summer, and it is so easily applied when mixed up, that we can apply it any day afterwards."

Manufactured and Sold by

B. S. WILLIAMS & SON,
VICTORIA AND PARADISE NURSERIES, UPPER HOLLOWAY, LONDON, N.

MR. J. C. STEVENS'

SALES BY AUCTION

OF

ESTABLISHED AND IMPORTED ORCHIDS

TAKE PLACE

EVERY WEEK AT HIS GREAT ROOMS,

38, KING STREET, COVENT GARDEN.

CATALOGUES FORWARDED ON RECEIPT OF TWO STAMPS.

SPECIAL NOTICE.—The price of the "Gardeners' Chronicle" is Threepence.

THE GARDENERS' CHRONICLE

("THE TIMES OF HORTICULTURE").

A Weekly Illustrated Journal

(ESTABLISHED 1841)

DEVOTED TO ALL BRANCHES OF GARDENING, FORESTRY, & RURAL PURSUITS.

EVERY FRIDAY, Price Threepence; Post Free to the Continent, Fourpence.

ALL SUBSCRIPTIONS PAYABLE IN ADVANCE.

THE UNITED KINGDOM: Twelve Months, 15s.; Six Months, 7s. 6d.; Three Months, 3s. 9d.; post free.

FOREIGN SUBSCRIPTIONS (excepting India and China): Including Postage, 17s. 6d. for Twelve Months. India and China, 19s. 6d.

P.O.O. to be made payable at The Post Office, 42, DRURY LANE, London, to A. G. MARTIN.

A. G. MARTIN, 41, WELLINGTON STREET, STRAND, LONDON.

MESSRS. PROTHEROE & MORRIS'S AUCTION SALES

ESTABLISHED & IMPORTED ORCHIDS

Take place Every Week at their

CENTRAL SALE ROOMS,
67 & 68, CHEAPSIDE, LONDON, E.C.

(Next door but one to Bennett's Clock).

CATALOGUES WILL BE FORWARDED ON APPLICATION.

CONTRACTORS TO HER MAJESTY'S WAR DEPARTMENT.

THE THAMES BANK IRON COMPANY,

(Telegraphic Address—"HOTWATER, LONDON." Telephone—No. 4,763.)

"CHAMPION" Horizontal Tubular Boiler (Patent)

THE BEST ALL-ROUND BOILER IN THE MARKET.

It combines all the advantages of its class so well known, and by the improved method of forming the joints, viz., with India Rubber Washers, the old and too often ineffectual way of caulking the joints is entirely dispensed with.

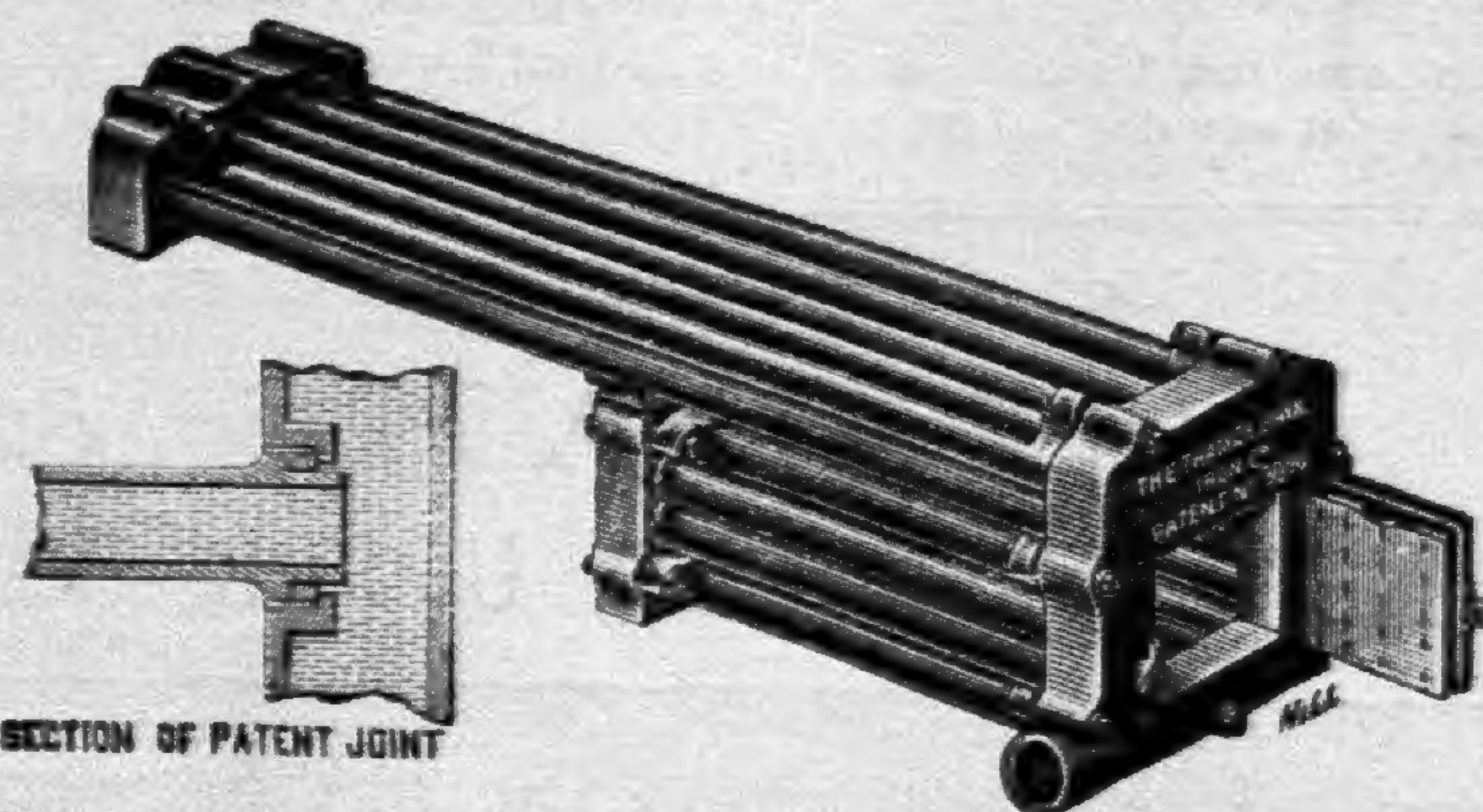

SECTION OF PATENT JOINT

It can be erected in a few hours, and may be relied upon as a thoroughly sound and good Hot-water Generator. It has been carefully tested in every possible way, more especially with regard to power and durability, and the result has been highly satisfactory.

In the event of a Pipe requiring to be replaced, we have perfected an arrangement whereby same may be effected in the course of a FEW MINUTES, without the necessity of disturbing the brickwork setting.

THE LARGEST AND MOST COMPLETE STOCK OF
HOT-WATER BOILERS OF EVERY DESCRIPTION,
PIPES, CONNECTIONS, VALVES, VENTILATING GEAR, &c.

INSPECTION INVITED.

PRICE LIST ON APPLICATION.

ILLUSTRATED CATALOGUE, 1s.

UPPER GROUND STREET, BLACKFRIARS, LONDON, S.E.